



NATIONAL BUILDING CODE OF CANADA ENGINEERING EVALUATION REPORT

Date	2022-12-31
Report Number	0078-1-5-5873
Client Name	Trex Company, Inc.
Address	160 Exeter Dr., Winchester, VA 22603-8605

Subject

Trex Signature® Railing Systems: Aluminum Railing, 8' Rod Rail, 6' Rod Rail, Glass Railing

Evaluation Scope

This report is provided to assist registered design professionals and building officials in Canada with determining compliance to the performance objectives in the named building codes.

The material(s) and system(s) described herein have been evaluated to the 2015 National Building Code of Canada (NBCC), Division A, Section 1.2.1.1.(1)(a) for compliance with the applicable acceptable solutions in Division B, for buildings classified under Part 3/4/5 and Part 9 construction.

CSI DIVISION: 05 00 00 METALS
SUBDIVISION: 05 52 00 Metal Railings

CODE SECTIONS AND STANDARDS:

NBCC Div. B Section	Description	Referenced Standard or Div. B Section ¹	Year
3.3.1.18	All Floor Areas, Guards	3.3.4.7, 3.3.5.10	-
3.3.2.9	Assembly Occupancy, Guards	-	-
3.3.4.7	Residential Occupancy, Stairs, Ramps, Landings, Handrails and Guards for Dwelling Units	9.8	-
3.3.5.10	Industrial Occupancy, Guards	-	-
3.4.6.6	Types of Exit Facilities, Guards	3.3.4.7, 3.3.5.10	-
4.1.1.5.(1)	Structural Loads and Procedures, Design Basis	-	-
4.1.3.2.(2)	Limit States Design, Strength and Stability	Table 4.1.3.2.-A	-
4.1.3.4	Limit States Design, Serviceability	4.1.3.5	-
4.1.3.5	Limit States Design, Deflection	-	-
4.1.5.14	Loads on Guards and Handrails	-	-
4.1.7	Wind Load	-	-
4.3.5.1	Design Basis for Aluminum	CSA S157	2005
4.3.6.1	Design Basis for Glass	CGSB 12.20-M	1989
9.4.1.1.(1)(c)(i)	Structural Design Requirements and Application Limits	Part 4	-
9.8.8.2	Loads on Guards	Table 9.8.8.2	-



9.8.8.3	Height of Guards	-	-
9.8.8.5	Openings in Guards	-	-
9.8.8.6	Design of Guards to Not Facilitate Climbing	-	-
9.8.8.7	Glass in Guards	CGSB 12.1-M	1990

1. Only the applicable reference standards and code sections cited in the main body text are listed. (-) indicates that the main body text covers the full explanation of the objective.

Table 1: OCCUPANCY CLASSIFICATION CONFORMANCE

System Description	2015 NBCC Div. B Sections					
	3.3.1.18	3.3.2.9	3.3.4.7	3.3.5.10	9.8	9.8
	All floor areas ¹	Group A Assembly	Group C Residential	Group F Industrial	Part 9 Housing & Small Buildings, All guards	Part 9 Housing & Small Buildings, Max 2 dwelling
Aluminum Railing	No	No	Yes	Yes	Yes	Yes
8' Rod Rail	No	No	No	Yes	No	No
6' Rod Rail	No	No	No	Yes	No	No
Glass Railing	Yes ²	Yes ²	Yes	Yes	Yes	Yes

1. All floor areas loading covers those occupancies listed in this table which also have specific sub-sections for guards, as well as Group B Detention, Treatment, Care, Group D Business, Group E Mercantile.

2. Does not include open viewing stands without fixed seats or paths of egress in grandstands, stadia, bleachers and arenas.

Compliance Statement:

It is the opinion of Boca Engineering Co. that Trex Signature® Railing, when installed as described in this report, has demonstrated compliance with the objectives and functional statements of the listed sections of the 2015 National Building Code of Canada. Design and performance information can be found in the Product Evaluation section of this report.

This report has been prepared and reviewed on behalf of Boca Engineering Co. by:

Christopher Bowness, P.Eng., P.E.

2022-12-31

Date



PRODUCT EVALUATION _____ Pg. 3 – 7

ATTACHMENTS:

- 1. Components Specifications _____ Pg. 8
- 2. Allowable Post Spacing Tables _____ Pg. 9 – 12
- 3. Assembly and Component Drawings _____ Pg. 13 – 21
- 4. Discussion of Limit States Design Procedure _____ Pg. 22

EVALUATION REPORT TERMS:

- 1. This report is a general evaluation of the building code section requirements as identified and applies only to the samples that were evaluated. It does not imply any endorsement or warranty, nor that the signatory Engineer is the Designer of Record of any construction project for which the information is used.
- 2. This Evaluation Report expires Dec. 31, 2023, open to renewal. Up to the renewal date, the report is valid until such time as the named product(s) changes, the Quality Assurance Agency changes, or provisions of the Code that relate to the product change.



Product Evaluation

1.0 PRODUCT DESCRIPTION:

Trex Signature® Railing is a guardrail system comprised of aluminum rails and posts, aluminum picket or rod balusters or solid glass in-fill panels, and zinc brackets. Posts are optionally installed with wood-plastic composite post sleeves.

System Description	Post Configuration	No. of Footblocks	Span Between Posts	Guardrail Height
Aluminum Railing	Standard or Post Mount	1 [†]	Up to 96 in (2438 mm) Load-case Specific	42 in (1067 mm)
8' Rod Rail	Standard or Post Mount	1 [†]	Up to 96 in (2438 mm) Load-case Specific	42 in (1067 mm)
6' Rod Rail	Standard or Post Mount	1 [†]	Up to 72 in (1829 mm) Load-case Specific	42 in (1067 mm)
Glass Railing	Standard or Post Mount	1 [†]	Up to 72 in (1829 mm) Load-case Specific	42 in (1067 mm)

[†] Footblocks are positioned at the midspan of the bottom rail.

In the standard configuration, the railing assembly is installed between two aluminum posts, with the top and bottom rail brackets fastened directly to the posts.

In the post mount configuration, the railing assembly is installed between two aluminum posts concealed by wood-plastic composite post sleeves, which slide over two post mount spacers fastened to the top and bottom of each post. In this configuration, the top and bottom rail brackets are fastened to the post mount spacers through the post sleeves.

Posts are welded to an aluminum baseplate with pilot holes ready to attach to the substructure. See the attachments section at the end of this report for loading-case specific allowable post spacings, component specifications, connection details, component diagrams, and assembly drawings.

1.1 MATERIALS PROPERTIES:

The structural components of the guard system comply with the materials specifications within:

Aluminum Components: CSA S157-05, *Strength Design in Aluminum*.

Steel Fasteners: CSA S16-14, *Design of Steel Structures*.

Glass Panels: CGSB 12.20-M89, *Structural Design of Glass for Buildings*. (Materials supplied by others)

2.0 INSTALLATION:

1. Trex Signature® Railing aluminum components with fasteners are supplied as a package.* Components are manufactured to size, ready for assembly at the jobsite. Post baseplates are prepared ready with bolt holes for surface mounting to a code-compliant framing sub-structure by methods specific to the building project design. Attachment to sub-structure method is not covered in this design evaluation.
*Glass panels for the Glass Railing system are not supplied by Trex and are sourced at the jobsite.
2. Manufacturer's published installation instructions are available online at:
<https://www.trex.com/trex-owners/customer-support/downloads/#productinstall>.
3. Manufacture's installation instructions, building code, and additional details in this report are to be followed.



3.0 CODE SECTIONS REVIEW:

NBCC Div. B
Section

Description

3.3.1.18

All Floor Areas, Guards

Trex Signature® Railing conforms to the dimensional and functional requirements, and the structural loading requirements, for the floor area occupancy classifications shown in Table 1 of this report.

Aluminum Picket and Glass In-Fill Systems

There are no intermediate horizontal components within the infill and the system does not facilitate climbing, for where article 3.3.1.18.(4) applies when guards are protecting a level located more than one storey or 4.2 m above the adjacent level.

Rod Rail In-Fill Systems

The configuration of the rod in-fill may facilitate climbing, for where article 3.3.1.18.(4) applies Rod Rail guards must be limited to protecting a level located no more than one storey or 4.2 m above the adjacent level.

3.3.2.9

Assembly Occupancy, Guards

Trex Signature® Glass Railing conforms to the dimensional, functional and structural loading requirements of this Code section for some uses within this occupancy classification, see Table 1 of this report. *Aluminum Railing and Rod Railing do not apply in this occupancy.

3.3.4.7

Residential Occupancy, Stairs, Ramps, Landings, Handrails and Guards for Dwelling Units

The requirement is for Part 3 residential occupancy guards to conform to the requirements of Section 9.8. See this report commentary to article 9.8.

3.3.5.10

Industrial Occupancy, Guards

Trex Signature® Railing conforms to the dimensional, functional and structural loading requirements of this Code section.

3.4.6.6

Types of Exit Facilities, Guards

Trex Signature® Railing conforms to the dimensional, functional and structural loading requirements of this Code section for the occupancy classifications in Table 1 of this report.

4.1.1.5.(1)

Structural Loads and Procedures, Design Basis

The structural components in this guard system have been evaluated in accordance with materials design standards referenced within Part 4.

4.1.3.2.(2)

Limit States Design, Strength and Stability

Limit states load combinations of Table 4.1.3.2-A have been considered in this design evaluation. Section F.24 of User's Guide – NBC 2015, Structural Commentaries directs that guards are to be designed with load combinations for ultimate limit states.

Design load combinations used in this evaluation are:

Ultimate (ULS): $1.5L + 0.4W$, and, $1.4W + 0.5L$

Service (SLS): $1.0L + (0.75)0.4W$, and, $0.75W + 0.5L$



4.1.3.4 Limit States Design, Serviceability

Fatigue, deflection, and temperature and moisture effects serviceability limits states have been considered in the design analysis.

4.1.3.5 Limit States Design, Deflection

The deflection limits have been determined in accordance with ASTM E985-00(2006), *Standard Specification of Permanent Metal Railing Systems and Rails for Buildings*, which is recommended for use in Section F.23 of User’s Guide – NBC 2015, Structural Commentaries Part 4 of Division B. For systems with glass panels, further deflection criteria within CGSB 12.20-M89 is imposed on the glass components only.

4.1.5.14 Loads on Guards and Handrails

Sub-section	Load Type ¹	Design Service-Level Live Load	Deflection Limit 8-ft post spacing	Deflection Limit 6-ft post spacing
4.1.5.14.(3)	Infill Lower Center	0.5 kN (112 lb), over 100 mm ²	-	- ²
4.1.5.14.(3)	Infill Middle Center	0.5 kN (112 lb), over 100 mm ²	-	- ²
4.1.5.14.(1)(c)	Horizontal Uniform Load on Top Rail	0.75 kN/m (52 lb/ft)	70 mm (2.75 in)	64 mm (2.5 in) ²
4.1.5.14.(6)	Vertical Uniform Load on Top Rail	1.5 kN/m (102.7 lb/ft)	25 mm (1 in)	19 mm (0.75 in)
4.1.5.14.(1)(c)	Concentrated Load at Midspan of Top Rail (horiz)	1.0 kN (224 lb)	70 mm (2.75 in)	64 mm (2.5 in) ²
4.1.5.14.(1)(c)	Concentrated Load at Top Rail Adjacent to Post (horiz)	1.0 kN (224 lb)	-	-
4.1.5.14.(1)(c)	Concentrated Load at Top of Single Post (horiz)	1.0 kN (224 lb)	89 mm (3.5 in)	89 mm (3.5 in) ²

1. Article 4.1.5.14 states that these forces need not be considered to act simultaneously.
2. For glass panel systems only, the deflection limit is 40 mm (1.5 in) for each of these load placements.

The structural design analysis has been carried out in accordance with CSA S157-05 and ASTM E935-13, and CGSB 12.20-M89 where applicable. An expanded discussion of the design procedure is provided in Attachment 4.

The deflection limits measured at service level loads are found not to exceed the deflection limits determined in accordance with article 4.1.3.5 shown in Table 2 of this report.

The system is able to resist an ultimate load of 2.25 times the service level live load for each loading type shown in Table 2 of this report. Following CSA S157-05 Section 13.3.1.2, the 2.25 test load factor equates to the live load factor divided by the effective resistance factor.

The rail system shape geometry and strength are the same in the inward and outward direction, satisfying the loading criteria of article 4.1.5.14.(2).

The loading criteria of article 4.1.5.14.(4) does not apply for the Class C, F and Part 9 occupancy classifications cited in Table 1 of this report.

The reaction at the guard post base imparted to the building’s main structure from the maximum loading scenario is provided in the post spacing tables in Attachment 2. The site-specific base attachment must be designed to transfer this moment to the structure.

4.1.7 Wind Load

Wind load has been applied in the design model with applicable factors as per article 4.1.7.1.(5)(a), Static Procedure for secondary structural members.



- 4.3.5.1 Design Basis for Aluminum**
The design analysis has been carried out in accordance with and complies with CSA S157-05, *Strength Design in Aluminum*.
- 4.3.6.1 Design Basis for Glass**
The design analysis of glass components has been carried out in accordance with and complies with CGSB 12.20-M89, *Structural Design of Glass for Buildings*.
- 9.4.1.1.(1)(c)(i) Structural Design Requirements and Application Limits**
The design methodology in this evaluation for determining conformance to Part 9 has been performed in accordance with article 9.4.1.1.(1)(c)(i) using the loads and deflection limits specified in Part 9.
- 9.8.8.2 Loads on Guards**
Trex Signature® Railing is designed to resist the minimum specified loads for all of the guard types listed in Table 9.8.8.2, as detailed in Table 1 of this report.
- 9.8.8.3 Height of Guards**
The top rail height of Trex Signature® Railing is nominally 1070 mm (42 inches).
- 9.8.8.5 Openings in Guards**
The openings between the intermediate infill members and between the bottom rail and deck surface of Trex Signature® Railing does not exceed 100 mm (4 inches).
- 9.8.8.6 Design of Guards to Not Facilitate Climbing**
Aluminum Picket and Glass In-Fill Systems
There are no intermediate horizontal components within the infill and the system does not facilitate climbing, for where article 9.8.8.6 applies when guards are protecting a level located more than one storey or 4.2 m above the adjacent level.
Rod Rail In-Fill Systems
The configuration of the rod in-fill may facilitate climbing, for where article 9.8.8.6 applies Rod Rail guards must be limited to protecting a level located no more than one storey or 4.2 m above the adjacent level.
- 9.8.8.7 Glass in Guards**
Glass panels provided for in this design evaluation are tempered glass in conformance with CAN/CGSB-12.1-M, as recommended by Trex (supplied by others).
- 4.0 LIMITATIONS:**
1. This Evaluation is for the base code requirements of the building system as addressed in this report. In some building applications, additional performance objectives may be required by Code which must be addressed in the building design for those specific cases.
 2. Design calculations, drawings, and special inspections are to be furnished for building projects by registered professionals as required by the respective jurisdictional authorities and Codes.
 3. The design evaluation of Trex Signature® Railing is of the guard system components only, installed as described in this report. Attachment of the post baseplate to the main building structure has not been



detailed or evaluated within the scope of this evaluation. The post-base reaction forces (in units of moment) for design of those elements has been discussed in comments to article 4.1.5.14, and labeled on the system configuration drawing.

- Strength and performance values apply to temperature at deck surface ranging from -29°C to 52°C.

5.0 FIRE CLASSIFICATIONS:

Aluminum and glass components of the guard system are a *non-combustible* material as defined in NBCC Div A, 1.4.1.2.

Wood-plastic composite post sleeve components of the guard system are a *combustible* material as defined in NBCC Div A, 1.4.1.2.

Wood-plastic composite post sleeve components tested to CAN/ULC S102.2 have a Flame Spread Index of 40.

6.0 QUALITY ASSURANCE ENTITY:

The products evaluated in this report are surveyed at the approved manufacturing locations with third-party quality assurance inspections and product certification labeling by Intertek.

7.0 MANUFACTURING PLANTS:

The manufacturing plants of guard rail systems covered in this evaluation are located in the following city/state locations: Winchester, VA.

8.0 LABELING:

Labeling shall be in accordance with the requirements of and bear the certification mark of the Accredited Quality Assurance Agency.

9.0 REFERENCE TESTING AND EVALUATION DOCUMENTS:

Entity	Entity Accreditation ¹	Standards	Report No.	Issue Date
Intertek	IAS TL 274	ASTM E935-13	104848525COQ-001	2022-03-08
Trex	Footnote 2	ASTM E935-13	190301-BA-1	2019-07-19
Intertek	IAS TL 144	ASTM E935-13	i1676.01-119-19-R0 ³	2019-07-16
Right Testing Labs	IAS TL 859	CAN/ULC S102.2-18	RTL0028-1	2020-03-27
Intertek	IAS AA-647	Quality Assurance	Spec ID: 33509	2022-12-31

- Testing, certification, evaluation, and inspection agencies referenced have been verified to be accredited by Standards Council of Canada (www.scc.ca) or International Accreditation Service (www.iasonline.org) for the applicable scope, in good standing on the date of the evaluation, in accordance with ISO 17025 and ISO 17020 international standards for testing and inspection bodies.
- Testing performed at manufacturer’s R & D test facility witnessed by Boca Engineering Co.
- Ultimate strength test of post, verified procedure is in accordance with ASTM E935-13.

CERTIFICATION OF INDEPENDENCE:

- Boca Engineering Co., it’s employees and shareholders, do not have, nor do they intend to or will acquire, a financial interest in any company manufacturing or distributing products that they evaluate.
- Boca Engineering Co. is not owned, operated or controlled by any company manufacturing or distributing products that they evaluate.



ATTACHMENTS 1, 2 & 3: COMPONENTS SPECIFICATIONS, ALLOWABLE POST SPACING TABLES, ASSEMBLY DRAWINGS AND COMPONENTS DRAWINGS

TABLE 3: TREX SIGNATURE® RAILING, COMPONENTS SPECIFICATIONS

Component	Description
Top rail (two pieces) <i>Aluminum Railing and Rod Rail Systems</i>	1.565"-wide × 1.296"-high × 95.5"-long, "U"-shaped, extruded aluminum (6105-T5) channel with 1.74"-wide × 0.363"-high, rounded, extruded aluminum (6063-T6) snap-on cap (overall dimensions: 1.74" wide × 1.45" high)
Top rail <i>Glass Rail Systems</i>	1.74"-wide × 1.452"-high × 73.5"-long, extruded aluminum (6063-T6)
Bottom rail (two pieces) <i>Aluminum Railing and Rod Rail Systems</i>	1.74"-wide × 1.162"-high × 95.5"-long, "U"-shaped, extruded aluminum (6063-T6) channel with 1.74"-wide × 0.3"-high, flat, extruded aluminum (6063-T6) snap-on cap (overall dimensions: 1.74" wide × 1.23" high)
Bottom rail <i>Glass Rail Systems</i>	1.74"-wide × 1.23"-high × 71.5"-long, extruded aluminum (6063-T6)
Balusters	0.75" square × 0.05"-thick (wall) × 39.485"-long, hollow, extruded aluminum (6063-T6) tube
Middle (pinned) baluster	0.76" square × 0.058"-thick (wall) × 37.313"-long, hollow, extruded aluminum (6063-T6) tube with two internal screw bosses running the entire length of the profile
Rods (horizontal)	0.525" diameter × 0.125"-thick (wall) × 88.5" or 64.5" long aluminum (6061-T6)
Rods (vertical)	1.25" × 1.00" 0.125"-thick (wall) × 37.31" long aluminum (6063-T6)
Glass	¼" (6 mm) Tempered Glass
Rail insert	0.884"-wide × 0.96"-high × 93"-long, "U"-shaped, extruded PVC channel
Rail Stiffener	1.25" × 0.125"-thick (wall) × 95.5" long aluminum (6063-T6)
Top rail bracket	Collar-style, die-cast zinc (ZAMAK 3) bracket
Bottom rail bracket	Collar-style, die-cast zinc (ZAMAK 3) bracket
Footblock	1.375" square × 0.125"-thick (wall) × 2"-long, hollow, extruded aluminum (6063-T52) tube
Post	2.5" square × 0.125"-thick (wall) × 42.5"-long, hollow, extruded aluminum (6063-T6) tube welded on all four sides (0.25" × 0.25" fillet weld) using Ø0.045" aluminum (ER5356) wire to 4" square × 0.5"-thick aluminum (6063-T6) baseplate with four Ø0.406" holes spaced 3.25" on center in the corners for anchors and one Ø0.406" hole in the center (overall length: 43")
Post mount spacer	3.63" square × 7"-long, hollow, extruded aluminum (6063-T6) tube with eight internal ribs (two per side) running the entire length of the profile
Post sleeve	4.45" square × 0.15"-thick (wall), hollow, extruded wood-plastic composite tube with 12 internal ribs (three per side) running the entire length of the profile

TABLE 4: TREX SIGNATURE® RAILING, FASTENER SPECIFICATIONS

Connection	Fastener(s)
Top rail to top rail bracket	(2) #10-16 × 5/8", #2 square drive, pan head, self-drilling, stainless steel screws
Bottom rail to bottom rail bracket	(1) #10-16 × 5/8", #2 square drive, pan head, self-drilling, stainless steel screw
Middle (pinned) baluster to top and bottom rails	(2) #8-15 × 1-1/4", #2 square drive, pan head, stainless steel screws thru slot in rails into screw bosses in baluster
<i>For standard configuration</i>	
Top rail bracket to post	(3) #10-16 × 5/8", #2 square drive, pan head, self-drilling, stainless steel screws
Bottom rail bracket to post	(2) #10-16 × 5/8", #2 square drive, pan head, self-drilling, stainless steel screws
<i>For post mount configuration</i>	
Post mount spacer to post	(1) #10-15 × 1", #2 square drive, flat head, self-drilling, stainless steel screw
Top rail bracket to post mount spacer (thru post sleeve)	(3) #8-15 × 1-1/4", #2 Phillips drive, pan head, stainless steel screws
Bottom rail bracket to post mount spacer (thru post sleeve)	(2) #8-15 × 1-1/4", #2 Phillips drive, pan head, stainless steel screws



Part 3 Buildings – Aluminum Railing In-Fill Systems Maximum Post Spacings									
Wind pressure p (non-factored) as determined by NBCC 4.1.7.3.	p (kPa)	Residential One-Two Dwellings				All Other Guards			
		Maximum Post Spacing (mm)		Ultimate Moment at Post-Base Connection (kN-m) ¹		Maximum Post Spacing (mm)		Ultimate Moment at Post-Base Connection (kN-m) ¹	
		2 Post Span	3+ Post Span	2 Post Span	3+ Post Span	2 Post Span	3+ Post Span	2 Post Span	3+ Post Span
		0.5	2438	2438	1.02	2.03	2438	1770	1.51
0.75	2438	2438	1.04	2.06	2438	1748	1.53	2.18	
1.00	2438	2438	1.06	2.09	2438	1727	1.55	2.18	
1.25	2438	2438	1.08	2.13	2438	1707	1.57	2.18	
1.50	2438	2438	1.10	2.16	2438	1687	1.59	2.18	
1.75	2438	2421	1.12	2.18	2438	1667	1.61	2.18	
2.00	2438	2383	1.14	2.18	2438	1648	1.63	2.18	
2.25	2438	2346	1.16	2.18	2438	1629	1.65	2.18	
2.50	2438	2310	1.18	2.18	2438	1610	1.67	2.18	
2.75	2438	2274	1.20	2.18	2438	1592	1.69	2.18	

Part 9 Buildings Max 3-storeys – Aluminum Railing In-Fill Systems Maximum Post Spacings									
q 1/50 (kPa)	p (kPa)	Residential One-Two Dwellings				All Other Guards			
		Maximum Post Spacing (mm)		Ultimate Moment at Post-Base Connection (kN-m) ¹		Maximum Post Spacing (mm)		Ultimate Moment at Post-Base Connection (kN-m) ¹	
		2 Post Span	3+ Post Span	2 Post Span	3+ Post Span	2 Post Span	3+ Post Span	2 Post Span	3+ Post Span
		Field zone, Rough terrain^{2,3,4}							
0.4	0.64	2438	2438	1.03	2.04	2438	1758	1.52	2.18
0.48	0.77	2438	2438	1.04	2.06	2438	1747	1.53	2.18
0.58	0.93	2438	2438	1.05	2.08	2438	1733	1.54	2.18
0.63	1.01	2438	2438	1.06	2.10	2438	1727	1.55	2.18
0.78	1.25	2438	2438	1.08	2.13	2438	1707	1.57	2.18
1.0	1.60	2438	2438	1.11	2.18	2438	1679	1.60	2.18
Corner zone, Rough terrain^{2,3,4}									
0.4	0.84	2438	2438	1.05	2.07	2438	1741	1.54	2.18
0.48	1.01	2438	2438	1.06	2.10	2438	1727	1.55	2.18
0.58	1.22	2438	2438	1.08	2.12	2438	1710	1.57	2.18
0.63	1.32	2438	2438	1.08	2.14	2438	1701	1.57	2.18
0.78	1.64	2438	2438	1.11	2.18	2438	1676	1.60	2.18
1.0	2.10	2438	2368	1.15	2.18	2438	1640	1.64	2.18
Field zone, Open terrain^{2,3,4}									
0.4	0.92	2438	2438	1.05	2.08	2438	1734	1.54	2.18
0.48	1.10	2438	2438	1.07	2.11	2438	1719	1.56	2.18
0.58	1.33	2438	2438	1.09	2.14	2438	1700	1.57	2.18
0.63	1.45	2438	2438	1.10	2.16	2438	1691	1.58	2.18
0.78	1.79	2438	2414	1.12	2.18	2438	1664	1.61	2.18
1.0	2.30	2438	2338	1.16	2.18	2438	1625	1.65	2.18
Corner zone, Open terrain^{2,3,4}									
0.4	1.2	2438	2438	1.07	2.12	2438	1711	1.56	2.18
0.48	1.44	2438	2438	1.09	2.16	2438	1692	1.58	2.18
0.58	1.74	2438	2422	1.12	2.18	2438	1668	1.61	2.18
0.63	1.89	2438	2399	1.13	2.18	2438	1656	1.62	2.18
0.78	2.34	2438	2333	1.17	2.18	2438	1622	1.66	2.18
1.0	3.00	2438	2240	1.22	2.18	2438	1574	1.71	2.18

1. Ultimate moment is the factored reaction imparted at the post base in to the structure by the design loads on the guard system.
2. Field zone is a location anywhere not defined as a corner zone.
3. Corner zone as defined by NBCC 4.1.7.5.(5) is within a distance equal to the larger of 0.1W and 0.1D from a building corner, where W and D are the building plan dimensions.
4. Rough and Open terrain are as defined in NBCC 4.1.7.3.(5).



Part 3 Buildings – 8’ Rod Rail In-Fill Systems Maximum Post Spacings									
Wind pressure p (non-factored) as determined by NBCC 4.1.7.3.	p (kPa)	Residential One-Two Dwellings				All Other Guards			
		Maximum Post Spacing (mm)		Ultimate Moment at Post-Base Connection (kN-m) ¹		Maximum Post Spacing (mm)		Ultimate Moment at Post-Base Connection (kN-m) ¹	
		2 Post Span	3+ Post Span	2 Post Span	3+ Post Span	2 Post Span	3+ Post Span	2 Post Span	3+ Post Span
		0.5	2438	2438	1.02	2.03	2438	1770	1.51
0.75	2438	2438	1.04	2.06	2438	1748	1.53	2.18	
1.00	2438	2438	1.06	2.09	2438	1727	1.55	2.18	
1.25	2438	2438	1.08	2.13	2438	1707	1.57	2.18	
1.50	2438	2438	1.10	2.16	2438	1687	1.59	2.18	
1.75	2438	2421	1.12	2.18	2438	1667	1.61	2.18	
2.00	2438	2383	1.14	2.18	2438	1648	1.63	2.18	
2.25	2438	2346	1.16	2.18	2438	1629	1.65	2.18	
2.50	2438	2310	1.18	2.18	2438	1610	1.67	2.18	
2.75	2438	2274	1.20	2.18	2438	1592	1.69	2.18	

Part 9 Buildings Max 3-stories - 8’ Rod Rail In-Fill Systems Maximum Post Spacings									
q 1/50 (kPa)	p (kPa)	Residential One-Two Dwellings				All Other Guards			
		Maximum Post Spacing (mm)		Ultimate Moment at Post-Base Connection (kN-m) ¹		Maximum Post Spacing (mm)		Ultimate Moment at Post-Base Connection (kN-m) ¹	
		2 Post Span	3+ Post Span	2 Post Span	3+ Post Span	2 Post Span	3+ Post Span	2 Post Span	3+ Post Span
		Field zone, Rough terrain^{2,3,4}							
0.4	0.64	2438	2438	1.03	2.04	2438	1758	1.52	2.18
0.48	0.77	2438	2438	1.04	2.06	2438	1747	1.53	2.18
0.58	0.93	2438	2438	1.05	2.08	2438	1733	1.54	2.18
0.63	1.01	2438	2438	1.06	2.10	2438	1727	1.55	2.18
0.78	1.25	2438	2438	1.08	2.13	2438	1707	1.57	2.18
1.0	1.60	2438	2438	1.11	2.18	2438	1679	1.60	2.18
Corner zone, Rough terrain^{2,3,4}									
0.4	0.84	2438	2438	1.05	2.07	2438	1741	1.54	2.18
0.48	1.01	2438	2438	1.06	2.10	2438	1727	1.55	2.18
0.58	1.22	2438	2438	1.08	2.12	2438	1710	1.57	2.18
0.63	1.32	2438	2438	1.08	2.14	2438	1701	1.57	2.18
0.78	1.64	2438	2438	1.11	2.18	2438	1676	1.60	2.18
1.0	2.10	2438	2368	1.15	2.18	2438	1640	1.64	2.18
Field zone, Open terrain^{2,3,4}									
0.4	0.92	2438	2438	1.05	2.08	2438	1734	1.54	2.18
0.48	1.10	2438	2438	1.07	2.11	2438	1719	1.56	2.18
0.58	1.33	2438	2438	1.09	2.14	2438	1700	1.57	2.18
0.63	1.45	2438	2438	1.10	2.16	2438	1691	1.58	2.18
0.78	1.79	2438	2414	1.12	2.18	2438	1664	1.61	2.18
1.0	2.30	2438	2338	1.16	2.18	2438	1625	1.65	2.18
Corner zone, Open terrain^{2,3,4}									
0.4	1.2	2438	2438	1.07	2.12	2438	1711	1.56	2.18
0.48	1.44	2438	2438	1.09	2.16	2438	1692	1.58	2.18
0.58	1.74	2438	2422	1.12	2.18	2438	1668	1.61	2.18
0.63	1.89	2438	2399	1.13	2.18	2438	1656	1.62	2.18
0.78	2.34	2438	2333	1.17	2.18	2438	1622	1.66	2.18
1.0	3.00	2438	2240	1.22	2.18	2438	1574	1.71	2.18

1. Ultimate moment is the factored reaction imparted at the post base in to the structure by the design loads on the guard system.
2. Field zone is a location anywhere not defined as a corner zone.
3. Corner zone as defined by NBCC 4.1.7.5.(5) is within a distance equal to the larger of 0.1W and 0.1D from a building corner, where W and D are the building plan dimensions.
4. Rough and Open terrain are as defined in NBCC 4.1.7.3.(5).



Part 3 Buildings – 6’ Rod Rail In-Fill Systems Maximum Post Spacings									
Wind pressure p (non-factored) as determined by NBCC 4.1.7.3.	p (kPa)	Residential One-Two Dwellings				All Other Guards			
		Maximum Post Spacing (mm)		Ultimate Moment at Post-Base Connection (kN-m) ¹		Maximum Post Spacing (mm)		Ultimate Moment at Post-Base Connection (kN-m) ¹	
		2 Post Span	3+ Post Span	2 Post Span	3+ Post Span	2 Post Span	3+ Post Span	2 Post Span	3+ Post Span
		0.5	1829	1829	0.77	1.52	1829	1770	1.13
0.75	1829	1829	0.78	1.55	1829	1748	1.15	2.18	
1.00	1829	1829	0.80	1.58	1829	1727	1.17	2.18	
1.25	1829	1829	0.82	1.60	1829	1707	1.18	2.18	
1.50	1829	1829	0.83	1.63	1829	1687	1.20	2.18	
1.75	1829	1829	0.85	1.66	1829	1667	1.22	2.18	
2.00	1829	1829	0.87	1.68	1829	1648	1.23	2.18	
2.25	1829	1829	0.88	1.71	1829	1629	1.25	2.18	
2.50	1829	1829	0.90	1.74	1829	1610	1.27	2.18	
2.75	1829	1829	0.91	1.77	1829	1592	1.28	2.18	

Part 9 Buildings Max 3-storeys - 6’ Rod Rail In-Fill Systems Maximum Post Spacings									
q 1/50 (kPa)	p (kPa)	Residential One-Two Dwellings				All Other Guards			
		Maximum Post Spacing (mm)		Ultimate Moment at Post-Base Connection (kN-m) ¹		Maximum Post Spacing (mm)		Ultimate Moment at Post-Base Connection (kN-m) ¹	
		2 Post Span	3+ Post Span	2 Post Span	3+ Post Span	2 Post Span	3+ Post Span	2 Post Span	3+ Post Span
		Field zone, Rough terrain^{2,3,4}							
0.4	0.64	1829	1829	0.78	1.54	1829	1758	1.14	2.18
0.48	0.77	1829	1829	0.78	1.55	1829	1747	1.15	2.18
0.58	0.93	1829	1829	0.79	1.57	1829	1733	1.16	2.18
0.63	1.01	1829	1829	0.80	1.58	1829	1727	1.17	2.18
0.78	1.25	1829	1829	0.82	1.60	1829	1707	1.18	2.18
1.0	1.60	1829	1829	0.84	1.64	1829	1679	1.21	2.18
Corner zone, Rough terrain^{2,3,4}									
0.4	0.84	1829	1829	0.79	1.56	1829	1741	1.16	2.18
0.48	1.01	1829	1829	0.80	1.58	1829	1727	1.17	2.18
0.58	1.22	1829	1829	0.81	1.60	1829	1710	1.18	2.18
0.63	1.32	1829	1829	0.82	1.61	1829	1701	1.19	2.18
0.78	1.64	1829	1829	0.84	1.65	1829	1676	1.21	2.18
1.0	2.10	1829	1829	0.87	1.70	1829	1640	1.24	2.18
Field zone, Open terrain^{2,3,4}									
0.4	0.92	1829	1829	0.79	1.57	1829	1734	1.16	2.18
0.48	1.10	1829	1829	0.81	1.59	1829	1719	1.17	2.18
0.58	1.33	1829	1829	0.82	1.61	1829	1700	1.19	2.18
0.63	1.45	1829	1829	0.83	1.62	1829	1691	1.20	2.18
0.78	1.79	1829	1829	0.85	1.66	1829	1664	1.22	2.18
1.0	2.30	1829	1829	0.89	1.72	1829	1625	1.25	2.18
Corner zone, Open terrain^{2,3,4}									
0.4	1.2	1829	1829	0.81	1.60	1829	1711	1.18	2.18
0.48	1.44	1829	1829	0.83	1.62	1829	1692	1.20	2.18
0.58	1.74	1829	1829	0.85	1.66	1829	1668	1.22	2.18
0.63	1.89	1829	1829	0.86	1.67	1829	1656	1.23	2.18
0.78	2.34	1829	1829	0.89	1.72	1829	1622	1.25	2.18
1.0	3.00	1829	1829	0.94	1.79	1829	1574	1.30	2.18

1. Ultimate moment is the factored reaction imparted at the post base in to the structure by the design loads on the guard system.
2. Field zone is a location anywhere not defined as a corner zone.
3. Corner zone as defined by NBCC 4.1.7.5.(5) is within a distance equal to the larger of 0.1W and 0.1D from a building corner, where W and D are the building plan dimensions.
4. Rough and Open terrain are as defined in NBCC 4.1.7.3.(5).



Part 3 Buildings – 6’ Glass Railing In-Fill Systems Maximum Post Spacings									
Wind pressure p (non-factored) as determined by NBCC 4.1.7.3.	p (kPa)	Residential One-Two Dwellings				All Other Guards			
		Maximum Post Spacing (mm)		Ultimate Moment at Post-Base Connection (kN-m) ¹		Maximum Post Spacing (mm)		Ultimate Moment at Post-Base Connection (kN-m) ¹	
		2 Post Span	3+ Post Span	2 Post Span	3+ Post Span	2 Post Span	3+ Post Span	2 Post Span	3+ Post Span
		0.5	1829	1829	0.84	1.67	1829	1665	1.21
0.75	1829	1829	0.89	1.76	1829	1599	1.26	2.18	
1.00	1829	1829	0.98	1.87	1829	1539	1.31	2.18	
1.25	1829	1799	1.16	2.18	1829	1484	1.36	2.18	
1.50	1829	1566	1.34	2.18	1829	1432	1.47	2.18	
1.75	1829	1388	1.53	2.18	1829	1285	1.65	2.18	
2.00	1829	1249	1.71	2.18	1829	1165	1.83	2.18	
2.25	1829	1136	1.89	2.18	1829	1067	2.02	2.18	
2.50	1829	1044	2.08	2.18	1815	985	2.18	2.18	
2.75	1766	966	2.18	2.18	1674	916	2.18	2.18	

Part 9 Buildings Max 3-storeys - 6’ Glass Railing In-Fill Systems Maximum Post Spacings									
q 1/50 (kPa)	p (kPa)	Residential One-Two Dwellings				All Other Guards			
		Maximum Post Spacing (mm)		Ultimate Moment at Post-Base Connection (kN-m) ¹		Maximum Post Spacing (mm)		Ultimate Moment at Post-Base Connection (kN-m) ¹	
		2 Post Span	3+ Post Span	2 Post Span	3+ Post Span	2 Post Span	3+ Post Span	2 Post Span	3+ Post Span
		Field zone, Rough terrain^{2,3,4}							
0.4	0.64	1829	1829	0.87	1.72	1829	1627	1.23	2.18
0.48	0.77	1829	1829	0.89	1.77	1829	1595	1.26	2.18
0.58	0.93	1829	1829	0.93	1.84	1829	1556	1.30	2.18
0.63	1.01	1829	1829	0.98	1.89	1829	1537	1.31	2.18
0.78	1.25	1829	1801	1.16	2.18	1829	1484	1.36	2.18
1.0	1.60	1829	1489	1.42	2.18	1829	1370	1.54	2.18
Corner zone, Rough terrain^{2,3,4}									
0.4	0.84	1829	1829	0.91	1.80	1829	1577	1.28	2.18
0.48	1.01	1829	1829	0.98	1.89	1829	1537	1.31	2.18
0.58	1.22	1829	1829	1.14	2.18	1829	1491	1.36	2.18
0.63	1.32	1829	1724	1.21	2.18	1829	1468	1.38	2.18
0.78	1.64	1829	1462	1.45	2.18	1829	1347	1.57	2.18
1.0	2.10	1829	1201	1.78	2.18	1829	1123	1.91	2.18
Field zone, Open terrain^{2,3,4}									
0.4	0.92	1829	1829	0.93	1.83	1829	1558	1.29	2.18
0.48	1.10	1829	1829	1.05	2.02	1829	1516	1.33	2.18
0.58	1.33	1829	1713	1.22	2.18	1829	1466	1.38	2.18
0.63	1.45	1829	1608	1.31	2.18	1829	1443	1.43	2.18
0.78	1.79	1829	1361	1.56	2.18	1829	1262	1.68	2.18
1.0	2.30	1829	1116	1.93	2.18	1829	1049	2.05	2.18
Corner zone, Open terrain^{2,3,4}									
0.4	1.2	1829	1829	1.12	2.15	1829	1495	1.35	2.18
0.48	1.44	1829	1616	1.30	2.18	1829	1444	1.42	2.18
0.58	1.74	1829	1395	1.52	2.18	1829	1290	1.64	2.18
0.63	1.89	1829	1306	1.63	2.18	1829	1215	1.75	2.18
0.78	2.34	1829	1101	1.96	2.18	1829	1036	2.08	2.18
1.0	3.00	1632	900	2.18	2.18	1554	857	2.18	2.18

1. Ultimate moment is the factored reaction imparted at the post base in to the structure by the design loads on the guard system.
2. Field zone is a location anywhere not defined as a corner zone.
3. Corner zone as defined by NBCC 4.1.7.5.(5) is within a distance equal to the larger of 0.1W and 0.1D from a building corner, where W and D are the building plan dimensions.
4. Rough and Open terrain are as defined in NBCC 4.1.7.3.(5).

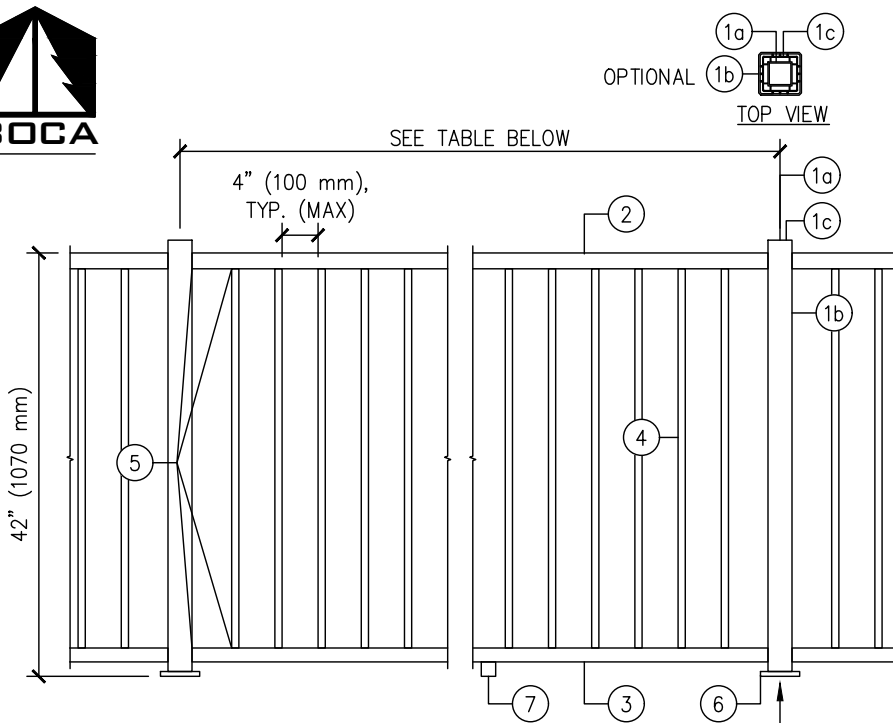

SIGNATURE RAILING COMPONENTS	
1a	ALUMINUM POST
1b	WPC POST SLEEVE (OPTIONAL)
1c	ALUMINUM POST MOUNT SPACER
2	ALUMINUM TOP RAIL
3	ALUMINUM BOTTOM RAIL
4	ALUMINUM SQUARE PICKET
5	CONNECTIONS, SEE TEST REPORT
6	BASEPLATE
7	FOOTBLOCK

SEE TREX SIGNATURE ENGINEERING EVALUATION REPORT TABLES 3 AND 4 FOR MATERIAL SPECIFICATIONS

CONNECTION OF BASEPLATE AND SUB-STRUCTURE DETAILS PER PROJECT DESIGN BY OTHERS, TO COMPLY WITH PART 4 AND/OR PART 9 AS ACCEPTABLE TO AHJ. GUARD DESIGN AT MAXIMUM CAPACITY, REACTION MOMENT AT POST BASE AS PER APPLICABLE INSTALLATION IN TABLES.

A
1 SIGNATURE ALUMINUM RAILING, STANDARD OR POST MOUNT
NOT-TO-SCALE

PART 9 BUILDING (MAX 3-STOUREYS, FIELD/CORNER ZONE, ROUGH/OPEN TERRAIN) – PICKET IN-FILL SYSTEMS									
q _{1/50} (kPa)	p (kPa)	RESIDENTIAL ONE-TWO DWELLINGS				ALL OTHER GUARDS			
		MAXIMUM POST SPACING (mm)		MAXIMUM MOMENT AT POST-BASE CONNECTION (kN-m)		MAXIMUM POST SPACING (mm)		MAXIMUM MOMENT AT POST-BASE CONNECTION (kN-m)	
		2 POST SPAN	3+ POST SPAN	2 POST SPAN	3+ POST SPAN	2 POST SPAN	3+ POST SPAN	2 POST SPAN	3+ POST SPAN
REFER TO TABLES NEXT PAGE									

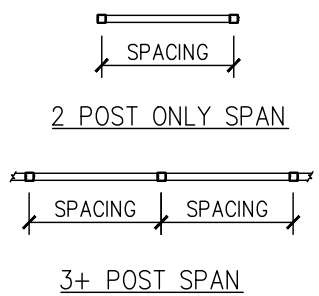

PART 3 BUILDINGS – PICKET IN-FILL SYSTEMS									
WIND PRESSURE p (NON-FACTORED) AS DETERMINED BY NBCC 4.1.7.3.	p (kPa)	RESIDENTIAL ONE-TWO DWELLINGS				ALL OTHER GUARDS			
		MAXIMUM POST SPACING (mm)		MAXIMUM MOMENT AT POST-BASE CONNECTION (kN-m)		MAXIMUM POST SPACING (mm)		MAXIMUM MOMENT AT POST-BASE CONNECTION (kN-m)	
		2 POST SPAN	3+ POST SPAN	2 POST SPAN	3+ POST SPAN	2 POST SPAN	3+ POST SPAN	2 POST SPAN	3+ POST SPAN
REFER TO TABLES NEXT PAGE									

DRAWING FOR ENGINEERING EVALUATION REPORT – NOT FOR USE AS CONSTRUCTION DESIGN DOCUMENTS

COPYRIGHT ©2022 RESERVED. THESE PLANS AND DESIGNS ARE AT ALL TIMES THE PROPERTY OF BOCA ENGINEERING CO. TO BE USED FOR THE PROJECT SHOWN. WRITTEN CONSENT IS REQUIRED FROM THE ENGINEER BEFORE ANY REPRODUCTION.

0	2022/12/31	FOR PUBLICATION	CB
REV	DATE	ISSUE	APP

CLIENT: TREX COMPANY, INC.	PROJECT: TREX SIGNATURE RAILINGS	TITLE: SIGNATURE ALUMINUM RAILING ASSEMBLY AND ALLOWABLE POST SPACING	DRAWING NO. 0078-SK1	DWG SHEET 1 OF 9	DES CB
			DATE DECEMBER 31, 2022		DRN CL
					CHK CB

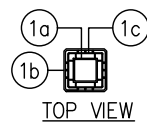

SIGNATURE RAILING COMPONENTS	
1a	ALUMINUM POST
1b	WPC POST SLEEVE (OPTIONAL)
1c	ALUMINUM POST MOUNT SPACER
2	ALUMINUM TOP RAIL
3	ALUMINUM BOTTOM RAIL
4	ALUMINUM RAIL ROD
5	CONNECTIONS, SEE TEST REPORT
6	BASEPLATE
7	FOOTBLOCK
SEE TREX SIGNATURE ENGINEERING EVALUATION REPORT FOR MATERIAL SPECIFICATIONS	

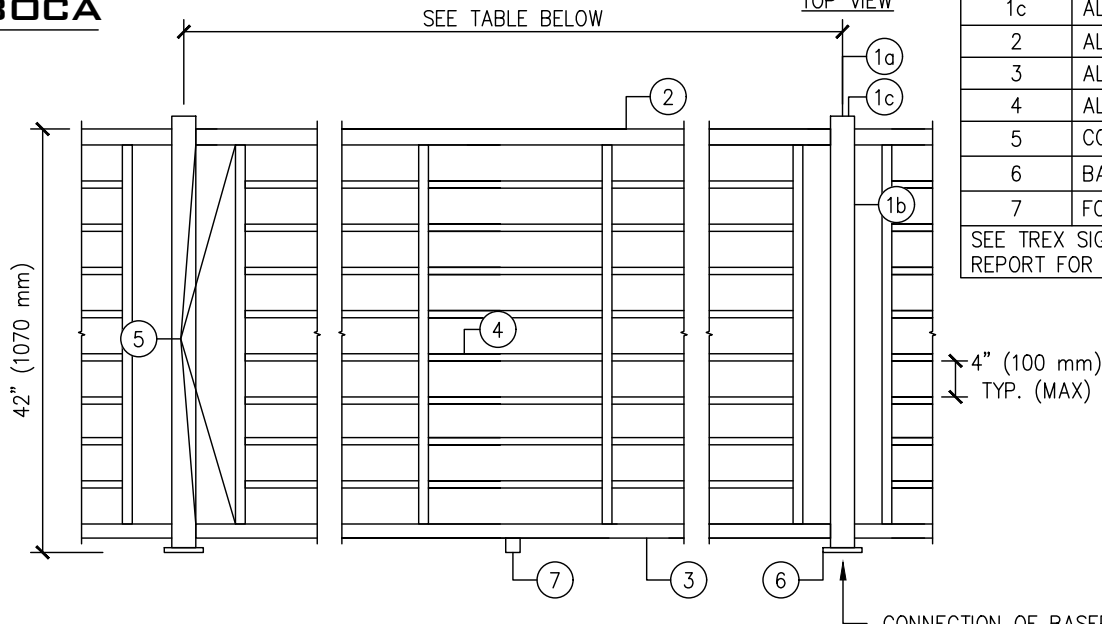

CONNECTION OF BASEPLATE AND SUB-STRUCTURE DETAILS PER PROJECT DESIGN BY OTHERS, TO COMPLY WITH PART 4 AND/OR PART 9 AS ACCEPTABLE TO AHJ. GUARD DESIGN AT MAXIMUM CAPACITY, REACTION MOMENT AT POST BASE AS PER APPLICABLE INSTALLATION IN TABLES.

A SIGNATURE 8 FOOT ROD RAIL, STANDARD OR POST MOUNT
2 NOT-TO-SCALE

PART 9 BUILDING (MAX 3-STOOREYS, FIELD/CORNER ZONE, ROUGH/OPEN TERRAIN) – 8' ROD IN-FILL SYSTEMS									
q _{1/50} (kPa)	p (kPa)	RESIDENTIAL ONE-TWO DWELLINGS				ALL OTHER GUARDS			
		MAXIMUM POST SPACING (mm)		MAXIMUM MOMENT AT POST-BASE CONNECTION (kN-m)		MAXIMUM POST SPACING (mm)		MAXIMUM MOMENT AT POST-BASE CONNECTION (kN-m)	
		2 POST SPAN	3+ POST SPAN	2 POST SPAN	3+ POST SPAN	2 POST SPAN	3+ POST SPAN	2 POST SPAN	3+ POST SPAN
REFER TO TABLES NEXT PAGE									

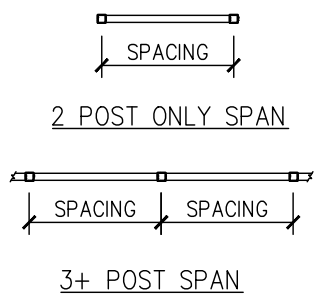

PART 3 BUILDINGS – 8' ROD IN-FILL SYSTEMS									
WIND PRESSURE p (NON-FACTORED) AS DETERMINED BY NBCC 4.1.7.3.	p (kPa)	RESIDENTIAL ONE-TWO DWELLINGS				ALL OTHER GUARDS			
		MAXIMUM POST SPACING (mm)		MAXIMUM MOMENT AT POST-BASE CONNECTION (kN-m)		MAXIMUM POST SPACING (mm)		MAXIMUM MOMENT AT POST-BASE CONNECTION (kN-m)	
		2 POST SPAN	3+ POST SPAN	2 POST SPAN	3+ POST SPAN	2 POST SPAN	3+ POST SPAN	2 POST SPAN	3+ POST SPAN
REFER TO TABLES NEXT PAGE									

DRAWING FOR ENGINEERING EVALUATION REPORT – NOT FOR USE AS CONSTRUCTION DESIGN DOCUMENTS

COPYRIGHT ©2022 RESERVED. THESE PLANS AND DESIGNS ARE AT ALL TIMES THE PROPERTY OF BOCA ENGINEERING CO. TO BE USED FOR THE PROJECT SHOWN. WRITTEN CONSENT IS REQUIRED FROM THE ENGINEER BEFORE ANY REPRODUCTION.

0	2022/12/31	FOR PUBLICATION	CB
REV	DATE	ISSUE	APP
DRAWING NO. 0078-SK1		DWG SHEET 2 OF 9	
DATE DECEMBER 31, 2022		DES CB	DRN CL
		CHK CB	

CLIENT: TREX COMPANY, INC.	PROJECT: TREX SIGNATURE RAILINGS	TITLE: SIGNATURE 8 FOOT ROD RAIL ASSEMBLY AND ALLOWABLE POST SPACING
-------------------------------	-------------------------------------	---

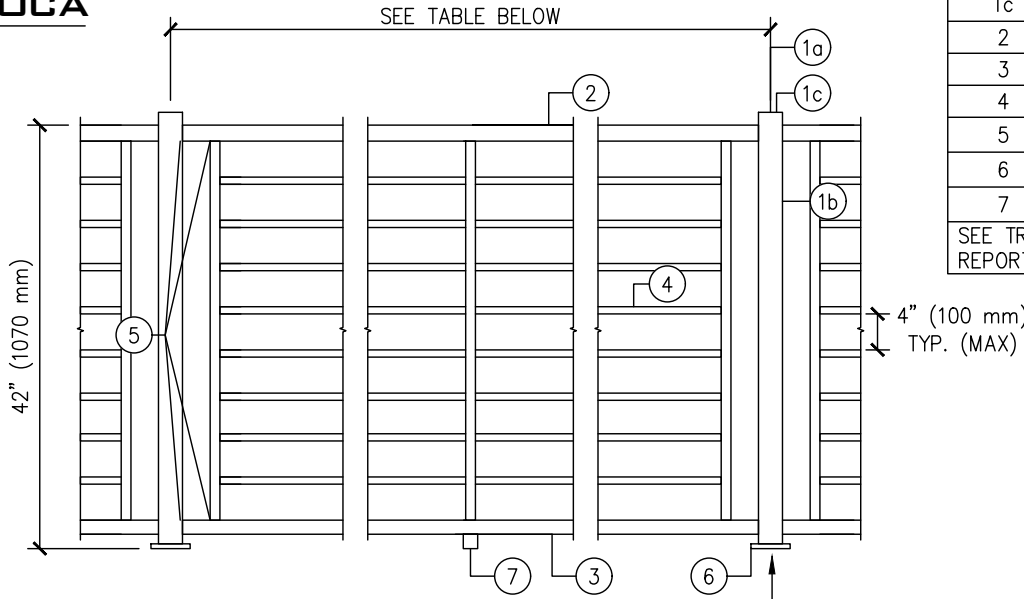
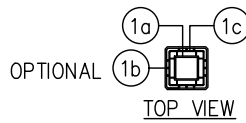

SIGNATURE RAILING COMPONENTS	
1a	ALUMINUM POST
1b	WPC POST SLEEVE (OPTIONAL)
1c	ALUMINUM POST MOUNT SPACER
2	ALUMINUM TOP RAIL
3	ALUMINUM BOTTOM RAIL
4	ALUMINUM RAIL ROD
5	CONNECTIONS, SEE TEST REPORT
6	BASEPLATE
7	FOOTBLOCK
SEE TREX SIGNATURE ENGINEERING EVALUATION REPORT TABLES FOR MATERIAL SPECIFICATIONS	

CONNECTION OF BASEPLATE AND SUB-STRUCTURE DETAILS PER PROJECT DESIGN BY OTHERS, TO COMPLY WITH PART 4 AND/OR PART 9 AS ACCEPTABLE TO AHJ. GUARD DESIGN AT MAXIMUM CAPACITY, REACTION MOMENT AT POST BASE AS PER APPLICABLE INSTALLATION IN TABLES.

A
3 SIGNATURE 6 FOOT ROD RAIL, STANDARD OR POST MOUNT
NOT-TO-SCALE

PART 9 BUILDING (MAX 3-STOUREYS, FIELD/CORNER ZONE, ROUGH/OPEN TERRAIN) – 6' ROD IN-FILL SYSTEMS									
$q_{1/50}$ (kPa)	p (kPa)	RESIDENTIAL ONE-TWO DWELLINGS				ALL OTHER GUARDS			
		MAXIMUM POST SPACING (mm)		MAXIMUM MOMENT AT POST-BASE CONNECTION (kN-m)		MAXIMUM POST SPACING (mm)		MAXIMUM MOMENT AT POST-BASE CONNECTION (kN-m)	
		2 POST SPAN	3+ POST SPAN	2 POST SPAN	3+ POST SPAN	2 POST SPAN	3+ POST SPAN	2 POST SPAN	3+ POST SPAN
REFER TO TABLES NEXT PAGE									

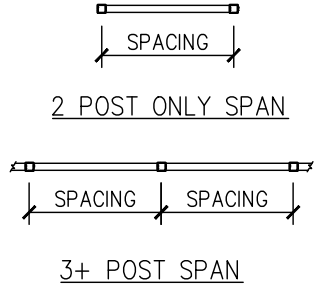

PART 3 BUILDINGS – 6' ROD IN-FILL SYSTEMS									
WIND PRESSURE p (NON-FACTORED) AS DETERMINED BY NBCC 4.1.7.3.	p (kPa)	RESIDENTIAL ONE-TWO DWELLINGS				ALL OTHER GUARDS			
		MAXIMUM POST SPACING (mm)		MAXIMUM MOMENT AT POST-BASE CONNECTION (kN-m)		MAXIMUM POST SPACING (mm)		MAXIMUM MOMENT AT POST-BASE CONNECTION (kN-m)	
		2 POST SPAN	3+ POST SPAN	2 POST SPAN	3+ POST SPAN	2 POST SPAN	3+ POST SPAN	2 POST SPAN	3+ POST SPAN
REFER TO TABLES NEXT PAGE									

DRAWING FOR ENGINEERING EVALUATION REPORT – NOT FOR USE AS CONSTRUCTION DESIGN DOCUMENTS

COPYRIGHT ©2022 RESERVED. THESE PLANS AND DESIGNS ARE AT ALL TIMES THE PROPERTY OF BOCA ENGINEERING CO. TO BE USED FOR THE PROJECT SHOWN. WRITTEN CONSENT IS REQUIRED FROM THE ENGINEER BEFORE ANY REPRODUCTION.

0	2022/12/31	FOR PUBLICATION	CB
REV	DATE	ISSUE	APP

CLIENT: TREX COMPANY, INC.	PROJECT: TREX SIGNATURE RAILINGS	TITLE: SIGNATURE 6 FOOT ROD RAIL ASSEMBLY AND ALLOWABLE POST SPACING	DRAWING NO. 0078-SK1	DES CB
			DWG SHEET 3 OF 9	DRN CL
			DATE DECEMBER 31, 2022	CHK CB

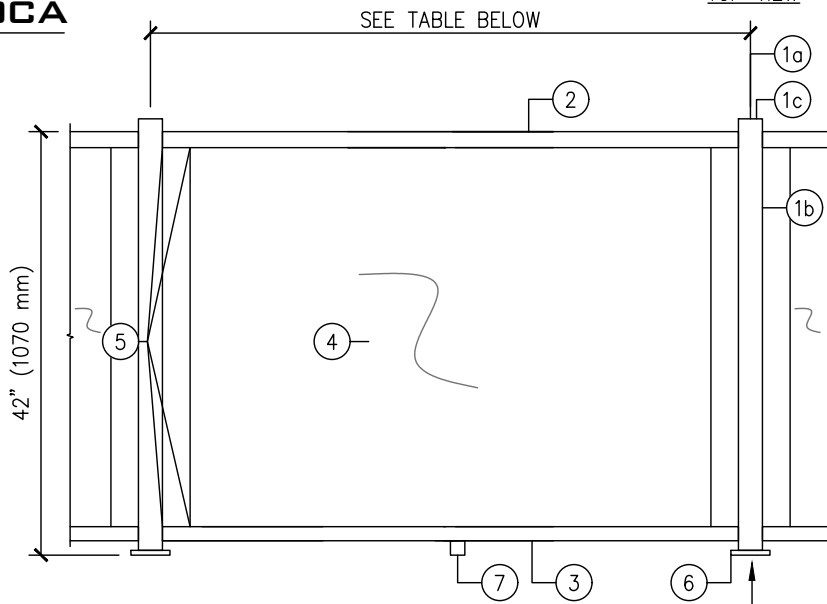
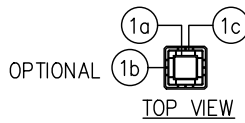

SIGNATURE RAILING COMPONENTS	
1a	ALUMINUM POST
1b	WPC POST SLEEVE (OPTIONAL)
1c	ALUMINUM POST MOUNT SPACER
2	ALUMINUM TOP RAIL
3	ALUMINUM BOTTOM RAIL
4	GLASS INFILL
5	CONNECTIONS, SEE TEST REPORT
6	BASEPLATE
7	FOOTBLOCK

SEE TREX SIGNATURE ENGINEERING EVALUATION REPORT TABLES FOR MATERIAL SPECIFICATIONS

CONNECTION OF BASEPLATE AND SUB-STRUCTURE DETAILS PER PROJECT DESIGN BY OTHERS, TO COMPLY WITH PART 4 AND/OR PART 9 AS ACCEPTABLE TO AHJ. GUARD DESIGN AT MAXIMUM CAPACITY, REACTION MOMENT AT POST BASE AS PER APPLICABLE INSTALLATION IN TABLES.

A SIGNATURE GLASS RAILING, STANDARD OR POST MOUNT
4 NOT-TO-SCALE

PART 9 BUILDING (MAX 3-STOUREYS, FIELD/CORNER ZONE, ROUGH/OPEN TERRAIN) – GLASS IN-FILL SYSTEMS									
$q_{1/50}$ (kPa)	p (kPa)	RESIDENTIAL ONE-TWO DWELLINGS				ALL OTHER GUARDS			
		MAXIMUM POST SPACING (mm)		MAXIMUM MOMENT AT POST-BASE CONNECTION (kN-m)		MAXIMUM POST SPACING (mm)		MAXIMUM MOMENT AT POST-BASE CONNECTION (kN-m)	
		2 POST SPAN	3+ POST SPAN	2 POST SPAN	3+ POST SPAN	2 POST SPAN	3+ POST SPAN	2 POST SPAN	3+ POST SPAN
REFER TO TABLES NEXT PAGE									

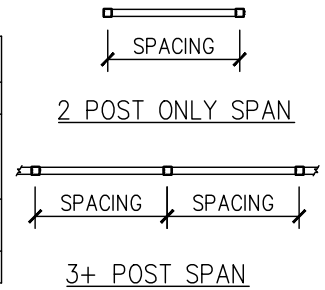

PART 3 BUILDINGS – GLASS IN-FILL SYSTEMS									
WIND PRESSURE p (NON-FACTORED) AS DETERMINED BY NBCC 4.1.7.3.	p (kPa)	RESIDENTIAL ONE-TWO DWELLINGS				ALL OTHER GUARDS			
		MAXIMUM POST SPACING (mm)		MAXIMUM MOMENT AT POST-BASE CONNECTION (kN-m)		MAXIMUM POST SPACING (mm)		MAXIMUM MOMENT AT POST-BASE CONNECTION (kN-m)	
		2 POST SPAN	3+ POST SPAN	2 POST SPAN	3+ POST SPAN	2 POST SPAN	3+ POST SPAN	2 POST SPAN	3+ POST SPAN
REFER TO TABLES NEXT PAGE									

DRAWING FOR ENGINEERING EVALUATION REPORT – NOT FOR USE AS CONSTRUCTION DESIGN DOCUMENTS

COPYRIGHT ©2022 RESERVED. THESE PLANS AND DESIGNS ARE AT ALL TIMES THE PROPERTY OF BOCA ENGINEERING CO. TO BE USED FOR THE PROJECT SHOWN. WRITTEN CONSENT IS REQUIRED FROM THE ENGINEER BEFORE ANY REPRODUCTION.

0	2022/12/31	FOR PUBLICATION	CB
REV	DATE	ISSUE	APP

CLIENT: TREX COMPANY, INC.	PROJECT: TREX SIGNATURE RAILINGS	TITLE: SIGNATURE GLASS RAILING ASSEMBLY AND ALLOWABLE POST SPACING	DRAWING NO. 0078-SK1	DWG SHEET 4 OF 9	DES CB
			DATE DECEMBER 31, 2022		DRN CL
					CHK CB

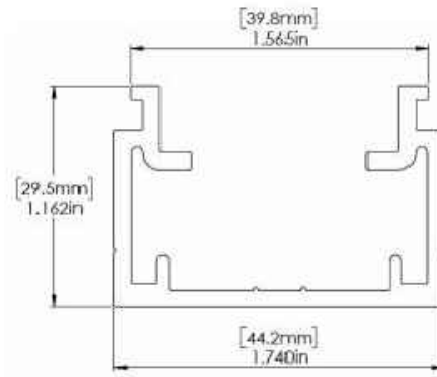
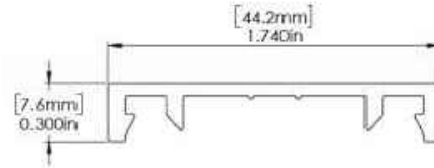
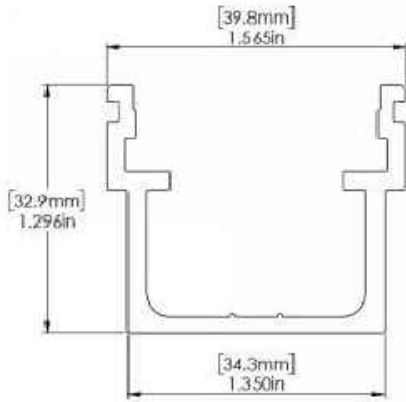
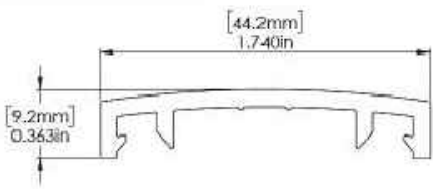

A
5 TOP RAIL
NOT-TO-SCALE

B
5 BOTTOM RAIL
NOT-TO-SCALE

COMPONENTS: ALUMINUM RAILING & ROD RAIL SYSTEM

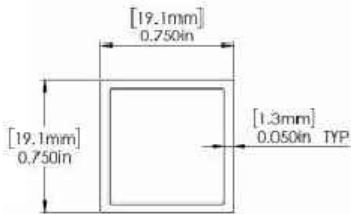

C
5 BALUSTER (PICKET)
NOT-TO-SCALE

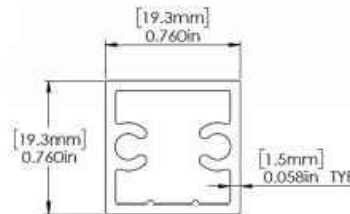

D
5 MIDDLE (PINNED) BALUSTER
NOT-TO-SCALE

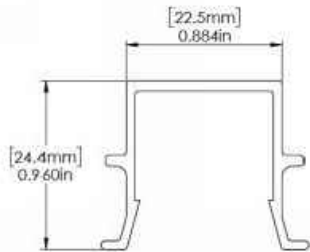

E
5 RAIL INSERT
NOT-TO-SCALE

COMPONENTS: PICKET IN-FILL ALUMINUM RAILING SYSTEM

DRAWING FOR ENGINEERING
EVALUATION REPORT – NOT
FOR USE AS CONSTRUCTION
DESIGN DOCUMENTS

COPYRIGHT ©2022 RESERVED. THESE PLANS AND DESIGNS ARE AT ALL TIMES THE PROPERTY OF BOCA ENGINEERING CO.
TO BE USED FOR THE PROJECT SHOWN. WRITTEN CONSENT IS REQUIRED FROM THE ENGINEER BEFORE ANY REPRODUCTION.

CLIENT:

TREX COMPANY, INC.

PROJECT:

TREX SIGNATURE RAILINGS

TITLE:

COMPONENT DRAWINGS I

0	2022/12/31	FOR PUBLICATION	CB
REV	DATE	ISSUE	APP
DRAWING NO. 0078-SK1		DWG SHEET 5 OF 9	DES CB
DATE DECEMBER 31, 2022			DRN CL
			CHK CB

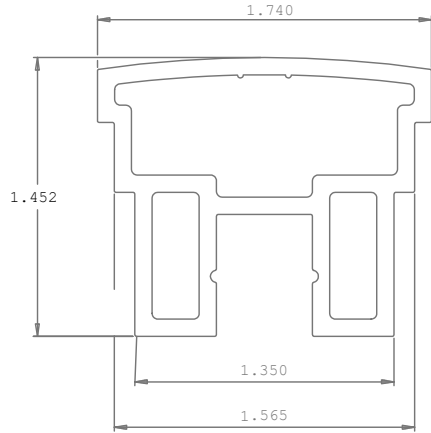

A
6 UPPER RAIL EXTRUSION
NOT-TO-SCALE

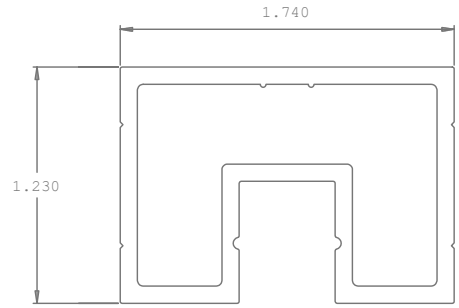

B
6 LOWER RAIL EXTRUSION
NOT-TO-SCALE

COMPONENTS: GLASS RAIL SYSTEM

DRAWING FOR ENGINEERING
EVALUATION REPORT – NOT
FOR USE AS CONSTRUCTION
DESIGN DOCUMENTS

COPYRIGHT ©2022 RESERVED. THESE PLANS AND DESIGNS ARE AT ALL TIMES THE PROPERTY OF BOCA ENGINEERING CO.
TO BE USED FOR THE PROJECT SHOWN. WRITTEN CONSENT IS REQUIRED FROM THE ENGINEER BEFORE ANY REPRODUCTION.

CLIENT: TREX COMPANY, INC.	PROJECT: TREX SIGNATURE RAILINGS	TITLE: COMPONENT DRAWINGS II
-------------------------------	-------------------------------------	---------------------------------

0	2022/12/31	FOR PUBLICATION	CB
REV	DATE	ISSUE	APP
DRAWING NO. 0078-SK1		DWG SHEET 6 OF 9	DES CB
DATE DECEMBER 31, 2022			DRN CL
			CHK CB

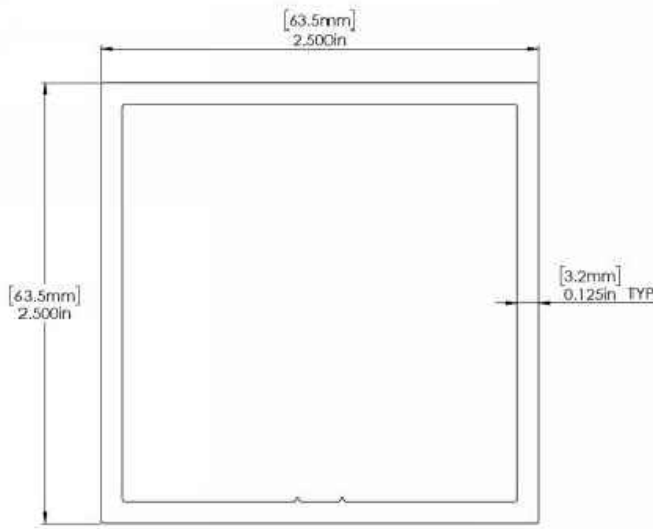

A
7 POST
NOT-TO-SCALE

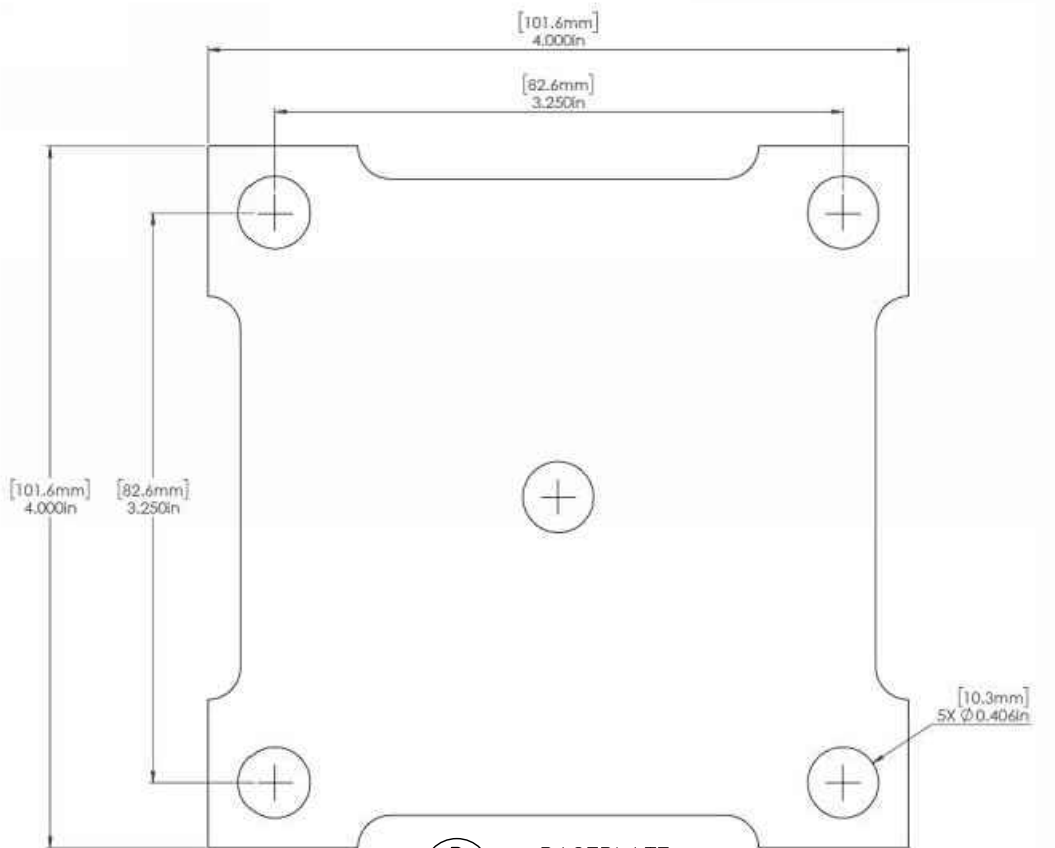

B
7 BASEPLATE
NOT-TO-SCALE

DRAWING FOR ENGINEERING
EVALUATION REPORT – NOT
FOR USE AS CONSTRUCTION
DESIGN DOCUMENTS

COMPONENTS: TYPICAL ALL SYSTEMS

COPYRIGHT ©2022 RESERVED. THESE PLANS AND DESIGNS ARE AT ALL TIMES THE PROPERTY OF BOCA ENGINEERING CO. TO BE USED FOR THE PROJECT SHOWN. WRITTEN CONSENT IS REQUIRED FROM THE ENGINEER BEFORE ANY REPRODUCTION.

CLIENT: TREX COMPANY, INC.	PROJECT: TREX SIGNATURE RAILINGS	TITLE: COMPONENT DRAWINGS III
-------------------------------	-------------------------------------	----------------------------------

0	2022/12/31	FOR PUBLICATION	CB
REV	DATE	ISSUE	APP
DRAWING NO. 0078-SK1		DWG SHEET 7 OF 9	
DATE DECEMBER 31, 2022		DES CB	DRN CL
		CHK CB	

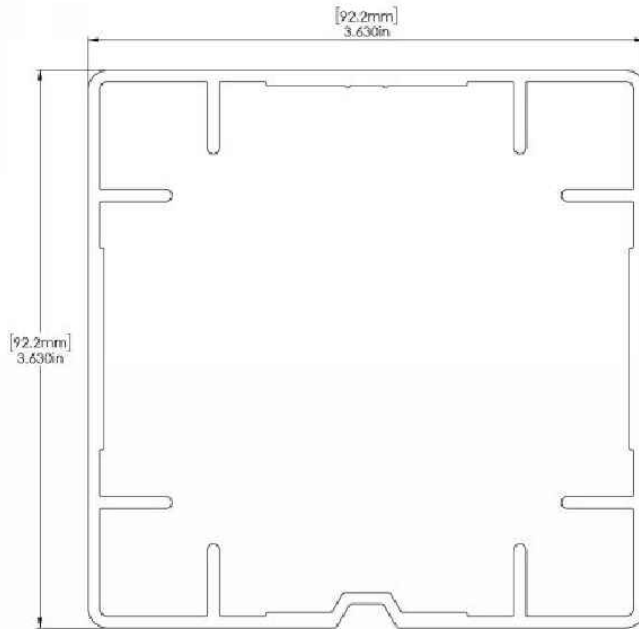

A
8 POST MOUNT SPACER
NOT-TO-SCALE

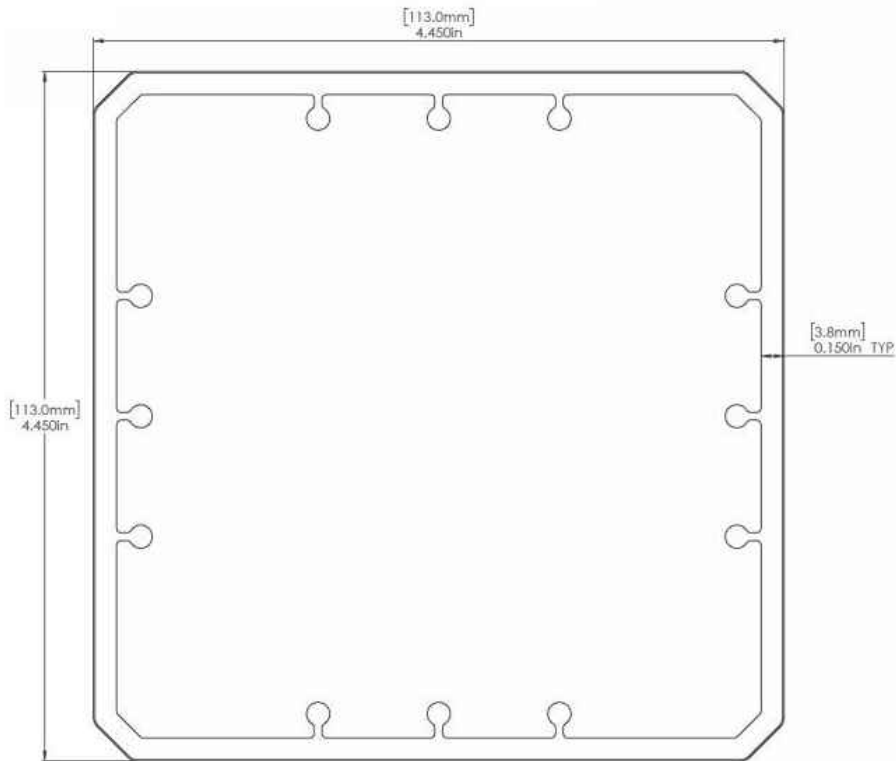

B
8 POST SLEEVE
NOT-TO-SCALE

COMPONENTS: TYPICAL ALL SYSTEMS

DRAWING FOR ENGINEERING
EVALUATION REPORT – NOT
FOR USE AS CONSTRUCTION
DESIGN DOCUMENTS

COPYRIGHT ©2022 RESERVED. THESE PLANS AND DESIGNS ARE AT ALL TIMES THE PROPERTY OF BOCA ENGINEERING CO. TO BE USED FOR THE PROJECT SHOWN. WRITTEN CONSENT IS REQUIRED FROM THE ENGINEER BEFORE ANY REPRODUCTION.

CLIENT: TREX COMPANY, INC.	PROJECT: TREX SIGNATURE RAILINGS	TITLE: COMPONENT DRAWINGS IV
-------------------------------	-------------------------------------	---------------------------------

0	2022/12/31	FOR PUBLICATION	CB
REV	DATE	ISSUE	APP
DRAWING NO. 0078-SK1 DWG SHEET 8 OF 9			DES CB
DATE DECEMBER 31, 2022			DRN CL
			CHK CB

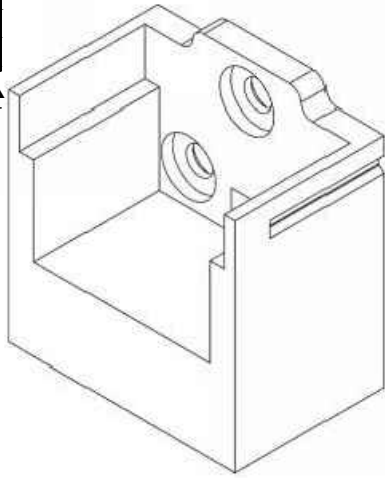

A
9 — TOP RAIL BRACKET
NOT-TO-SCALE

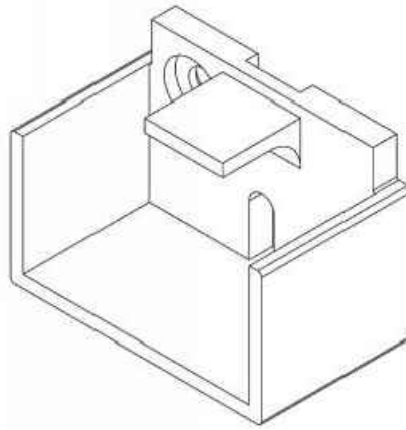

B
9 — BOTTOM RAIL BRACKET
NOT-TO-SCALE

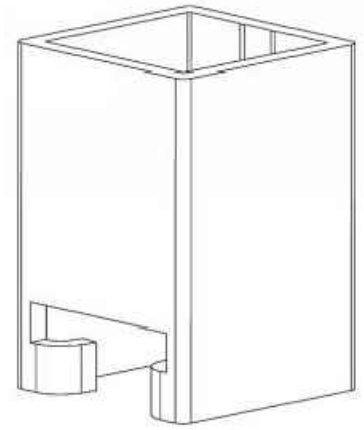

C
9 — FOOTBLOCK
NOT-TO-SCALE

COMPONENTS: TYPICAL ALL SYSTEMS

DESIGN LOADS	
LIVE (GUARD)	SEE EVALUATION REPORT
SNOW	
WIND	
TEMPERATURE	

LEGEND AND SYMBOLS

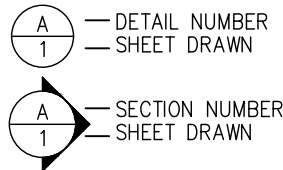

INSTALLATION

- FOR COMPLETE INSTALLATION DETAILS SEE TECHNICAL PRODUCT DATA ON PRODUCT MANUFACTURE'S WEBSITE.

MATERIAL STANDARDS

FASTENERS

- WOOD SCREWS: ASME B18.6.1-81(2016)
- NAILS: ASTM F1667-15
- METAL SCREWS: AISI S240-15, ASTM C1513-13
- ALL FASTENERS CORROSION-RESISTANT OR STAINLESS STEEL

FRAMING

- WOOD FRAMING: MIN. 2x4 S.G. 0.42, COMPLIANCE WITH CSA 0141-05
- METAL FRAMING: MIN. 18 GAUGE U.N.O., Fy = 33ksi, COMPLIANCE WITH CSA S136-12

INSPECTIONS (FIELD REVIEWS)

- NOTIFICATION FOR INSPECTIONS AND INSTALLATION APPROVAL SHOULD BE COMPLETED AS OUTLINED BY ANY OF THE FOLLOWING APPLICABLE TO THE REFERENCED PROJECT:
 - APPLICABLE LOCAL BUILDING CODE.
 - LOCAL BUILDING AUTHORITY.
 - PROJECT SPECIFICATION DOCUMENTS BY OTHERS.
- FIELD REVIEWS OF INSTALLATION ARE NOT COMPLETED BY THE EVALUATION REPORT ENGINEER.

ABBREVIATIONS

CONT	CONTINUOUS	O.C.	ON CENTER
EA	EACH	P.T.	PRESSURE TREATED
E/W	EACH WAY	S.G.	SPECIFIC GRAVITY
EXT.	EXTERIOR	SPEC.	SPECIFICATION
INT.	INTERIOR	NO.	TYPICAL
MAX	MAXIMUM	U.N.O.	UNLESS NOTED OTHERWISE
MIN	MINIMUM	W/	WITH
NO.	NUMBER		

DESIGN

- STRUCTURAL WORK HAS BEEN DESIGNED IN ACCORDANCE WITH APPLICABLE CODES AND STANDARDS REFERENCED IN THE EVALUATION REPORT.
- THE STRUCTURAL FRAMING AND SHEATHING SHALL BE DESIGNED AND ANCHORED TO PROVIDE LATERAL BRACING AND PROPERLY TRANSFER ALL LOADS TO THE STRUCTURE. FRAMING DESIGN AND INSTALLATION IS THE RESPONSIBILITY OF THE ENGINEER OR ARCHITECT OF RECORD FOR THE PROJECT OF INSTALLATION.
- THESE DRAWINGS APPLY TO THE TESTED ASSEMBLY ONLY AND DO NOT IMPLY THAT THE SIGNATORY ENGINEER IS THE DESIGNER OF RECORD FOR ANY FUTURE CONSTRUCTION ON WHICH THEY ARE USED.

TESTING AND CODE COMPLIANCE

- THE PRODUCT ASSEMBLY SHOWN HAS BEEN EVALUATED ACCORDING TO THE TEST STANDARDS AS OUTLINED IN THE EVALUATION REPORT.
- THE INSTALLATION DETAILS DESCRIBED ARE OF THE LABORATORY TESTED ASSEMBLY AND MAY NOT REFLECT ACTUAL CONDITIONS FOR A SPECIFIC SITE. IF SITE CONDITIONS DEVIATE FROM THE REQUIREMENTS DETAILED HEREIN, THE LICENSED ENGINEER OR ARCHITECT PREPARED SITE-SPECIFIC DOCUMENTS SHALL BE USED.

COPYRIGHT ©2022 RESERVED. THESE PLANS AND DESIGNS ARE AT ALL TIMES THE PROPERTY OF BOCA ENGINEERING CO. TO BE USED FOR THE PROJECT SHOWN. WRITTEN CONSENT IS REQUIRED FROM THE ENGINEER BEFORE ANY REPRODUCTION.

DRAWING FOR ENGINEERING EVALUATION REPORT – NOT FOR USE AS CONSTRUCTION DESIGN DOCUMENTS

CLIENT: TREX COMPANY, INC.	PROJECT: TREX SIGNATURE RAILINGS	TITLE: COMPONENT DRAWINGS V & GENERAL NOTES	0 REV	2022/12/31 DATE	FOR PUBLICATION ISSUE	CB APP
			DRAWING NO. 0078-SK1		DES CB	
			DATE DECEMBER 31, 2022		DRN CL	
					CHK CB	



ATTACHMENT 4: DISCUSSION OF LIMIT STATES DESIGN PROCEDURE

Load Combinations, Load and Resistance Factors, Test Factors

Applying load combinations of live plus wind in solid and open in-fill guard systems is required by the NBCC (see ref. Section F.24 of User's Guide – NBC 2015, Structural Commentaries and CSA A500-16 Section 4.2.3 Load Combinations for normative information).

Design of configured structural systems by strength testing of assemblies with a test load (safety) factor in limit states design necessitates the computation of a test load factor for the respective stress and failure type due to the various loading types of guards. Deflection limits are measured at the service-level load combinations. Members are typically stressed to ultimate states in bending or in shear, depending on the placement of the test load with respect to the connection/support of the member.

Test Load Factors are computed by:

$$\text{Test Load Factor} = \frac{\text{Combined Load Factor}}{\text{Resistance Factor}}$$

The resistance factor is taken from the materials standard for the respective stress type (e.g. shear stress on fillet welds: on ultimate, $\Phi_f = 0.67$, as per CSA S157).

With load combinations, the combined load factor is equal to:

$$\text{Combined Test Load Factor} = \frac{\text{Total Combined Ultimate (Factored) Load}}{\text{Total Combined Service Load}}$$

The test load becomes:

$$\text{Test Load} = (\text{Combined Test Load Factor}) \times (\text{Total Combined Service Load})$$

The test load factors ranged from 1.95 – 2.25 times the combined (live + wind) service-level design loads evaluated, dependent on the load placement and the ratio of live to wind load respectively, for each design test load.

Aluminum Components

The design analysis of the aluminum components has been carried out in accordance with and complies with CSA S157-05, *Strength Design in Aluminum*, Section 6 Methods of Analysis and Design. More specifically, Section 6.2 Testing, where it states “the adequacy of a structural assembly may be determined by tests in accordance with Section 13.” Where Section 13.2.2 states, “... tests shall be conducted to accepted procedures, such as provided by an appropriate ASTM standard...” which is ASTM E935-13, *Standard Test Methods for Performance of Permanent Metal Railing Systems and Rails for Buildings*.

Glass Components

CGSB 12.20-89 includes some guidance on applications of glass in guard balustrades. Following section 6 of the standard, factored design loads were found not to exceed the factored resistance of $\frac{1}{4}$ " tempered glass test panels. Deflection limits from the standard were imposed and ultimate test factor of 2 was taken when applied to glass.

Fasteners

Common corrosion-resistant steel screws are used at the connections. The steel strength properties taken by design to CSA S16-14, *Design of Steel Structures*, are verified for the application by the system testing procedure.

- END -