



2021 INSTALLATION GUIDE



WHAT'S NEW FOR 2021:

- » **Page 23** Revised decking skus
- » **Page 24** Revised decking and fascia recommended fasteners
- » **Page 26** Revised framing and fastening tips
- » **Page 50** Revised railing skus
- » **Page 56** Updated railing instructions
- » **Page 85** Added crossover bracket instructions
- » **Page 162** Added curved mesh instructions
- » **Page 212** Added open joint cladding instructions
- » **Page 222** Revised decking color palette

NEED HELP?

Trex provides a variety of valuable resources to answer your questions or concerns. For additional assistance, check out:

- » **Trex.com**
Here you will find a wealth of useful information on Trex's extensive products including: installation, care and cleaning instructions and videos, technical help, and FAQs. You'll also find inspiring photos of deck projects, steps to help you plan and start your project, and tips for selecting the right deck builder. At **trex.com**, you can request information, register your warranty, and reach out to customer service representatives who can answer even more questions.
- » Call **1-800-BUY-TREX (1-800-289-8739)** and speak to a Customer Loyalty Advocate who can answer your questions.

Refer to **www.trex.com** for up-to-date installation and technical documents that may not be found in this printed guide.



This symbol indicates text continues to next page.

NOTE: Construction methods are always improving. Please refer to www.trex.com for the most up-to-date installation requirements.

TREX INSTALLATION GUIDE

CONTENTS

SECTION ONE: General Information

Safety	5
Tools	5
Care and Cleaning	6

SECTION TWO: Planning Ahead

Trex Decking	10
Railing (Including ADA Handrail)	10
Trex Lighting	10
Trex® RainEscape® Drainage System	10
Installing Hot Tubs, Planters, and Seating	10
Installing Fireplaces and/or Fire Pits	11
Installing a Pergola	11
Installing Trex® Spiral Stairs™	11
Installing Trex® Outdoor Kitchens™	11

SECTION THREE: Lighting

How to Install Trex® Outdoor Lighting™

Outdoor Lighting SKUs	13
Parts List/Tools Needed	14
Lighting and Wiring Overview	14
Helpful Tips	14
General Information	15
Planning	15
Installing Wiring	15
Making Connections	15
Timer Operation Instructions	16
Installing Post Cap Lights	16
Installing Deck Rail Lights	16
Installing Riser Lights	17
Installing Recessed Deck Lights	17
How to Program Dimmer Remote	18

How to Install Trex Signature® Post Cap Light

Parts List/Tools Needed	19
Helpful Tips	19
Installing Post Cap Lights	19

How to Install Trex® Wedge Deck Rail Light

Parts List/Tools Needed	20
Helpful Tips	20

SECTION FOUR: Decking

Decking, Porch Flooring & Fascia SKUs	23
Decking and Fascia Recommended Fasteners	24
Trex® Fascia Installation Recommendations	25
Framing and Fastening Tips	26
Rooftop and Sleeper Deck Systems	27
Metal Framing Requirements and Gapping	28
Code Compliance	29
Gapping and Overhang	30

How to Install Decking

Important Notes Before Installing Trex Decking	31
Routing Square Edged Boards for Trex Hideaway®	31
Hidden Fasteners	31
Abutted Board Attachment Requirements	31
Metal Framing	31
Installing Trex Transcend®, Enhance®, Select®	31
Deck Boards	32

Replacing Trex Boards	33
Spanning Requirements For Trex Stairs	34
Stairs	34
Installing Trex Stair Treads	
Installed with Hidden Fasteners	35
Location and Installation of Surface Mount	
Post - Decking	36
Parts List/Tools and Materials Needed	36
How to Install Post Mounts on Pressure-Treated	
Wood Framing	36
Corner Post Installation	36
Line Post Installation	36
How to Install Guide Blocks	37
How to Install Railing System of Choice	38
Location and Installation of Post Mounts - Concrete	38
Parts List/Tools Needed	38
How to Install Guide Blocks	39
How to Install Railing System of Choice	39
How to Install Joist Mount Posts	
Parts List/Tools Needed	40
Inside Mount	
Front Rim Plate - Between Joists	41
Front Rim Plate - Next to Joist	41
Side Joist	42
Corner	43
Composite Post Sleeve Applications	
Installation of Guide Blocks and Railing	44
Fascia Mount	
Front Rim Plate - Next to Joist	45
Side Joist - With Blocking	46
Outside Frame Corner	47

SECTION FIVE: Railing

Post Sleeves, Caps and Skirts SKUs	50
Trex Signature Aluminum Railing SKUs	51
Trex Transcend Railing SKUs	53
Trex Select Railing SKUs	54
Aluminum Gates SKUs	55
Aluminum ADA Compliant Handrail SKUs	55

Trex Transcend® Railing

Parts List/Determining Balusters Needed	56
Railing Configurations	57
How to Install Standard Railing	58
How to Install Cocktail Railing	60
How to Install Traditional Railing	61
How to Install Round or Square Aluminum	
Balusters	62
How to Install Standard Glass Panel Railing	63
How to Install Cocktail Style Glass Panel Railing	65
How to Install Traditional Style Glass Panel Railing	66
How to Install On-An-Angle Railing	68
How to Install Crown and Universal Bird's	
Mouth Railing	68
Parts List/Determining Balusters Needed -	
Stair	70
Stair Rail Configurations	71

TREX INSTALLATION GUIDE

CONTENTS/CONTINUED

How to Install Standard Stair Railing	72	How to Install Crossover Swivel Brackets.....	150
How to Install Cocktail Stair Railing.....	76	How to Install Cocktail Rod Rail Stair Railing.....	152
How to Install Traditional Stair Railing.....	78	How to Install Traditional Rod Rail Stair Railing.....	154
Trex Signature® Railing		Trex Signature® Glass Railing	
Parts List/Determining Balusters Needed	79	Parts List/Tools Needed.....	155
Installing Trex Signature Posts and/or Trex Signature		How to Install Horizontal Glass Railing.....	156
Crossover Posts on Wood or Concrete.....	80	Trex Signature® Mesh Railing	
Installing Pressure-Treated Post, Post Sleeves,		Parts List/Tools Needed - Horizontal Mesh.....	162
and Skirts to Use with Trex Signature Railing.....	81	Horizontal Mesh Configurations.....	163
Installing Trex Signature Posts on Concrete	81	How to Install Horizontal Mesh Railing.....	166
Railing Configurations.....	82	How to Install Cocktail Mesh Railing	172
Bracket Hardware – Horizontal Applications	83	How to Install Traditional Mesh Railing	173
How to Install Horizontal Railing.....	84	Parts List/Tools Needed - Stair Rail Mesh.....	175
How to Install Horizontal Line and		How to Install Stair Mesh Railing.....	176
Crossover Brackets.....	85	How to Install Cocktail Stair Mesh Railing	187
How to Install Horizontal Railing Post to Post	87	How to Install Traditional Stair Mesh Railing	189
How to Install Horizontal Railing Post to		Trex Aluminum Gate	
Crossover Post.....	91	How to Install Aluminum Gate	190
How to Install Horizontal Railing Crossover Post		Trex Select® Railing	
to Crossover Post	94	Parts List/Determining Balusters Needed -	
How to Install Cocktail Railing	98	Horizontal Rail.....	192
How to Install Traditional Railing	99	Horizontal Railing Configurations.....	193
How to Install Horizontal Swivel Brackets	101	How to Install Horizontal Standard Railing	194
How to Install Horizontal Swivel Railing	102	How to Install Horizontal Cocktail Railing.....	196
Bracket Hardware – Stair Applications	104	How to Install Traditional Railing	198
How to Install Stair Posts and		How to Install On-An-Angle Railing.....	199
Stair Railing	105	Parts List/Determining Balusters Needed -	
Attaching Fixed Stair Brackets and Rails to		Stair Railing Applications.....	200
Trex Signature Posts and Pressure-Treated Posts		Stair Railing Configurations.....	201
and Post Sleeves.....	106	How to Install Standard Stair Railing	202
Attaching Stair Swivel/Compound Swivel		How to Install Cocktail Stair Railing.....	205
Brackets And Rails To Trex Signature Posts		How to Install Traditional Stair Railing.....	207
And Pressure-Treated Post And Post Sleeves... 110		Trex Aluminum ADA Compliant Handrail	
Attaching Crossover Swivel Bracket On		ADA Handrail Guidelines	209
Trex Signature Post	113	Ramp Application	209
Attaching Stair Rails In Crossover Post		ADA Railing Profiles.....	210
Applications.....	114	Hardware.....	210
How To Install Signature Cocktail Stair Railing	116	How to Install Trex Aluminum ADA Compliant	
How To Install Signature Traditional Stair Railing	118	90° Wall Return.....	211
How to Install Signature Horizontal Curved Railing....	121	Wall Mount.....	211
Trex Signature® Panels		Inline Bracket.....	211
Parts List/Tools Needed.....	124	Rail-to-Rail Connections/Internal Connector	211
Bracket Hardware – Horizontal Applications	125	Handrail Return 180°	212
How to Install Panels	126	Adjustable Elbow.....	212
Trex Signature® Rod Railing		Elbows (90°, 36°, 34°, 31°, 5°).....	212
Parts List/Tools Needed.....	130	Corner Mount	212
Railing Configurations.....	131	Transcend Cladding	
Bracket Hardware – Horizontal Rail Applications	132	How To Install Open-Joint Cladding	213
How to Install Horizontal Brackets.....	133	SECTION SIX: Warranties	
How to Install Horizontal Standard Rod Railing.....	135	Trex Transcend®, Trex Enhance®, Trex Select®, and Trex®	
How to Install Horizontal Cocktail Rod Railing.....	139	Universal Fascia Limited Fade & Stain Warranty.....	219
How to Install Horizontal Traditional Rod Railing.....	141	Trex® Limited Warranty	221
Bracket Hardware – Rod Rail Stair Applications	142	Trex Signature®/Reveal® Railing Limited Warranty	222
How to Install Standard Rod Rail Stair Railing.....	144	Color Palette.....	223

SAFETY

When working on any construction project, you should wear protective clothing and safety equipment. Wear safety glasses, gloves, a dust mask and long sleeves, particularly when cutting in confined spaces.

Trex decking and railing are heavier and more flexible than wood. **DO NOT** try to lift the same quantity of Trex boards as you would traditional lumber. Go to www.trex.com for Safety Data Sheets (SDS).

TOOLS

SAWS

Miter Saw:

When using a miter saw we recommend using the Trex® Blade™ or a carbide-tipped blade with 60 teeth or more. The Trex Blade comes in three different sizes and is ideal for cutting all Trex decking and railing products.

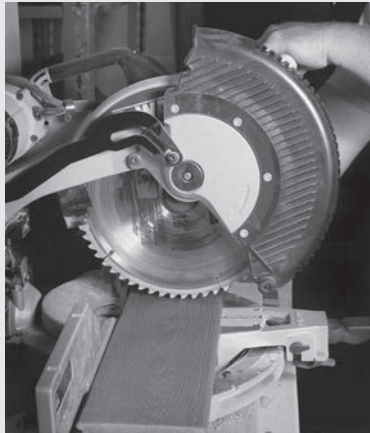

Jigsaw:

For detailed and/or small cuts (Example: cutting deck board to fit around a post), a jigsaw with a carbide-tipped blade can be used.



DRILLS

Install Trex recommended fasteners with standard power drills, impact drivers (use care if using impact drivers), or right angle drills.



*Trex Blade™ is manufactured and sold by Freud Tools, Inc. under a Trademark License Agreement with Trex Company, Inc.

SPECIFIC DECK BOARD ATTACHMENT TOOLS

Screw Guns:

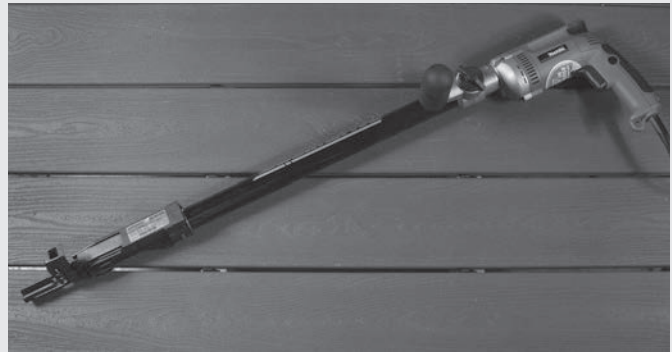

Some Trex recommended deck fasteners are compatible with screw guns. Refer to the recommended fasteners page for more information.

TigerClaw® Pneumatic Gun:

If choosing to use the TigerClaw TC-G Hidden Fasteners the TigerClaw pneumatic gun is a terrific option that allows for quicker install time.



Trex Router Bit:

Trex decking routs to give extremely crisp edges when using the Trex Router Bit with standard router, and can be used with all Trex Hideaway Hidden Fasteners.

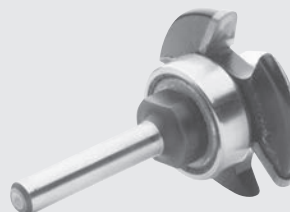

*Tiger Claw® is a registered trademark of Tiger Claw, Inc.

TREX TRANSCEND®, TREX ENHANCE®, AND TREX SELECT® CARE AND CLEANING GUIDE

All exterior building materials require cleaning. Generally, soap and water is all that is required to clean Transcend, Enhance, and Select products. For additional information, see below.

PROBLEM	SOLUTION
Dirt and Debris	The affected area should be sprayed off with a hose to remove surface debris. Use warm soapy water and a soft bristle brush to remove dirt and debris from the embossing pattern.
Using a Pressure Washer (General Cleaning Issues)	A pressure washer with no greater than 3100 psi* that has a fan attachment/adjustment and soap dispenser may be used to remove dirt or mud. Spray deck with soap, then follow by gently scrubbing each deck board with a soft bristle brush. Spray/rinse each individual deck board using a fan tip no closer than 8-in (203 mm) from the decking surface. RINSE THOROUGHLY. If dirty water from cleaning is left to dry, a film will remain on the decking surface.
Issues with Concrete, Cement, Mortar, or Stucco Dust	When working with cement, concrete, mortar, or stucco, protect the decking as much as possible in order to not get dust particles on the decking surface. These particles, once they get hot or wet, can cause a reaction on the decking surface and are very difficult to remove. If particles get on the decking surface, Trex recommends using Sakrete™ Concrete Dissolver (www.sakrete.com/products/concrete-dissolver). BE SURE TO FOLLOW MANUFACTURER'S INSTRUCTIONS.
Hard Water Staining	Hard water is water with a high amount of mineral deposits like lime, silica and calcium. When the water dries, deposits are left behind, leaving unsightly spots on surfaces. This is not a defect of Trex products but an issue with the water itself. Generally, these deposits can be cleaned with white vinegar on decking surfaces or with the use of Magic Eraser® on railing surfaces. Rinsing is required so care should be taken to not use hard water for this purpose. If hard water must be used, dry with a cloth or use a blower to dry surfaces. In some cases a deck brightener product may also be used to help clean hard water stains.
Chalk Lines	Most colored chinks are permanent and may discolor the surface. Use only Irwin Strait-Line® Dust-Off Marking Chalk (purple), available at Irwin.com .
Tannins Due to Debris	Remove all debris from the deck using a hose or broom. Once the deck surface is dry, apply a deck "brightener"*** to the deck as directed by the manufacturer. Deck Brighteners contain oxalic acid, which will also remove tannins.
Ice and Snow	A plastic shovel may be used to remove snow from the deck. Use calcium chloride or rock salt to melt the snow and ice from the deck surface.
Oil, Grease, and Food	All food spills should be removed as soon as possible. The surface must be cleaned within seven days to maintain the stain warranty. To remove, spray off with a hose and use warm, soapy water and a soft bristle brush to remove spills from the embossing pattern.
Mold and Mildew	If debris such as pollen and dirt are allowed to remain on the deck surface, mold can feed on the biofilm. Using a hose and warm, soapy water with a soft bristle brush is recommended to remove the food source and mold.



TREX TRANSCEND®, TREX ENHANCE®, AND TREX SELECT® CARE AND CLEANING GUIDE

PROBLEM	SOLUTION
Maintaining Transcend and Select Railing	Never use acetone or other solvents on Trex Transcend or Select railing to maintain the beauty of the surface. For color transfer issues (from attachment of baluster spacer), use Mr. Clean® Magic Eraser® Original or Plexus® Plastic Cleaner to help remove this. For small surface scratches, marks, or scuffs, use Dupli-Color Scratch Seal™ Clear Sealer Pen.
Trex and Static Electricity	<p>While this is not common, static electricity can occur on walking surfaces in dry climates or in areas where dry winds and dust-borne particles lay on the decking surfaces. Static electricity can build up on occupants walking across any composite decking surface, including Trex, then produce a small static shock if they touch a grounded metal surface such as railing, door, etc.</p> <p>This condition can be decreased greatly with the use of a product call ACL Staticide®. Two products tested were General Purpose Staticide® and Heavy Duty Staticide®. Both are effective in greatly reducing static electricity on Trex decking surfaces. Apply full strength using a mop on a dry decking surface, and allow to dry; no rinsing or diluting needed. Products are non-toxic, non-flammable, non-staining (will not change the color of decking surface), completely biodegradable and safe to use. Product is water-based and may require a second application after rain or other weather conditions. Over a period of time, the effect of static will dissipate naturally on the decking surface.</p> <p>See link for more information on product: http://www.aclstaticide.com/antistatic_coatings.html</p>
Rubber Mats	Use caution when using rubber-backed mats (i.e. welcome mats, etc.) as these may contain substances that can sometimes discolor or lighten the decking surface.
Curving Trex Decking	Trex recommends the use of the Trex® CustomCurve® to properly curve decking products. Note that Trex Enhance decking cannot be curved.
Job Site Storage	Store decking on a flat level surface and ALWAYS use proper supports (dunnage). DO NOT store directly on the ground. When stacking decking bundles, supports (dunnage) should start approximately 8-in (203 mm) from each end and be spaced approximately 2-ft (0.61m) on center. In addition, supports (dunnage) should line up vertically/perpendicular to the decking product. Adjust support blocks (dunnage) accordingly if bundles are loose. For Select decking, Enhance decking, and 1x12 and 1x8 products, the maximum stack height is 12 bundles. For all other decking products maximum stack height is 14 bundles (IMPORTANT TO NOTE THAT PROPER DUNNAGE SPACING MUST BE IN PLACE FOR THESE HEIGHTS). When stacking multiple bundles, ensure that dunnage lines up vertically down through each stack. ALWAYS cover decking products on site until ready to be installed.

*Use of a pressure washer greater than 3100 psi could damage the boards and void the warranty.

**Use of products containing bleach or acid can lighten the surface of Trex. Use in an inconspicuous area to determine whether you like the effect. Neither product will affect the structural integrity of Trex.

Mr. Clean® and Magic Eraser® are registered trademarks of The Proctor and Gamble Company.

Plexus Plastic Cleaner is a registered trademark of BTI Chemical Company Inc.

Scratch Seal™ Clear Sealer Pen is a registered trademark of Dupli-Color Products Company.

Sakrete™ is a trademark of Oldcastle APG, a CRH Company.

Strait-Line® is a registered trademark of Irwin Industrial Tool Company.

NOTES:

- » Refer to www.trex.com to view a general care and cleaning video for Transcend, Enhance, and Select decking.
- » Refer to www.trex.com for a care and cleaning guide for Trex Early-Generation Composite and PVC Decking.



TREX SIGNATURE® RAILING CARE AND CLEANING GUIDE

Maintaining the appearance of your Trex Signature railing is important. The occasional wash is recommended as over time your Trex Signature railing may show signs of weathering as a result of exposure to the elements. The frequency of cleaning will depend on the environment and exposure to various types of elements.

For installations where the atmosphere is influenced by bodies of salt water or other contaminant conditions, cleaning is required every 6 to 9 months. Failure to adhere to the required cleaning guidelines will void the Trex Limited Warranty with respect to any condition resulting from such failure. For purposes of any warranty claim, you should retain documentation of the cleaning date, cleaning method used, brand and amount of chemical used, and invoice from cleaning company (or a receipt for chemicals used).

Regular cleaning may minimize the effects of weathering and remove dirt, grime and other build-up. The best method of maintaining the appearance of your Trex Signature railing is to occasionally wash it using a solution of warm water and a non-abrasive, pH neutral detergent solution. The railing surface should be thoroughly rinsed after cleaning to remove all residues. Use a soft white cloth, sponge or a soft bristle brush.

DO NOT clean Trex Signature railing with solvents such as thinners or solutions containing chlorinated hydrocarbons, esters or ketones.

The following cleaners are recommended for cleaning Trex Signature railing:

- » Formula 409® Cleaner Degreaser/Disinfectant*
- » Spray Nine® Cleaner/Disinfectant**
- » Simple Green® All Purpose Cleaner***
- » Fantastik® All Purpose Cleaner****
- » Windex® Cleaner*****

** Formula 409® Cleaner Degreaser/Disinfectant is a trademark of Clorox Company.*

*** Spray Nine® All Purpose Cleaner/Disinfectant is a trademark of Illinois Tool Works Inc.*

**** Simple Green® All Purpose Cleaner is a trademark of Sunshine Makers Inc.*

***** Fantastik® All Purpose Cleaner is a trademark of SC Johnson & Son Inc.*

****** Windex® is a trademark of SC Johnson & Son Inc.*



PLANNING AHEAD

PLANNING AHEAD

Trex Decking:

- » When installing any Trex decking product, especially Trex Transcend Tropicals, it is a good idea to mix and match all of the boards on the job site prior to installation to ensure an appealing mix of light and dark tones.
- » **DO NOT** combine Trex Select decking with other Trex decking products. Trex Select boards are thinner than Transcend and Enhance boards.
- » For added protection to wood framing, use Trex Protect® Joist and Beam Tape on the top of joists, rim joists, and ledger boards to help prevent rot and wood decay. Refer to trexprotect.com for more details.

Railing (Including ADA Handrail):

- » First, pick the railing style you want.
- » Calculate your spanning based on the railing you chose.
- » Determine the number of balusters you will need based on the railing you chose.

NOTE: For post placement on stairs, it is VERY IMPORTANT to plan your post spacing based on the length of the rail and angle of the stairs. For nominal 6' and 8' stair rail lengths, stair post spans (measured horizontally) will be less than 6' or 8' due to the angle of the stairs.

NOTE: Trex Transcend and Select railings are made to be installed at maximum of 6' (1.83 m) or 8' (2.44 m) on center (depending upon type of railing you choose). Those railings are not true 6' (72") or 8' (96") in length. Trex Signature railing and Rod Rail are made to be installed at maximum 6' or 8' CLEAR SPAN BETWEEN POSTS.

- » Determine post locations prior to installing any decking. In most cases, posts are usually installed before decking is installed.
- » Confirm with your local building official if ADA Handrail is required, and if so plan spanning for posts accordingly to allow for attachment of Trex ADA Handrail. ADA Handrail requires a span of 6' OC for posts.
- » Grill placement: A good recommendation to help prevent damage to your railing is to not have a grill too close to your railing. Allow for ample airspace, (18"-30" is recommended - refer to grill manufacturer for additional details), between the back/sides of your grill to help prevent charring or staining to the railing.

See pages 56-78 for Transcend railing installation, pages 79-129 for Trex Signature railing installation, pages 130-154 for Rod Rail installation, pages 155-161 for Glass railing installation, pages 162-189 for Mesh railing installation, pages 192-209 for Select railing installation, and pages 210-212 for ADA Handrail installation.

Trex Lighting:

- » Plan locations of lights, power supply, timer, and dimmer. These should be accessible for service if necessary.
- » Install wiring before decking and railing have been installed.
- » **DO NOT** run wires between joists and deck boards.

See pages 13-21 for Trex® OutdoorLighting™ installation.

Trex® RainEscape® Deck Drainage System:

- » Plan ahead for deck layout to allow for proper placement of Trex RainEscape within the joist system.
- » Make sure joists are straight and square.

See www.trex.com for more information on Trex RainEscape recommendations and installation. Trex RainEscape is manufactured and distributed by IBP LLC, under a trademark license with Trex Company, Inc.

Installing Hot Tubs, Planters, and Seating:

- » Plan ahead proper joist spanning if required (this is especially important if installing a hot tub).
- » Refer to page 29 for Trex Decking Span Chart for specific loads.

Call 1-800-BUY-TREX for detailed questions.

PLANNING AHEAD/CONTINUED

Installing Fireplaces and/or Fire Pits With Trex Decking:



- » Determine if fire will be gas or wood burning. (NOTE: Most fire pits shown in Trex images are gas burning.)
- » For gas, the fire pit is installed by cutting around the Trex decking. **It is not to be installed on top of Trex decking.** A fire-resistant material is installed under the fire pit and a protective “wall” made from stone or other fire-resistant material is installed to hold fire pit in place and also protect the decking from heat.
- » For wood, fire pits are not recommended on top of Trex decking unless using a product called DeckProtect®. Wood-burning fire pits can damage the decking due to extreme heat from the bottom of the fire pit and/or burning embers “shooting” onto the decking. DeckProtect® was tested on all Trex decking and there were no issues with burning of the decking surface when placed directly under a standard size portable fire pit along with the accompanying rack (NOTE: Rack is not available for all sizes, so check with manufacturer first for verification). Trex does recommend that the DeckProtect® padding/rack be moved from time to time for general cleaning underneath. It should be noted that even when using DeckProtect®, burning embers could “shoot” beyond the protective mat and burn the deck.

For more information about this product, please visit their website at www.deckprotect.net or call 1-800-BUY-TREX. DeckProtect® is a registered trademark of Infinite Heat Solutions.

Installing a Pergola on Trex Decking:

- » Keep in mind if you are planning to install a Trex® Pergola™ on your deck, you will need access to the underside of the deck. Trex Pergola mounts with a 10” x 10” (254 mm x 254 mm) aluminum plate on the underside of the deck, creating a clamping effect on both the top and bottom of the deck for maximum strength. If installed, water barriers and any under deck coverings will have to be removed to properly install the pergola posts.

- » You need to consider the location of your pergola posts with respect to joists. However, you do not have to mount your plates between joists. It is possible to place blocks on the bottom of the joists and mount the Trex Pergola brackets through the blocks.



Trex® Pergola™ products are manufactured and sold by Home & Leisure, Inc., d/b/a/ Structureworks under a Trademark License Agreement with Trex Company, Inc. A 25-year Limited Warranty is provided by manufacturer.

Installing Trex® Spiral Stairs™:

- » Refer to www.trexspiralstairs.com for detailed information on how to plan and install Trex Spiral Stairs.

Trex® Spiral Stairs™ are manufactured and sold by M. Cohen and Sons, Inc., d/b/a The Iron Shop, under a Trademark License Agreement with Trex Company, Inc. A 25-year Limited Warranty is provided by manufacturer.

Installing Trex® Outdoor Kitchens™:

- » Refer to trex-outdoorkitchens.com for detailed information on how to install Trex Outdoor Kitchen products.

Trex® Outdoor Kitchens™ is manufactured and sold by CT Acquisitions LLC., under a Trademark Agreement with Trex Company, Inc. A Limited Warranty is provided by the manufacturer.

NOTE: You can always reference the Design Tools Section on www.trex.com for additional planning ahead aids.

LIGHTING

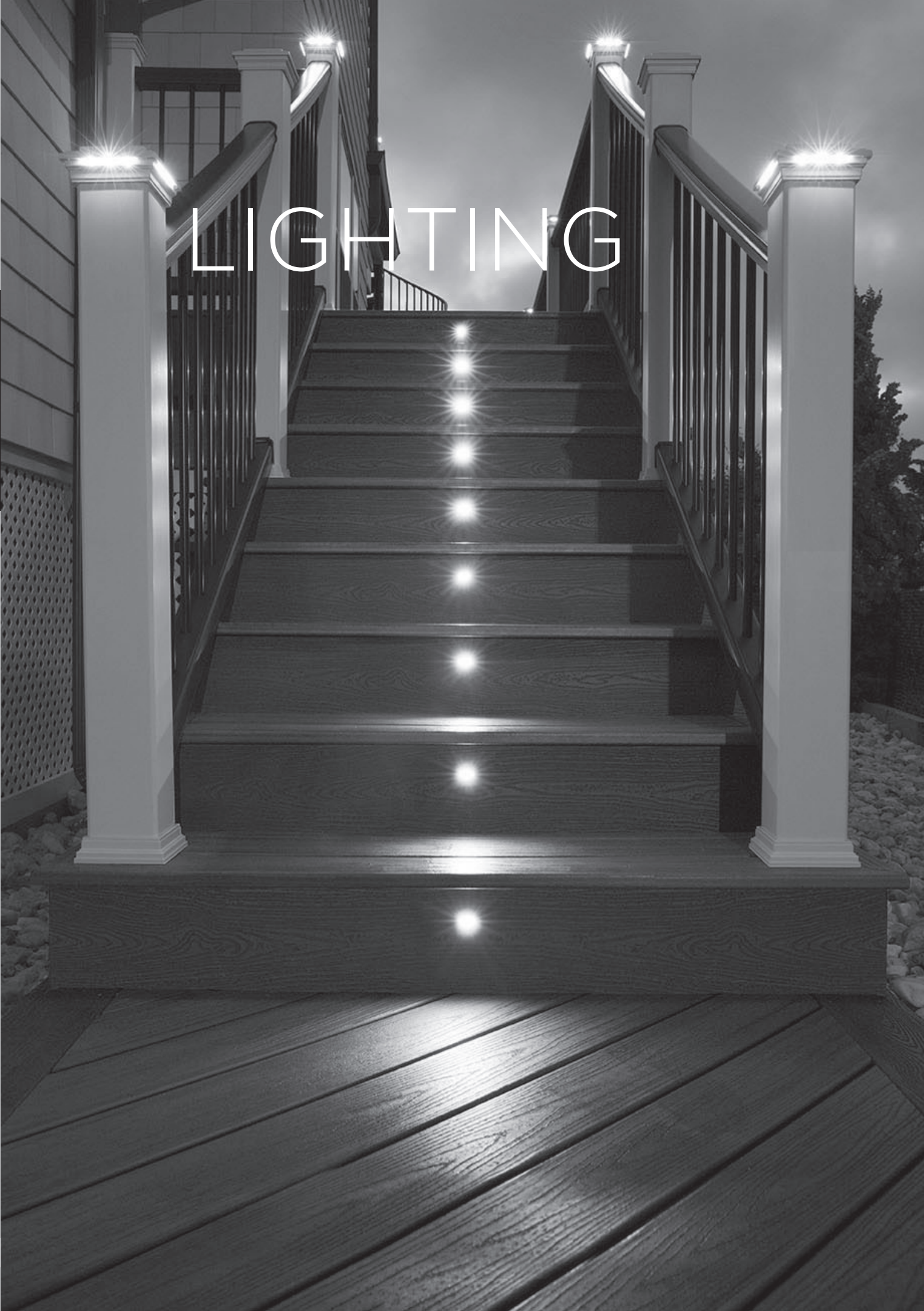

TREX® OUTDOOR LIGHTING™

COMPONENT & DESCRIPTION	ITEM NUMBER
<p>Flat Post Cap Light</p> <ul style="list-style-type: none"> » 4" x 4" LED Post Cap Light <i>[4.55 in x 4.55 in (115 mm x 115 mm) actual internal dimensions]</i> Use with Trex 4 in Composite Railing Posts » 5.5 ft (1.67 m) Male LightHub® Lead 	 <p>BKSQLEDCAP4X4C WTSQLEDCAP4X4C THSQLEDCAP4X4C VLSQLEDCAP4X4C GPSQLEDCAP4X4C RSSQLEDCAP4X4C</p>
<p>Aluminum Post Cap Light</p> <ul style="list-style-type: none"> » 2.5" x 2.5" LED Aluminum Post Cap Light <i>[2.6 in x 2.6 in (66 mm x 66 mm) actual internal dimensions]</i> Use with Trex 2.5 in Aluminum Railing Posts » 5.5 ft (1.67 m) Male LightHub Lead 	 <p>BKALCAPLED25 BZALCAPLED25 WTALCAPLED25</p>
<p>Aluminum Deck Rail Light</p> <ul style="list-style-type: none"> » LED Deck Rail Light <i>[2.75 in (69 mm) OD]</i> » 5.5 ft (1.67 m) Male LightHub Lead 	 <p>BKLAMPLEDC BZLAMPLEDC WTLAMPLEDC</p>
<p>Aluminum Wedge Deck Rail Light</p> <ul style="list-style-type: none"> » LED Wedge Deck Rail Light <i>[1.875 in wide x 3 in high (47 mm x 76 mm) actual dimensions]</i> Compatible with all Trex Railing Posts » 5.5 ft (1.67 m) Male LightHub Lead 	 <p>BKALPOSTLAMPLED BZALPOSTLAMPLED WTALPOSTLAMPLED</p>
<p>Aluminum Stair Riser Light</p> <ul style="list-style-type: none"> » 4 LED Riser Lights <i>[1.25 in (31 mm) OD]</i> » 5.5 ft (1.67 m) Male LightHub Lead 	 <p>BKRISERLED4PKC BZRISERLED4PKC WTRISERLED4PKC</p>
<p>Recessed Deck Light</p> <ul style="list-style-type: none"> » 4 LED Recessed Lights <i>[1 in (25 mm) OD]</i> » 5.5 ft (1.67 m) Male LightHub Lead 	 <p>RECESSLED4PKC</p>
<p>ACCESSORIES</p>	
<p>Transformer with Timer</p> <ul style="list-style-type: none"> » Output Voltage: 12VDC » Output Power: 100W or 30W » Output Current: 8.3A or 2.5A » Photo-Activated Timer » 20 ft (6.09 m) LightHub Wire Extension Cable <p>Multi-zone Transformer Adapter</p>	 <p>8.3A, 100W: DIMMABLE 83DLTRANSFORMERCC 2.5A, 30W: 25DLTRANSFORMER</p> <p>DL5TF5PLIT1PK</p>
<p>Dimmer</p> <ul style="list-style-type: none"> » Single Channel with Remote 	 <p>DLDIMMER</p>
<p>Forstner Bit</p> <ul style="list-style-type: none"> » Pack of 6 » 1 in (25 mm) 	 <p>DLBIT6PK</p>
<p>LightHub Accessories</p> <ul style="list-style-type: none"> » 3-Way Splitter » 6-Way Splitter » 5 ft (1.52 m) Wire Extension Cable » 10 ft (3.04 m) Wire Extension Cable » 20 ft (6.09 m) Wire Extension Cable » 40 ft (12.19 m) Wire Extension Cable » 60 ft (18.28 m) Wire Extension Cable » Female to Female Adapter 	 <p>DL3SPLIT6PK DL6SPLIT4PK DL5FTWR4PK DL10FTWR4PK DL20FTWR4PK DL40FTWR2PK DL60FTWR1PK DLFADAP6PK</p>

NOTE: Construction methods are always improving. Please refer to www.trex.com for the most up-to-date installation requirements.

HOW TO INSTALL TREX® DECKLIGHTING™

PARTS

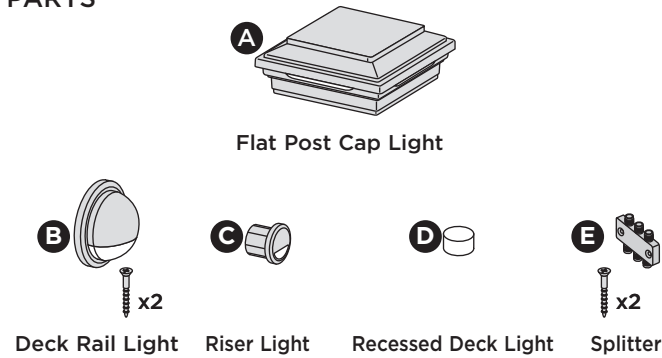

» 5ft, 10ft, 20ft, 40ft, and 60ft connection/extension wires sold separately (these are male-to-male connection wires).

WARNING:

- » **DO NOT INSTALL DECKLIGHTING IN CLOSE PROXIMITY TO POOLS OR HOT TUBS AS CHEMICALS FROM THE WATER CAN DAMAGE LIGHTING FIXTURES.**
- » **DO NOT INSTALL WIRING UNDER HEAVY WEIGHT OR LOAD AS THIS CAN DAMAGE WIRING.**

NOTE: Avoid railing brackets and locations for deck rail lights when running wires up posts.

NOTE: It is recommended to install wiring and splitters before decking and railing have been installed. **DO NOT** run wires between joists and deck boards.

Lighting and Wiring Overview

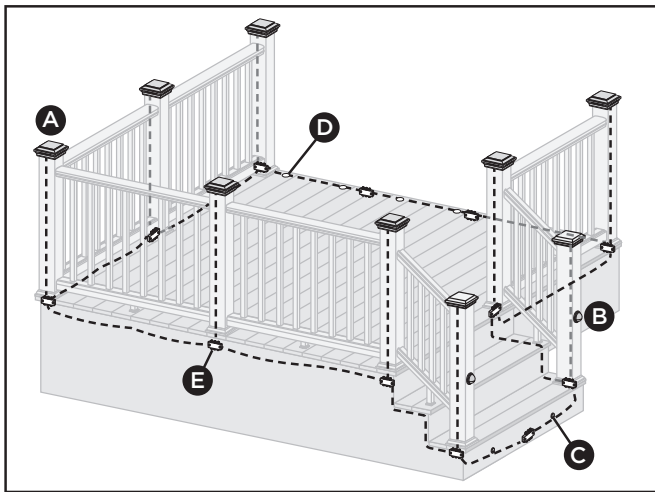

NOTE: All wiring and splitters are mounted to the inside of framing. Picture above is a general representation of where to place them.

TOOLS NEEDED

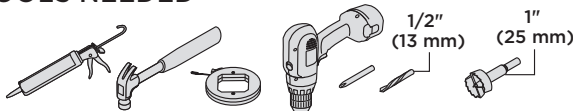

HELPFUL TIPS

- » Please note that Trex lighting operates on DC power. **NEVER** mix AC and DC fixtures on the same circuit. Doing so will result in extremely premature fixture failure and is not covered by the Trex limited warranty. **You must use a Trex transformer on all Trex lighting installations.**
- » **Never fully drive staples when securing wire. Wire should move under staple.**
- » **ALWAYS** protect any wire that is close to the ground with conduit or wire loom to prevent rodent damage.
- » Cap all unused female connections with caps provided or weather-resistant silicone to prevent water damage or corrosion.
- » Each dimmer operates on a separate remote.
- » It is recommended to have power source installed and turned on when installing lights to ensure all components work.
- » When installing wiring, avoid extreme angles, pressure, or tension on the wiring, as this can cause pinching of the wiring and create a lighting failure.



HOW TO INSTALL TREX® DECKLIGHTING™/CONTINUED

General Information

- » Refer to www.trex.com for instructional videos on how to install Trex DeckLighting.
- » USE TREX TRANSFORMER ONLY. Use of any other transformer voids warranty.

Transformer Capacity by Type		
Type of Light	8.3A Transformer (83 DL TRANSFORMER)	2.5A Transformer (2.5 DL TRANSFORMER)
Riser	79	27
Recessed	79	27
Post Cap	79	27
Deck Rail	79	27

Above listing is for maximum number of each individual light fixture type. For mixing and matching requirements, visit Trex.com and use the interactive Lighting Transformer Calculator (located on the Trex® Decklighting™ product page).

Planning

NOTE: When designing your deck, plan locations of lights, power supply, timer, and dimmer. These should be accessible for service. Installing a GFCI outlet is **REQUIRED** to help prevent damage to lighting from electrical surges.

1. The dimmer remote will work in a 30' (9 m) radius of the unit.
2. Dimmer should be installed in a dry location.
3. Timer must be installed vertically with receptacle facing downwards. Timer must be at least 1' (.305 m) from ground level when installed as per federal safety code height regulations. Timer must be in view of the sun to use the dusk/dawn feature.

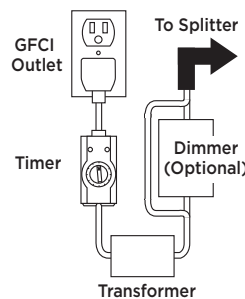

Installing Wiring

NOTES:

- » It is recommended to install wiring and splitters before decking and railing have been installed.
- » Use male-to-male connection wire (lengths vary) that will connect to each required splitter.

1. Wiring must be run under decking structure and behind stringers. **DO NOT** run wires between deck boards and joists. Staple to frame with cable staples at least 1/4" (6 mm) wide. **DO NOT** crush wire insulation with staples.

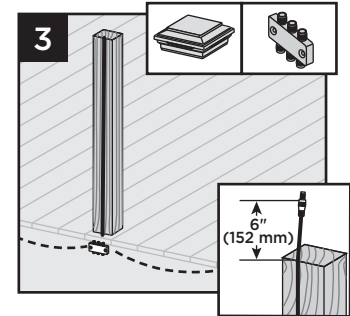
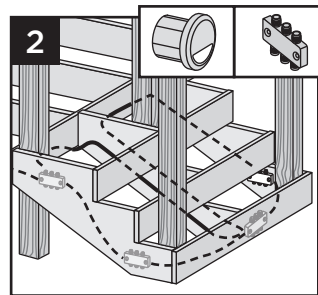
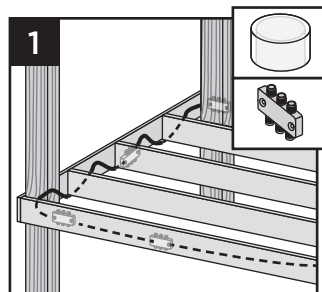

2. Wiring can be run under deck and behind risers. Staple to frame with cable staples at least 1/4" (6 mm) wide. **DO NOT** crush wire insulation with staples.
3. Remove 5' (1.52 m) lead wire that is connected to post cap and attach wire to post with male connection at top of post (female connection would be at bottom of post and connect into splitter). Avoid running wire on side of post where railing brackets or deck rail lights will be installed. Leave approximately 6" (152 mm) of lead at top to make connections. Staple to frame and posts with cable staples at least 1/4" (6 mm) wide. **DO NOT** crush wire insulation with staples.

Making Connections

1. Install splitters to inside of framing using hardware provided. Install at every post base where lighting is present and depending on spacing in between each riser and recessed light.

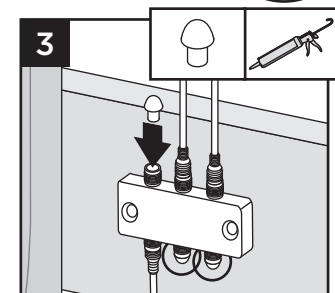
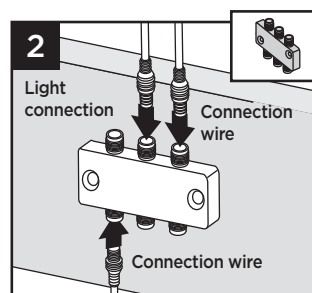
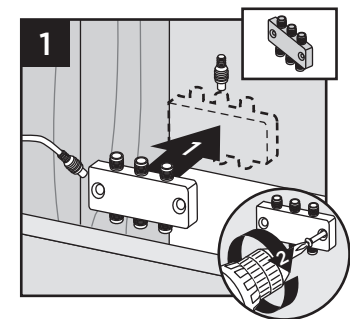

2. Attach male lead from lights to female connections on splitter. Also attach male-to-male connection wires in between each splitter. Continue until all wiring from lights are attached to splitters and connector wires are attached in between splitters.
3. Cap off all unused female connections on splitters using caps provided or weather-resistant silicone.



HOW TO INSTALL TREX® DECKLIGHTING™/CONTINUED

Timer Operation Instructions

1. Select the mode of operation:
 - » Dusk to Dawn
 - » 2-8 hours
 - » Always "ON"
 - » "OFF"

Program repeats daily. When power is flowing to lights, green light above POWER is on.

Installing Post Cap Lights

NOTE: Install post cap lights after the railing system, post sleeve skirt, and post sleeve have been installed.

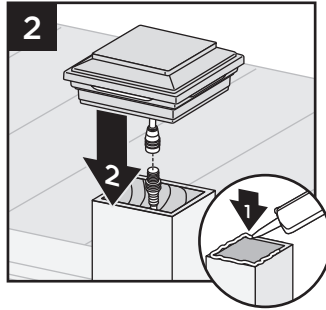
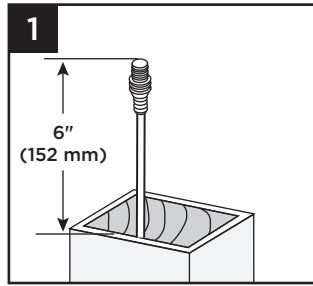

1. Connect male lead from wiring to female connector from cap. Also attach male-to-male connection wires in between each splitter. Continue until all wiring from lights is attached to splitters and connector wires are attached in between splitters. (See *Making Connections* section for details.)
2. After verifying wiring is correct by turning lights on, attach cap to top of post with silicone caulk.

Installing Deck Rail Lights

NOTE: Instructions shown below are for new deck installation and are shown **BEFORE** railing system has been installed.

1. Place post sleeve over pressure-treated post and mark desired height, centered on post sleeve for deck rail light location.

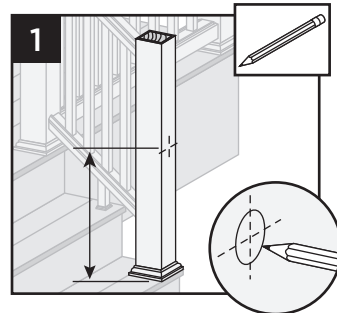

NOTE: If deck boards are not installed yet, place a deck board on framing to ensure post sleeve is at correct height.

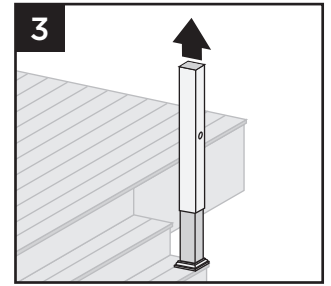
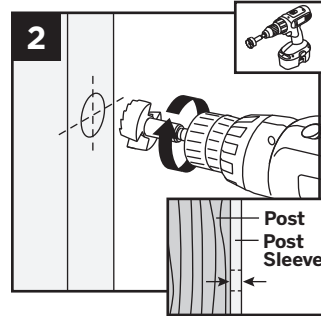

2. Drill a 1" (25 mm) hole through post sleeve. Drill deep enough to mark location on pressure-treated post.
3. Remove the post sleeve from the post.

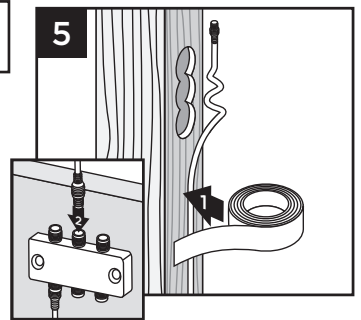
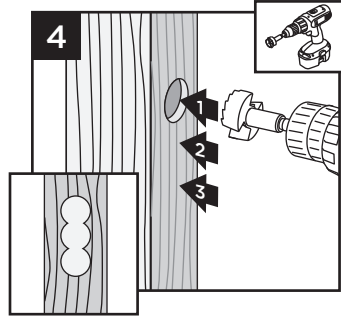

4. Drill out existing hole on pressure-treated post 3/4" (19 mm) deep. Drill two additional holes vertically below main hole—this will allow space for wiring after post sleeve is attached.
5. Leave enough slack at top of lead wire and attach lead wire to post using heavy duty tape. Attach lead wire to splitter under decking.

TIP: To hold lead wire in place at drilled-out location, use painters tape.

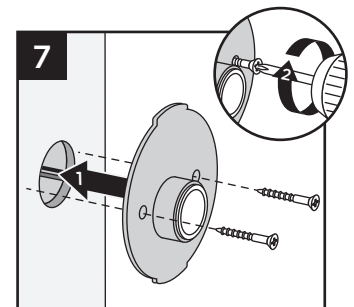
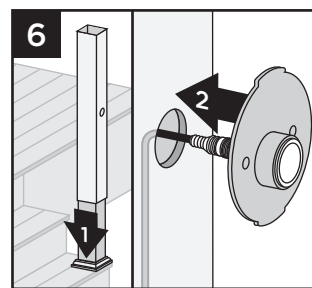

6. Slide post sleeve back over post. If using a post sleeve skirt, make sure to install the skirt first. Connect plug on deck rail light to lead wire and tuck wiring into previously drilled-out pockets on post.
7. Align holes for screws horizontally and attach fixture base to post with provided screws.

HOW TO INSTALL TREX® DECKLIGHTING™/CONTINUED

8. Line up polycarbonate lens with fixture housing. Twist onto fixture base. Continue until all wiring from lights is attached to splitters and connector wires are attached in between splitters. (See *Making Connections* section for details.)

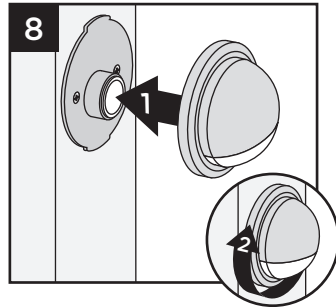

NOTE: If railing has already been installed, lead wires will need to be fished through the post sleeve to reach the desired location for the deck rail light. In some cases, if the provided lead wire does not fit (due to connector size), the wire connectors can be cut off and wire nuts can be used. Test lights with the power on. If lights that are wired with this method do not function, then switch the connector wires.

Installing Riser Lights

NOTE: Install riser lights after stairs and risers have been installed.

1. Mark locations for each light, generally 4" (102 mm) above tread. Consult local codes for lighting requirements.

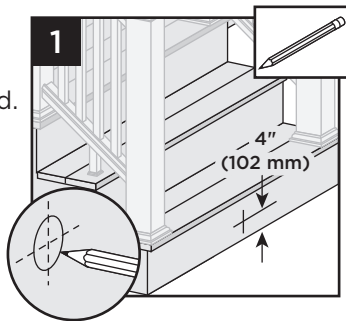

NOTE: If possible, avoid locations over stringers as holes will be more difficult to create.

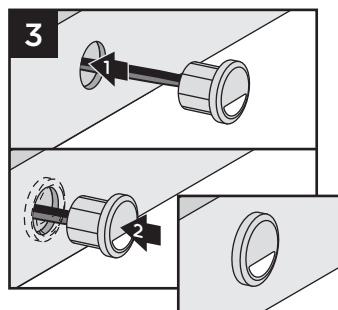
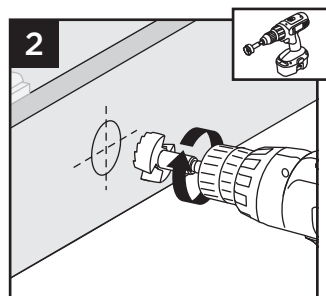

2. Drill a 1" (25 mm) diameter hole at least 1" (25 mm) deep into riser. If riser material is thicker than 1" (25 mm), use a 1/2" (13 mm) drill bit to create a passage for wires.
3. Thread wires through hole. Press light into hole, ensuring lens is horizontal. Make connections behind stairs from male lead wire from recessed light into female connection on splitter. Also attach male-to-male connection wires in between each splitter.

Continue until all wiring from lights is attached to splitters and connector wires are attached in between splitters. (See *Making Connections* section for details.)

NOTE: DO NOT install riser light or deck rail light into top or bottom rails or balusters.

Installing Recessed Deck Lights

NOTE: Install recessed deck lights after installing decking.

1. Mark locations for lights in deck boards.

NOTE: If possible, avoid locations over joists as holes will be more difficult to create.

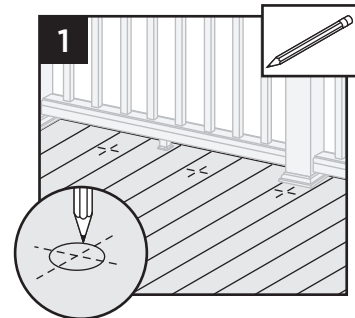

2. Drill a 1" (25 mm) diameter hole 3/4" (19 mm) deep into deck board. Hole cannot go all the way through deckboard or light will fall through. Make sure drill bit is perpendicular to board. Drill a 1/2" (13 mm) diameter hole in base of the first hole through deck board.

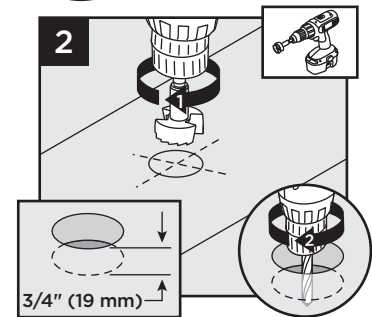

3. Thread wires through hole. **DO NOT** pull LED into hole by pulling on wires. This may damage wires or LED. Press light into hole until flush with surface. Make connections under deck from male lead wire from riser light into female connection on splitter. Also attach male-to-male connection wires in between each splitter. Continue until all wiring from lights is attached to splitters and connector wires are attached in between splitters. (See *Making Connections* section for details.)

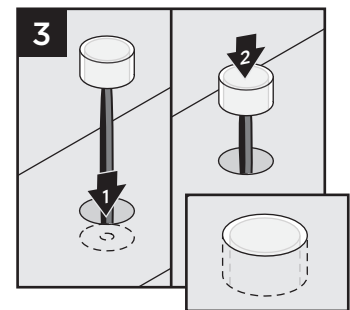

HOW TO PROGRAM DIMMER REMOTE

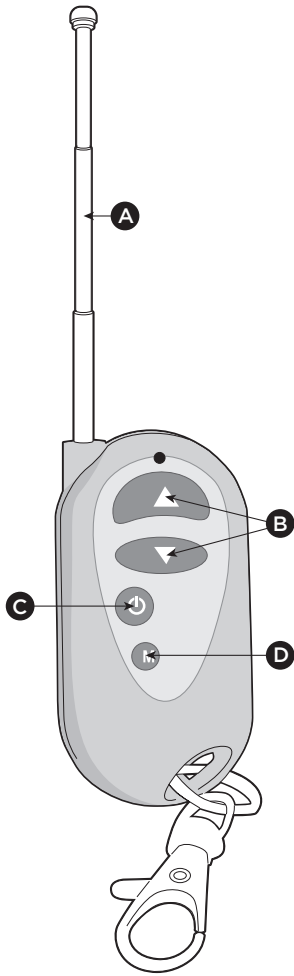

- A. **ALWAYS** keep antenna fully extended for maximum range.
- B. Up/Down arrows gradually dim or brighten lighting.
- C. On/Off button cycles lights ON/OFF.
- D. Mode button cycles through 3 preset dimming levels: High, Medium, Low, and Off.

NOTE: First, make sure the red light is illuminated on the remote. If there is no red light and the product is new, contact 1-800 BUY-TREX for a replacement. If the product is not new, the A27 battery is replaceable.

1. Install dimmer per instructions and make sure lights are ON and working properly.
2. Unplug the transformer to turn lights OFF.

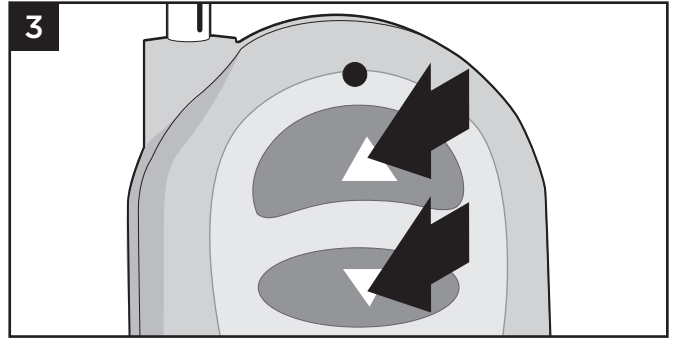
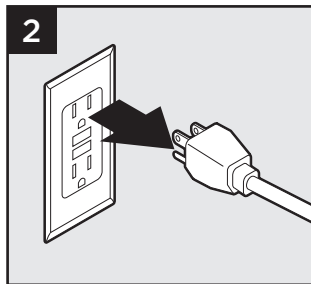

3. Press and hold both the up and down arrow on the dimmer remote simultaneously.

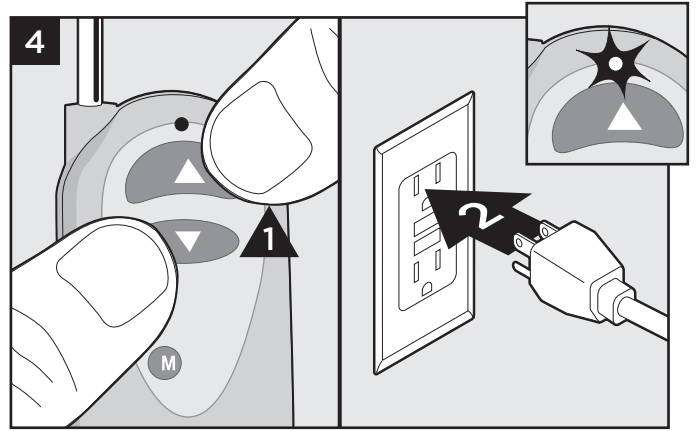

4. With the dimmer arrow buttons held down, plug the transformer back in. The lights should blink once to confirm programming.
5. Release the up and down arrows on the remote and test remote to confirm proper operation.

HOW TO INSTALL TREX SIGNATURE® CAP LIGHT

(can only be used on Trex Signature® posts)

PARTS



- » 5ft, 10ft, 20ft, 40ft, and 60ft connection/extension wires sold separately (these are male-to-male connection wires).

TOOLS NEEDED

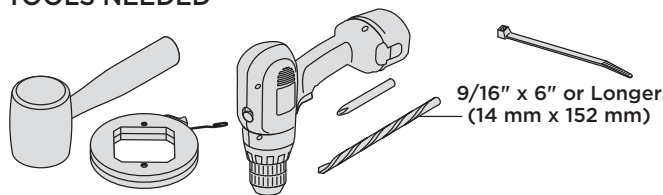

Helpful Tips

- » Leave slack in wire to make fixture terminations.
- » Post lamps work well at changes in levels of a deck—at the top or the bottom of the stairs, or in conjunction with post cap lights.
- » Splitters should be used at each post that has lights and depending on spacing in between each riser and recessed light.
- » Cap all unused female connections with caps provided or weather-resistant silicone to prevent water damage or corrosion.
- » The splitter is cross-linked so there is no specified plug for lights versus lead wires.
- » Leads attached to each light are approx. 5.5' (1.67 m) in length and have male terminals to plug into splitter.
- » Use a separate dimmer control for each light type for maximum control.
- » It is recommended to have power source on when installing lights to ensure all components work.

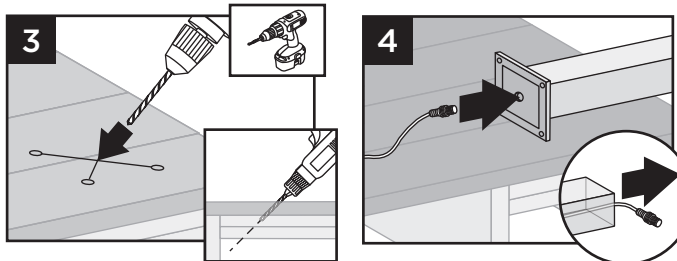

- Using a 9/16" (14 mm) x 6" (152 mm [or longer]) drill bit, drill a diagonal hole through the decking and blocking. Ensure that the angle will allow wire to not be pinched by support plate under blocking (if using Trex ALPOSTHWDECK mounting kit). (See *Making Connections* section for details.)
- Turn post upside down and fish 5' male-to-male wire (provided) through hole in baseplate.

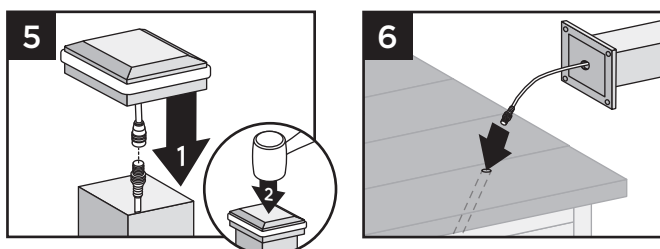

- Connect the female connector on the post cap light to this wire and, using a rubber mallet, gently tap the cap onto top of post until it is secure.
- Turn post over and carefully fish wire through hole created in Step 3 to underside of the deck. Ensure exit point of wire under blocking will not be pinched by ALPOSTHWDECK plate.
- Mount post per instructions.

Transformer Capacity by Type		
Type of Light	8.3A Transformer (83 DL TRANSFORMER)	2.5A Transformer (2.5 DL TRANSFORMER)
Signature Post Cap	59	29

Above listing is for maximum number of each individual light fixture type. For mixing and matching requirements, visit Trex.com and use the interactive Lighting Transformer Calculator (located on the Trex® Decklighting™ product page).

Installing Post Cap Lights

NOTE: Instructions shown below are for new deck installation and are shown **BEFORE** railing system has been installed.

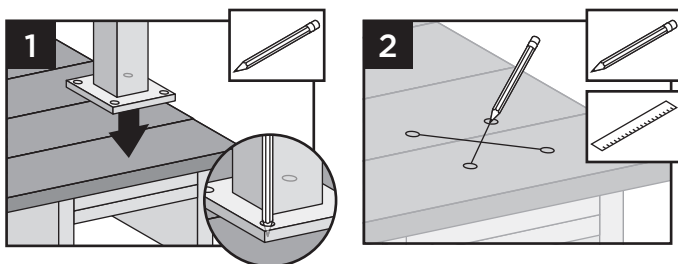

- Before attaching post to deck, locate placement of post and mark desired bolt locations.
- Using a straight edge, mark an "X" between the four bolt locations.

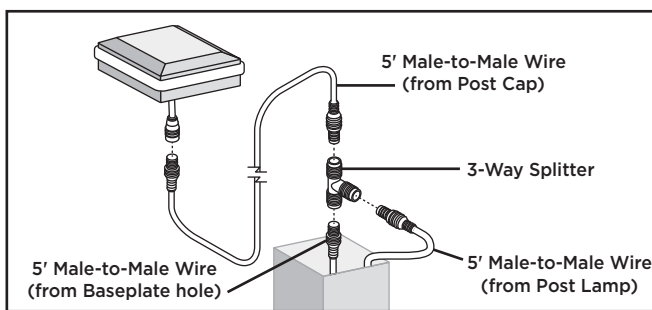

NOTE: If connecting a Trex Wedge Deck Rail Light as well, a 3-way adapter and extra 5' male-to-male wire (not provided) can be used inside the post so that only one wire must be run through the hole in the base of the post (and post blocking). This is optional.

HOW TO INSTALL TREX® WEDGE DECK RAIL LIGHT

PARTS

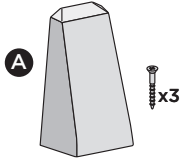

Wedge Deck Rail Light
(includes 5ft male-to-male wire)

- » 5ft, 10ft, 20ft, 40ft, and 60ft connection/extension wires sold separately (these are male-to-male connection wires).

TOOLS NEEDED

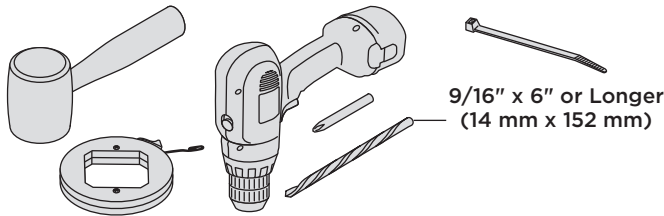

Helpful Tips

- » Leave slack in wire to make fixture terminations.
- » Deck rail lights work well at changes in levels of a deck—at the top or the bottom of the stairs, or in conjunction with post cap lights.
- » Splitters should be used at each post that has lights and depending on spacing in between each riser and recessed light.
- » Cap all unused female connections with caps provided or weather-resistant silicone to prevent water damage or corrosion.
- » The splitter is cross-linked so there is no specified plug for lights versus lead wires.
- » Leads attached to each light are approx. 5.5' (1.67 m) in length and have male terminals to plug into splitter.
- » Use a separate dimmer control for each light type for maximum control.
- » It is recommended to have power source on when installing lights to ensure all components work.

Transformer Capacity by Type

Type of Light	8.3A Transformer (83 DL TRANSFORMER)	2.5A Transformer (2.5 DL TRANSFORMER)
Signature Wedge Deck Rail Light	79	27

Above listing is for maximum number of each individual light fixture type. For mixing and matching requirements, visit Trex.com and use the interactive Lighting Transformer Calculator (located on the Trex® Decklighting™ product page).

Installing Post Lamps

NOTE: Instructions shown below are for new deck installation and are shown BEFORE railing system has been installed.

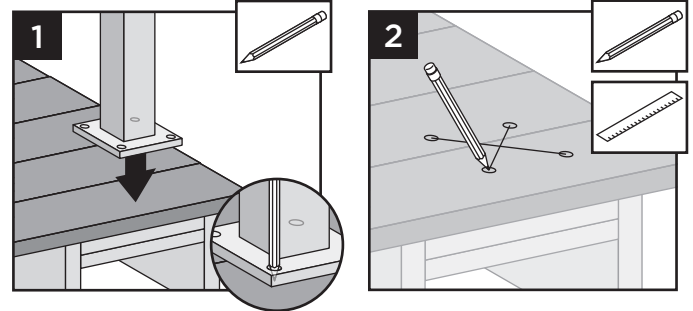

1. Before attaching post to deck, locate placement of post and mark desired bolt locations.
2. Using a straight edge, mark an "X" between the four bolt locations.

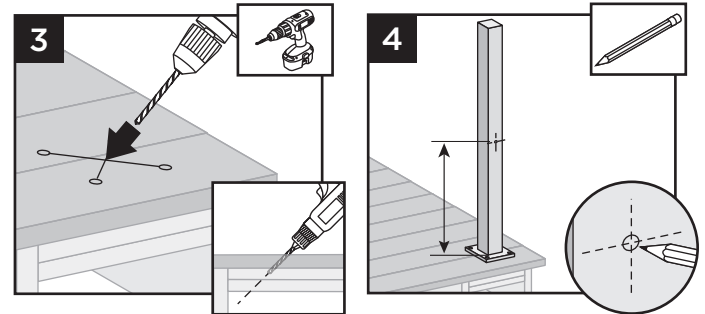

3. Using a 9/16" (14 mm) x 6" (152 mm [or longer]) drill bit, drill a diagonal hole through the decking and blocking. Ensure that the angle will allow wire to not be pinched by support plate under blocking (if using Trex ALPOSTHWDECK mounting kit).
4. Locate placement of post lamp. Mark entry point of the wire.
5. Drill 9/16" (14 mm) hole where wire will enter post.

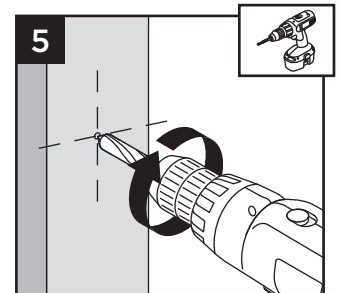

HOW TO INSTALL TREX® WEDGE DECK RAIL LIGHT/CONTINUED

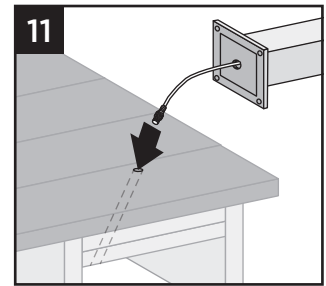
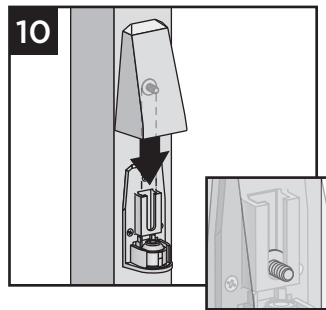
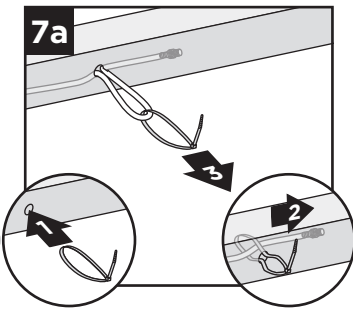
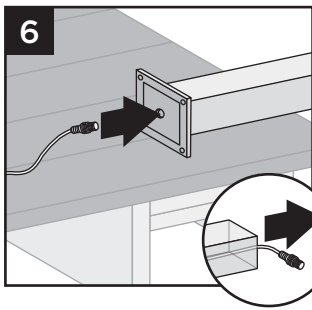

- 6. Turn post upside down and fish 5' male-to-male wire (provided) through hole in baseplate.
- 7a. If connecting a Wedge Deck Rail Light only, pull wire through hole.

TIP: Insert a zip-tie loop (or small grabber tool) through 9/16" (14 mm) hole. Fish wire through loop in zip-tie. Pull wire through hole with zip-tie.

- 7b. If connecting a Trex Signature post cap light as well, and using the 3-way splitter (see note after Step 12), simply run one wire through the hole created in Step 5 to the top of the post.

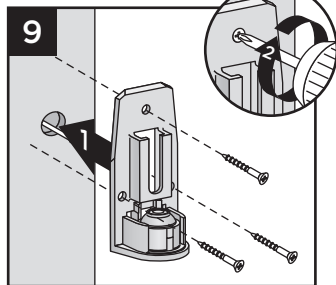
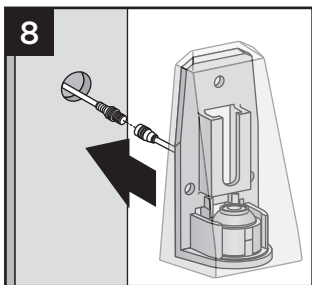
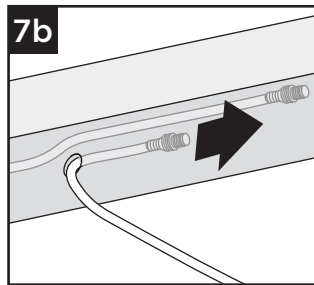

- 8. Connect male connector to female connector on light housing.
- 9. Place light and attach backing plate to post with three screws (provided).

- 10. Slide light cover down over backing plate, adjusting mounting screws as necessary to achieve a tight fit.
- 11. Turn post over and carefully fish wire through hole created in Step 3 to underside of the deck. Ensure exit point of wire under blocking will not be pinched by ALPOSTHWDECK plate.
- 12. Mount post per instructions.

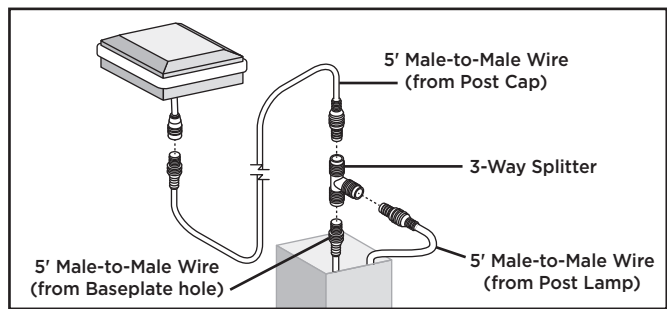

NOTE: If connecting a Trex Signature post cap light as well, a 3-way adapter and extra 5' male-to-male wire (not provided) can be used inside the post so that only one wire must be run through the hole in the base of the post (and post blocking). This is optional.



DECKING

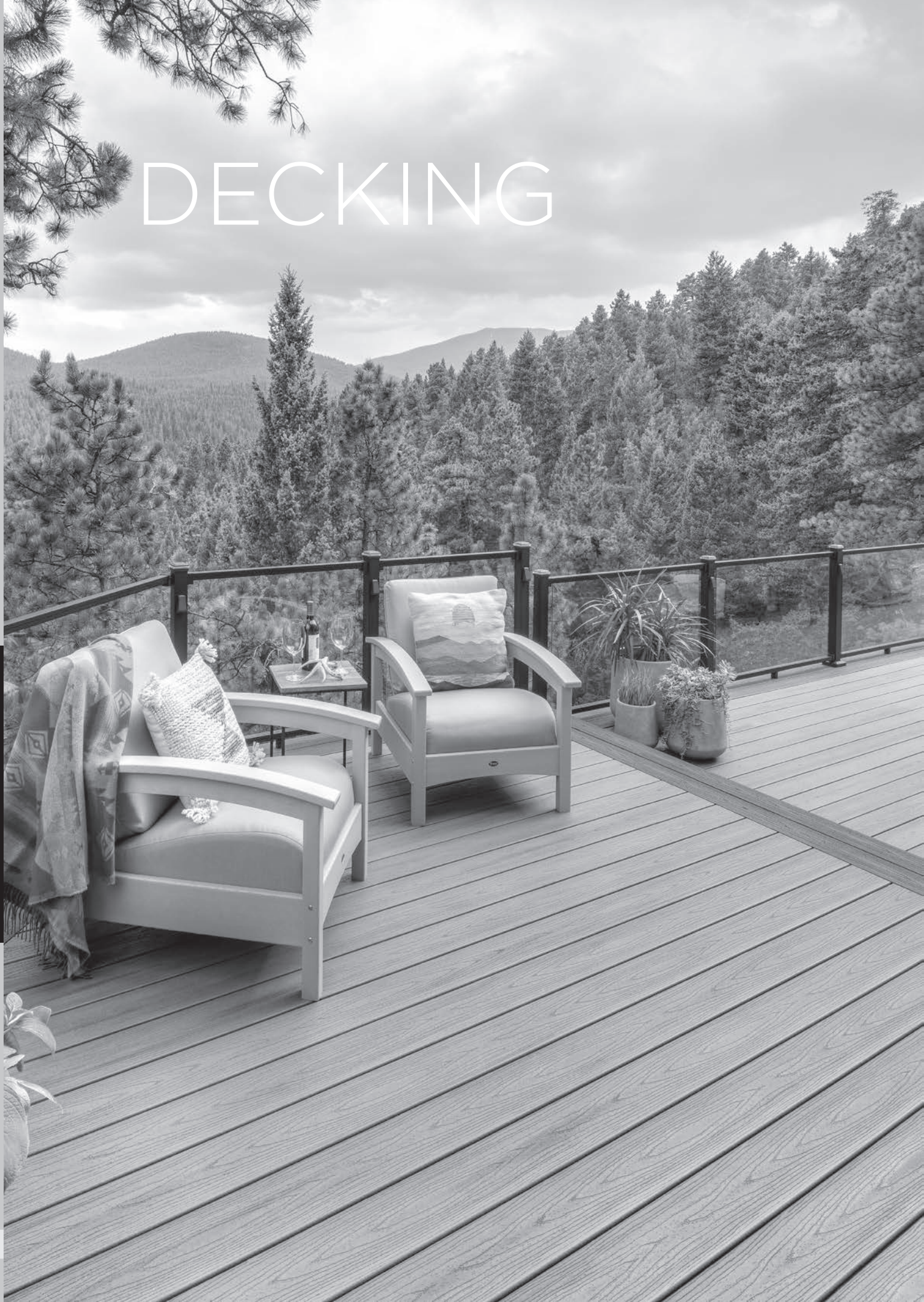

TREX® DECKING & FASCIA

PROFILE	DESCRIPTION	ITEM NUMBER	COLORS					
1" Square-Edge Board Actual dimensions: Transcend & Enhance: .94 in x 5.5 in x 12 ft / 16 ft / 20 ft (24 mm x 140 mm x 365 cm / 487 cm / 609 cm) Select: .82 in x 5.5 in x 12 ft / 16 ft / 20 ft (20 mm x 140 mm x 365 cm / 487 cm / 609 cm)	1 x 6 x 12' 1 x 6 x 16' 1 x 6 x 20' 1 x 6 x 12' 1 x 6 x 16' 1 x 6 x 20' 1 x 6 x 12' 1 x 6 x 16' 1 x 6 x 20' 1 x 6 x 12' 1 x 6 x 16' 1 x 6 x 20' 7/8 x 6 x 12' 7/8 x 6 x 16' 7/8 x 6 x 20'	Transcend Tropicals Transcend Tropicals Transcend Tropicals Transcend Earth Tones Transcend Earth Tones Transcend Earth Tones Enhance Basics Enhance Basics Enhance Basics Enhance Naturals Enhance Naturals Enhance Naturals Select Select Select	XX010612TS01 XX010616TS01 XX010620TS01 XX010612T2S01 XX010616T2S01 XX010620T2S01 XX010612E2S01 XX010616E2S01 XX010620E2S01 XX010612E2S01 XX010616E2S01 XX010620E2S01 XX010612SS01 XX010616SS01 XX010620SS01	IM, TT, HG, SR, LR GP, RS, VL CS, BD, SD FW, RH, TS, CB PG, WG, SD, WB, MB				
	1" Grooved-Edge Board Actual dimensions: Transcend & Enhance: .94 in x 5.5 in x 12 ft / 16 ft / 20 ft (24 mm x 140 mm x 365 cm / 487 cm / 609 cm) Select: .82 in x 5.5 in x 12 ft / 16 ft / 20 ft (20 mm x 140 mm x 365 cm / 487 cm / 609 cm)	1 x 6 x 12' 1 x 6 x 16' 1 x 6 x 20' 1 x 6 x 12' 1 x 6 x 16' 1 x 6 x 20' 1 x 6 x 12' 1 x 6 x 16' 1 x 6 x 20' 1 x 6 x 12' 1 x 6 x 16' 1 x 6 x 20' 7/8 x 6 x 12' 7/8 x 6 x 16' 7/8 x 6 x 20'	Transcend Tropicals Transcend Tropicals Transcend Tropicals Transcend Earth Tones Transcend Earth Tones Transcend Earth Tones Enhance Basics Enhance Basics Enhance Basics Enhance Naturals Enhance Naturals Enhance Naturals Select Select Select	XX010612TG01 XX010616TG01 XX010620TG01 XX010612T2G01 XX010616T2G01 XX010620T2G01 XX010612E2G01 XX010616E2G01 XX010620E2G01 XX010612E2G01 XX010616E2G01 XX010620E2G01 XX010612SG01 XX010616SG01 XX010620SG01	IM, TT, HG, SR, LR GP, RS, VL CS, BD, SD FW, RH, TS, CB PG, WG, SD, WB, MB			
		1" x 8" Fascia Actual dimensions: Transcend, Enhance, Select, Universal White: .56 in x 7.25 in x 12 ft (14 mm x 184 mm x 365 cm)	1 x 8 x 12' 1 x 8 x 12' 1 x 8 x 12' 1 x 8 x 12' 1 x 8 x 12' 1 x 8 x 12'	Transcend Tropicals Transcend Earth Tones Enhance Basics Enhance Naturals Select Universal White	XX010812TS01 XX010812T2S01 XX010812E2S01 XX010812E2S01 XX010812SS01 WW010812ES01	IM, TT, HG, SR, LR GP, RS, VL CS, BD, SD FW, RH, TS, CB PG, WG, SD, WB, MB WW		
			1" x 12" Fascia Actual dimensions: Transcend, Enhance, Select, Universal White: .56 in x 11.375 in x 12 ft (14 mm x 288 mm x 365 cm)	1 x 12 x 12' 1 x 12 x 12' 1 x 12 x 12' 1 x 12 x 12' 1 x 12 x 12' 1 x 12 x 12'	Transcend Tropicals Transcend Earth Tones Enhance Basics Enhance Naturals Select Universal White	XX011212TS01 XX011212T2S01 XX011212E2S01 XX011212E2S01 XX011212SS01 WW011212ES01	IM, TT, HG, SR, LR GP, RS, VL CS, BD, SD FW, RH, TS, CB PG, WG, SD, WB, MB WW	
				2" Square-Edge Board Actual dimensions: Transcend 2x4: 1.3 in x 3.4 in x 16 ft (33 mm x 86 mm x 487 cm) Transcend & Select 2x6: 1.3 in x 5.5 in x 12 ft / 16 ft / 20 ft (33 mm x 140 mm x 365 cm / 487 cm / 609 cm)	2 x 4 x 16' 2 x 6 x 12' 2 x 6 x 16' 2 x 6 x 20' 2 x 6 x 12' 2 x 6 x 16' 2 x 6 x 20'	Transcend Tropicals Transcend Tropicals Transcend Tropicals Transcend Tropicals Select Select Select	XX020416TS01 XX020612TS01 XX020616TS01 XX020620TS01 XX020612SS01 XX020616SS01 XX020620SS01	IM, TT, HG, SR, LR IM, TT, HG, SR, LR PG, SD, WB, MB

IM Island Mist	GP Gravel Path	SD Saddle	TS Toasted Sand	WW Wood Grain White
TT Tiki Torch	RS Rope Swing	WB Woodland Brown	CB Coastal Bluff	
HG Havana Gold	VL Vintage Lantern	MB Madeira	CS Clam Shell	
SR Spiced Rum	PG Pebble Grey	FW Foggy Wharf	BD Beach Dune	
LR Lava Rock	WG Winchester Grey	RH Rocky Harbor	SD Saddle	

TREX HIDEAWAY® HIDDEN FASTENING SYSTEM	DESCRIPTION	ITEM NUMBER
Universal Starter Clip	400 sq. ft. (37 sq. m) bag	UNIVSTARTCLIP
Universal Fastener (glass-filled nylon)	50 sq. ft. (4.6 sq. m) box 500 sq. ft. (46.5 sq. m) bucket	UNIVCONCLIP DA00002
Router Bit	Router Bit	ROUTBIT

NOTE: Construction methods are always improving. Please refer to www.trex.com for the most up-to-date installation requirements.

Decking and Fascia Recommended Fasteners

If any condition occurs which is attributable to the use of non-recommended fasteners, such condition shall not be covered under the Trex Limited Warranty.

		Transcend [®]	Enhance [®] (scalloped profile)	Select [®]	
RECOMMENDED FASTENERS	DECKING-HIDDEN FASTENERS				
	Trex Hideaway [®] Universal Hidden Fastener	X	X	X	
	TigerClaw [®] TC-G Hidden Fastener	X	X	X	
	Cortex [®] Concealed Fasteners*	X		X	
	Starborn [®] Pro Plug [®] System for PVC & Composite (Epoxy Coated & Stainless) (2" are approved for sleeper & roof top applications only)	X		X	
	Simpson Strong-Tie [®] Deck Drive [™] DCU Composite Screw & DCU Screw Plugs (Handdrive only & must also use Auto-Set Drive Bit)	X		X	
	DECKING-COMPOSITE SCREWS				
	FastenMaster [®] TrapEase 3 Ultimate Composite Deck Screw	X	X	X	
	Simpson Strong-Tie [®] Deck-Drive [™] DCU Composite Screw (Collated & Handdrive)	X	X	X	
	Quik Drive [®] Composi-Lok Deck Screw	X	X	X	
	SplitStop [™] Titan III Composite Screw	X	X	X	
	Starborn [®] Cap-Tor [®] xd Epoxy Coated & Headcote [®] Stainless (available collated for Muro CH7390 Driver**) (2" are approved for sleeper & roof top applications only)	X	X	X	
	Screw Products C-Deck Exterior Star Drive Composite Deck Screw	X	X	X	
	Phillips II Plus [®] Pozisquare	X	X	X	
Muro [®] T-Screw Torx Stainless Steel Screw - Collated (TX0212SFD or M-TX0300SEP)	X	X	X		
Kameleon [™] GRKFasteners [™]			X		

		Transcend	Enhance	Select	
RECOMMENDED FASTENERS	FASCIA**				
	Cortex [®] Hidden Fastening System for Fascia	X	X	X	
	Starborn [®] Pro Plug [®] System for Fascia - Epoxy Coated & Stainless	X	X	X	
	Starborn [®] Deckfast [®] Fascia System - Epoxy Coated & Headcote [®] Stainless	X	X	X	
	SplitStop [™] Fascia Screw	X	X	X	
	Simpson Strong-Tie [®] Fascia Board Screw	X	X	X	
	FastenMaster [®] TrapEase [®] Fascia Fastener	X	X	X	

NOTES:

- » Do not use any hidden fasteners that are plug based with Trex Enhance profiles with scalloped bottom.
- » 2-3/4" or 3" screws can be used with Trex 2x6 product.
- » Muro T-Screw M-TX0300SEP listed above is approved for 2x6 decking (can also be used with standard 1" (decking as listed above). This screw is collated and can be used with Muro Auto Feed Screw Gun FDVL41 Speed Driver. **(NOTE: THIS IS NOT A COLOR-MATCH SCREW.)**
- » All decking products are approved for use with Trex Hideaway Hidden Fasteners, thus all decking products can be routed according to our instructions.
- » Simpson Strong-Tie Deck Drive DCU Composite Screw in collated versions works with Quik Drive gun.
- » * Not for use with sleeper systems. Refer to FastenMaster[®] literature for more information. Also, these are approved with Trex 2x6 decking profiles.
- » ** Fascia system screws listed above **can only be used with composite fascia profiles**, and cannot be used with standard thickness decking boards used as fascia. Use stainless steel screws near water applications.
- » Trex recommends the use of two screws per joist.
- » All recommended screws are designed to be installed flush with decking surface. DO NOT countersink screws.
- » Use recommended stainless steel screws in any areas near bodies of saltwater.

FastenMaster[®] TrapEase[®] 3 and Cortex[®] are registered trademarks of OMG, Inc.

Quik Drive[®] is a registered trademark and Composi-Lok[™] is a trademark of Simpson Strong-Tie Company, Inc.

DeckFast[®] Cap-Tor[®] xd and HeadCote[®] Cap-Tor[®] xd are registered trademarks of Starborn Industries Inc.

C-Deck Exterior Star Deck Composite Deck Screw is a product of Screw Products Inc.

Phillips II Plus[®] is a registered trademark of Phillips Fasteners LLC.

SplitStop[™] screws are a registered trademark of Titan Metal Werks, Inc.

Minimum Fastener Size		
SCREWS		
Profile	Length	No.
1x6	2-1/2" or 2-3/4"	#8, #10
2x6	2-3/4" or 3"	#8, #10

Trex® Fascia Installation Recommendations

Trex Fascia utilized around the perimeter of a deck must be gapped with the same requirements as Trex decking to allow for air flow and expansion/contraction of the fascia.

TIPS:

- » 10" rim joists (represented below unless noted) allow for an easier and more aesthetically pleasing installation.

When Using Approved Fascia Fasteners:

NOTE: The fasteners listed below can only be used with 1x8 or 1x12 fascia product, and cannot be used with decking product that is being used as fascia trim or stair risers.

See previous page for Trex-recommended Fascia fasteners.

Always refer to manufacturing instructions first for installation methods. If instructions are not specific, refer to the diagram below. Always remember to gap fascia properly. A secondary glue is not required when using these fasteners.

NOTE: Instructions below reflect the use of Trex-recommended fascia fasteners. If using deck boards as fascia, refer to the recommendations in next column on this page.

If Using Other Fasteners and/or Using Decking Product in Fascia/Stair Riser Applications:

While Trex prefers the previous methods of attachment, as these are the very best options, there are also other recommendations that can be followed for fascia or deck boards being used for fascia. Use three Trex recommended composite decking screws every 12". *ALWAYS refer to manufacturer instructions to ensure that recommended screws can be used for fascia applications.* The top screw should be placed 1" from the top of the **rim joist**, the second screw in the center of the rim joist, and the third screw 1" from the bottom of the **rim joist**.

****IN ADDITION**, also use a weather-resistant, construction-grade adhesive (adhesives that work with wood will work with Trex products) as a **SECONDARY** fastener when attaching fascia. *Remember to wipe away any excess before it dries or is allowed to drip on other Trex surfaces.*

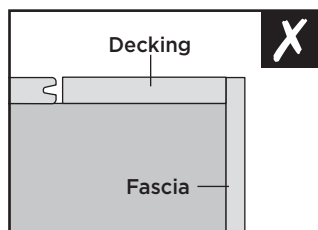
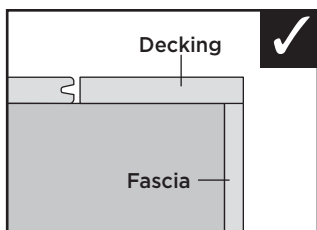
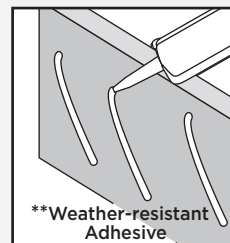

Install fascia **UNDER** decking edges/ends. This will provide protection to the fascia/framing seam as well as optimize the aesthetics of the installation.

Do Not install fascia in the method shown here. The fascia board must be attached fully to the rim joist and cannot run parallel to the decking surface.

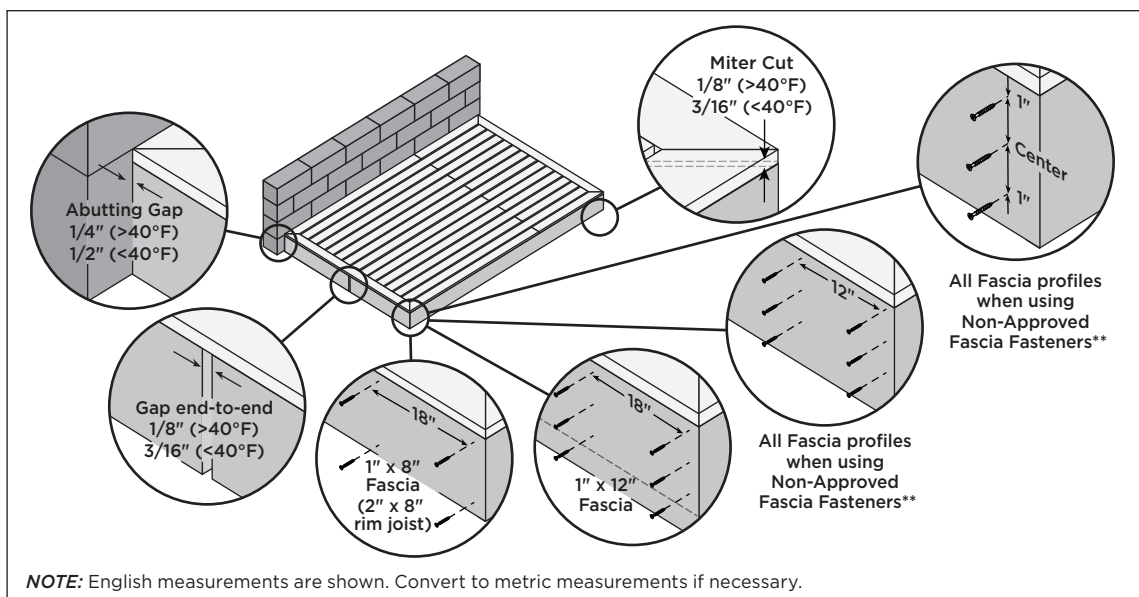

NOTE: Construction methods are always improving. Please refer to www.trex.com for the most up-to-date installation requirements.

Framing and Fastening Tips

Fastening Tip for Trex Transcend, Trex Enhance, and Trex Select

NOTE: When using pneumatic or battery-operated equipment, adjust the pressure so that you only shoot the head of the screw to be flush with the board's cap. **DO NOT** shoot the fastener head completely through the shell.

Trex Products Near Low-E Windows

Low-E glass reflects more sunlight. It has been observed that the extra reflectivity, combined with any concavity in the glass, can act like a concave mirror. This mirror effect concentrates sunlight onto outdoor objects, including that of decking and railing. This can result in an extreme amount of heat concentrated on areas of the decking surface. This can sometimes char the decking surface or cause the decking to slightly bow.

Clean Cut Boards

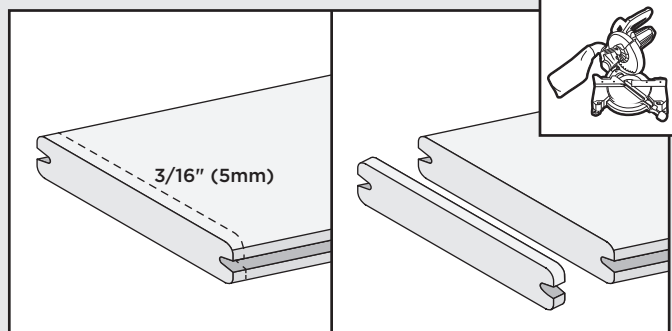

It is recommended that boards be clean cut on both ends a minimum of 3/16" (5mm).

Composite decking is a great alternative to traditional wood decking. When building your deck and railing, it is recommended that code-approved structural material be used as the framing and joists. Check your local building codes for restrictions. Trex decking cannot be used for structural applications. **Do not** attach Trex decking directly to any solid surface or watertight system.

In most cases, install fasteners at a 90° angle (perpendicular to the board).

At board ends on the deck's edge, you can install screws placed perpendicularly at the recommended distance, at minimum of 1" (25mm) from the board end and edge, without splitting the board.

For butt joints, where boards meet over a single joist, add a 2" x 4" "nailer" board at the butt joint. This allows screw-in at 90 degrees and allows fasteners to be used at end of each board.

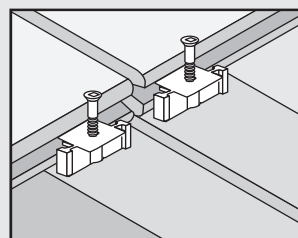
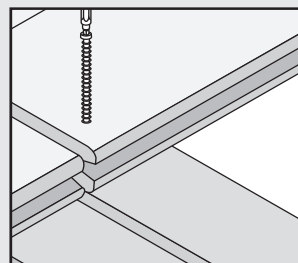
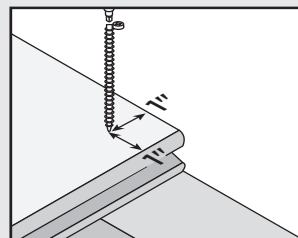

Dock Applications

Trex decking contains no materials that will harm marine life and is safe for the environment. As long as dock is in intermittent contact with water, i.e., splashing and not in continuous direct contact with water, the durability of the Trex decking should not be affected.

For docks, a 3/8" (10mm) width-to-width gap between boards is recommended to allow for increased drainage due to increased contact with water. In addition, stainless steel fasteners should be used. If there is sufficient contact between the dock and gasoline, grounding of the dock is also recommended.

Special Patterns

When planning a unique pattern, you will need to adjust the framing to support the surface pattern. Many decks are designed to take advantage of angles, as shown below.

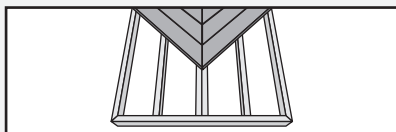

Herringbone Pattern

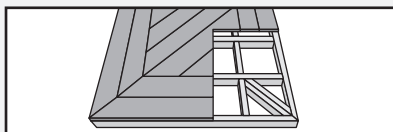

Picture Frame Pattern

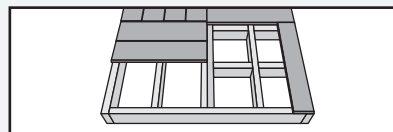

Tile Pattern

Rooftop and Sleeper Deck Systems – Pressure-Treated Framing

A sleeper system is a substructure between a solid surface and Trex decking. Drainage, access, and airflow are critical. Water must be able to flow through and away from the deck. For repairs and removal of debris, joist system access may be necessary.

NOTE: English measurements are shown.
Convert to metric measurements if necessary.

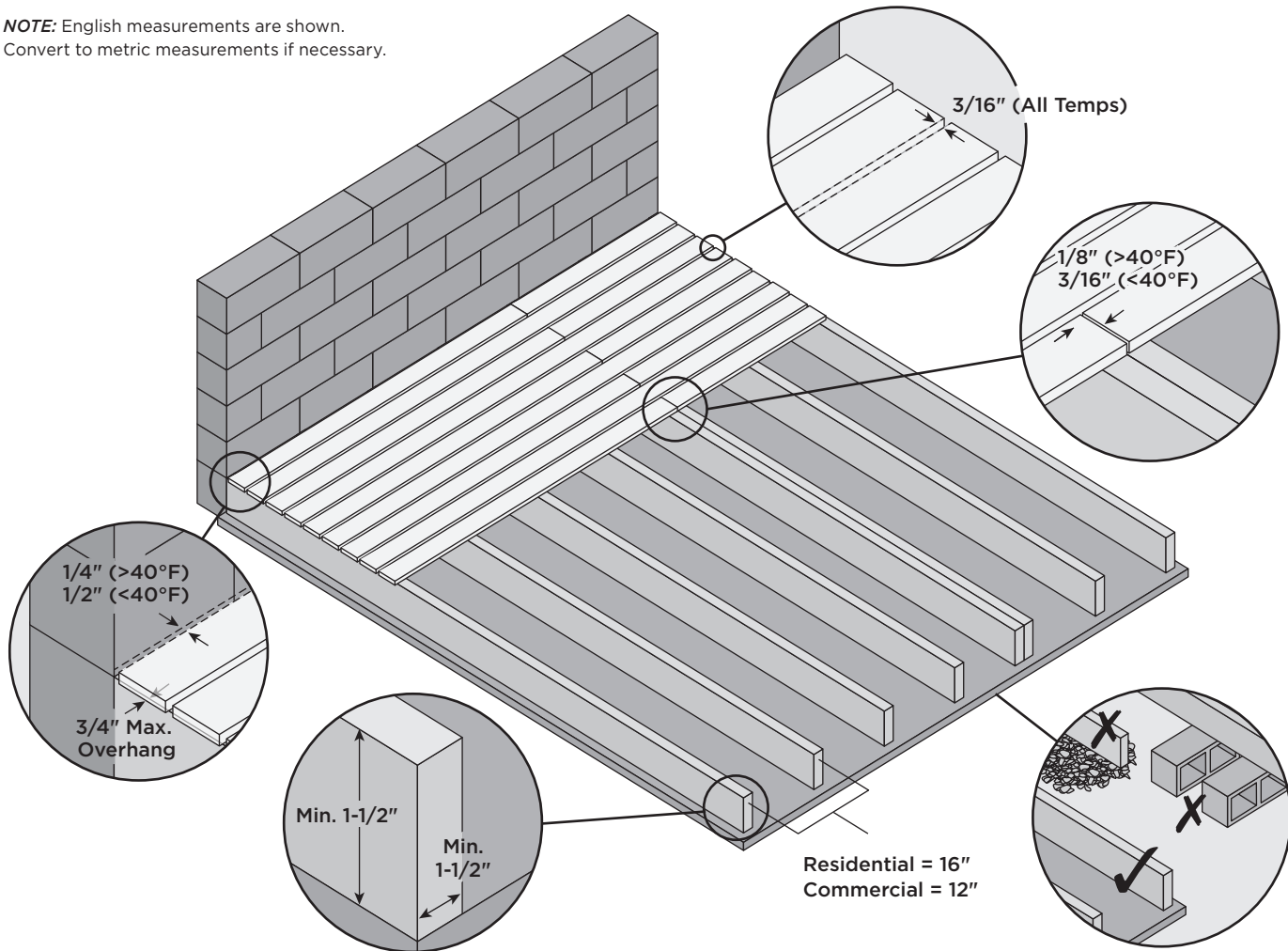

- » It is recommended that building-code approved structural material be used as the supports.
- » This system should not be allowed to float. It must be attached in a manner that secures the framing/system.
- » The sleeper system must be level and have no uneven undulations. Any uneven areas of the substructure will transfer to the Trex decking, resulting in uneven decking.
- » Trex, when used with a sleeper system, must be supported below its entire length. If using in a roofing application, the supports must run the direction of the pitch of the roof to facilitate proper drainage. Sleeper should be placed perpendicular to the deck board orientation.
- » For commercial applications, consult a local building code official for specific requirements.
- » If installing decking at an angle, decrease spans 4" (100 mm) for each of the above. (12" (305 mm) for residential and 8" (204 mm) for commercial.)
- » For sleeper systems where small debris (pine needles, leaves, sand, dirt) can accumulate either between or under deck boards, a minimum of 1-1/2" (38mm) height is allowable. Trex recommends the use of Trex Universal Hidden Fasteners or 2" Starborn Cap-Tor® xd - Epoxy Coated screws. **NOTE:** Trex recommended composite decking screws are too long when using 1-1/2" (38 mm) height as this will penetrate through the sleeper. For areas with the potential for debris buildup, a minimum 3-1/2" (89 mm) or greater height is recommended to allow the debris to be removed along with the use of either Trex Universal Hidden fasteners or any Trex recommended screws.
- » **Always** consult your local building code authority for proper details on roof and railing installation to the roof structure if required.
- » Any deviation from these recommendations could result in voiding of the Trex warranty.

NOTE: Construction methods are always improving. Please refer to www.trex.com for the most up-to-date installation requirements.

Metal Framing Requirements and Gapping

NOTE: Metric measurements are shown.
Convert to US measurements if necessary.

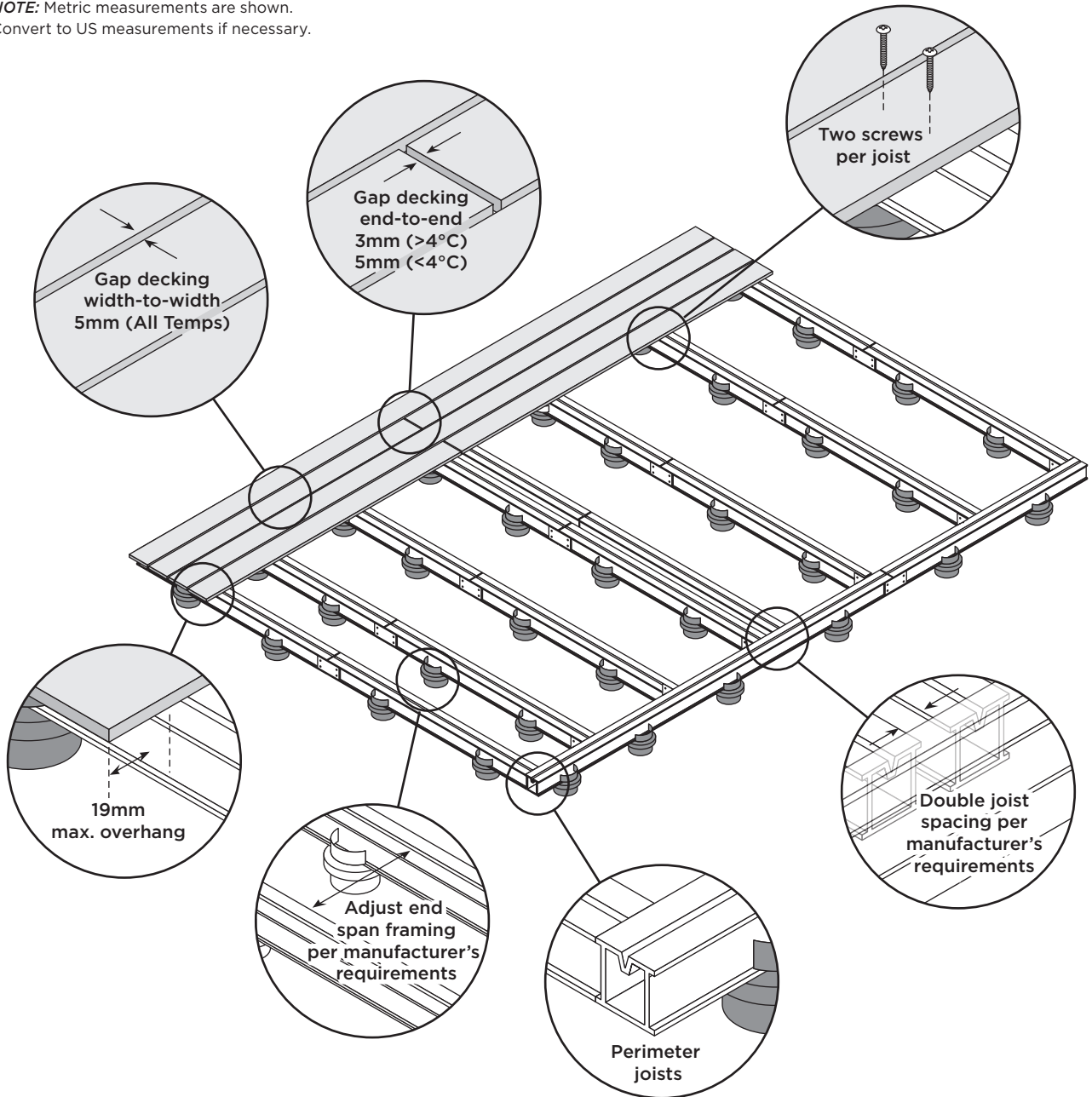

NOTES:

- » When using an aluminum framing system or other type of metal for sleeper systems, follow manufacturer's instructions for proper installation.
- » Depending on type of structure being used, different types of fasteners must be used for attachment.
- » When using screws to attach decking to framing, use two screws per every joist.

Code Compliance

Joist Spanning for Decking

Trex decking meets all applicable national model building codes. The joists must be spaced on center according to the chart below. Be sure that joists are level and plumb. Trex decking must span at least three joists. For heavy items such as hot tubs, planters, etc., consult a local building engineer or inspector for span recommendations. If you want to minimize the appearance of joists through the spaces between boards, use Trex Protect® Joist and Beam Tape or paint the top of your joists black.

Code Listings

Trex complies with major model building codes and has been evaluated by the International Code Council evaluation service.

For a Safety Data Sheets (SDS), please visit www.trex.com.

Adjust Joist Spanning to Accommodate Angled Decking Patterns

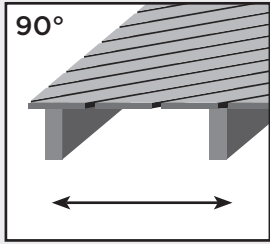

90°

Perpendicular to joists.
See chart below.

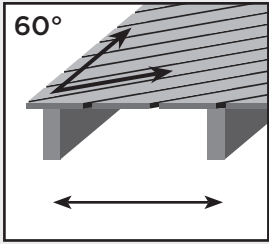

60°

At a 60° angle, maximum joist spanning is 2" (51 mm) less than listed in the chart below.

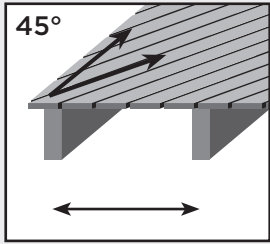

45°

At a 45° angle, maximum joist spanning is 4" (102 mm) less than listed in the chart below.

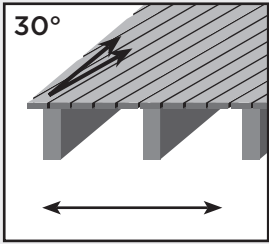

30°

At a 30° angle, maximum joist spanning is 1/2 of the distance listed in the chart below.

Trex Decking Span Chart (on center)			
	Residential Decks, Light Duty Docks, Residential/Day Care Playground	Commercial Decks, Boardwalks and Marinas	
Decking Loading	100 psf = 4.8 kN/m ²	100 psf = 4.8 kN/m ²	200 psf = 9.5 kN/m ²
1" (25 mm) Boards (including Porch), and .875" (22 mm) Select Boards	16" (406 mm)	16" (406 mm)	12" (305 mm)
2" x 6" (51 mm x 152 mm) Boards	24" (610 mm)	24" (610 mm)	16" (406 mm)

Trex Railing Span Chart	
Maximum Railing Span for all Applications	
Transcend, Select railing, and Trex Signature railing	96" on center (2438 mm) for Transcend, 72" on center (1829 mm) for Select, 96" (2438 mm) clear span for Trex Signature <i>Note: Glass installation spanning varies, see specific instructions for details</i>

Gapping and Overhang

You must gap Trex decking both end-to-end and width-to-width. Gapping is necessary for drainage and the slight thermal expansion and contraction of Trex decking boards. Gapping also allows for shrinkage of the wood joist system.

- » **ALWAYS** follow Trex-recommended gapping guidelines.
- » Maximum allowable perpendicular overhang for all Trex decking is 3/4" (19 mm).
- » All decks require air circulation to keep them dry and looking good. To improve air flow, leave openings under the decking or increase gapping to 3/8" (10 mm).

Width-to-Width Gap
3/16" (5 mm)

End-to-End/End-to-Width and Abutting Gap		
	End-to-End/ End-to-Width	Abutting Gap
Above 40°F* (4.5°C)*	1/8" (3 mm)	1/4" (6 mm)
Below 40°F* (4.5°C)*	3/16" (5 mm)	1/2" (13 mm)

*Temperature at installation.

When you use the recommended hidden fasteners, the placement of the hidden fastener establishes the designated gap size.

When installing fascia, gapping rules must apply.

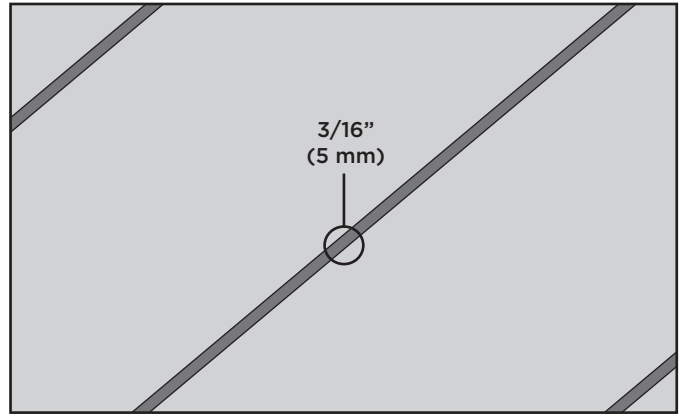

Width-to-Width

The minimum required width-to-width gapping is 3/16" (5 mm). This is allowed for both hot and cold weather installations. For docks and heavily wooded areas, Trex recommends a 3/8" (10 mm) gap. No gapping should ever exceed 1/2" (13 mm).

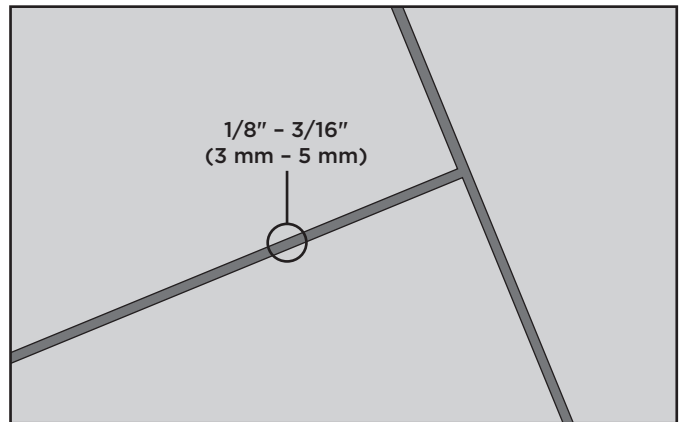

End-to-End/End-to-Width

Gap Trex decking end-to-end, based upon the temperature at installation. See chart at left. For fastening tips, see page 26.

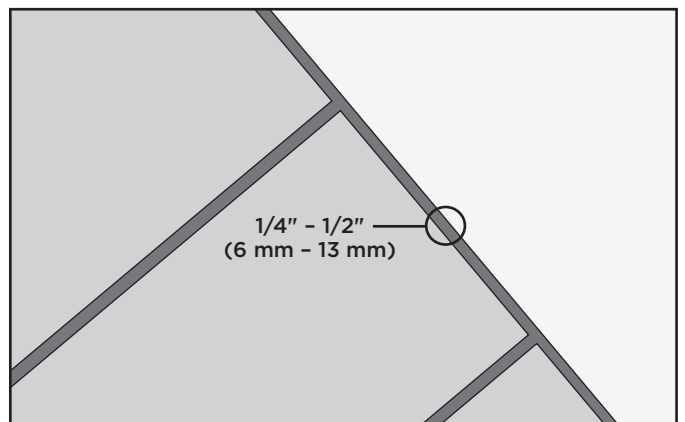

Abutting Solid Objects

When decking is abutting a wall, you must also gap it 1/4"-1/2" (6-13 mm) depending on the temperature at installation. See chart at left.

Important Notes Before Installing Trex® Decking

It is recommended to clean cut boards on both ends a minimum 3/16" (5mm).

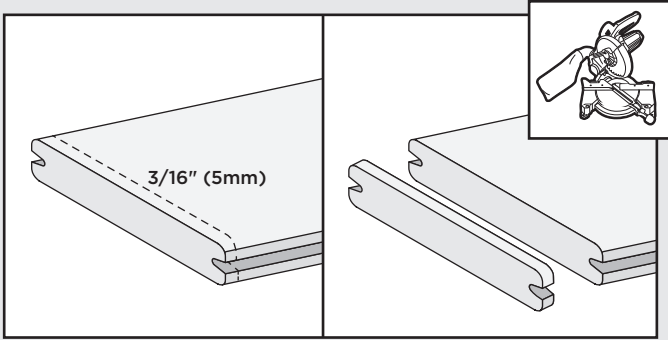

To ensure an appealing mix of color tones, mix and match all boards prior to installation.

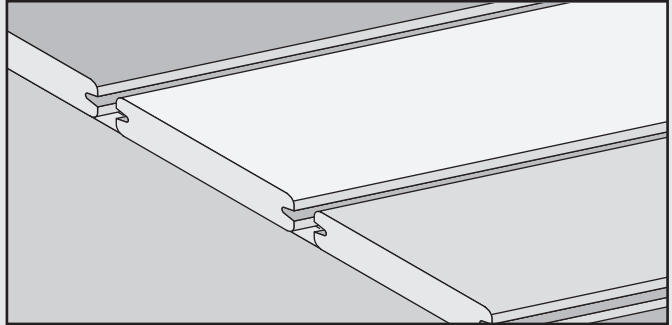

If installing in localities prone to large temperature shifts within a 24-hour period, and installing Trex Universal Hidden Fasteners, pre-drill and toenail a screw (use same screw used in hidden fasteners) at an angle in groove at both ends (at least 1" (25mm) from board end) and center of each board.

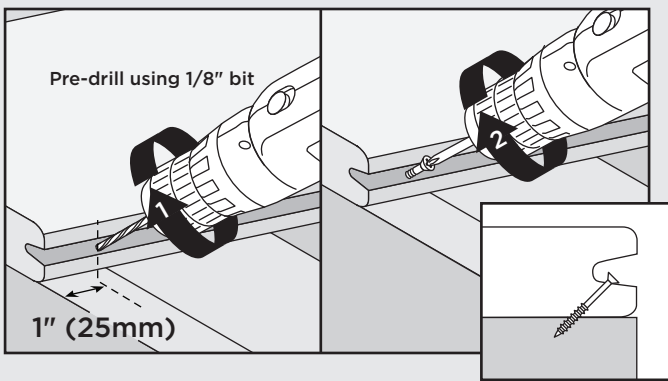

Abutted Board Attachment Requirements

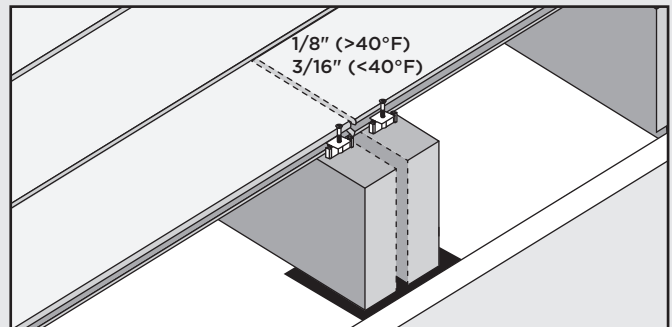

NOTE: Optional - Gap joist framing 1/8" - 3/16" to allow for water drainage.

Metal Framing

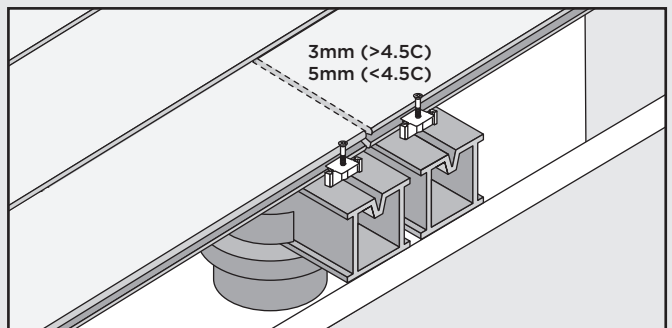

NOTE: Hidden Fasteners **MUST** be used at every joist.

NOTE: Use a drill (with adjustable clutch and torque) and adjust these settings if necessary to ensure screw is seated correctly in fastener. **DO NOT** countersink the screw head into the fastener. Screw head should be flush with the top of the fastener.

Routing Square Edge Boards for Trex Hideaway® Hidden Fasteners

NOTE: All Trex square edge profiles, either 1x6 or 2x6, can be routed.

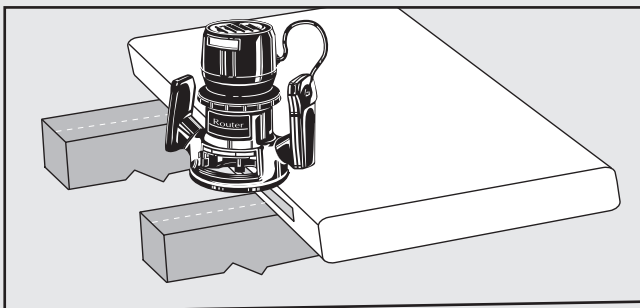

Using a Trex routerbit with standard router:

1. Rout from bottom side of board.
2. Rout the entire length of the board, or at every intersection where board is over support joists.

Installing Trex Transcend®, Enhance®, Select® Deckboards

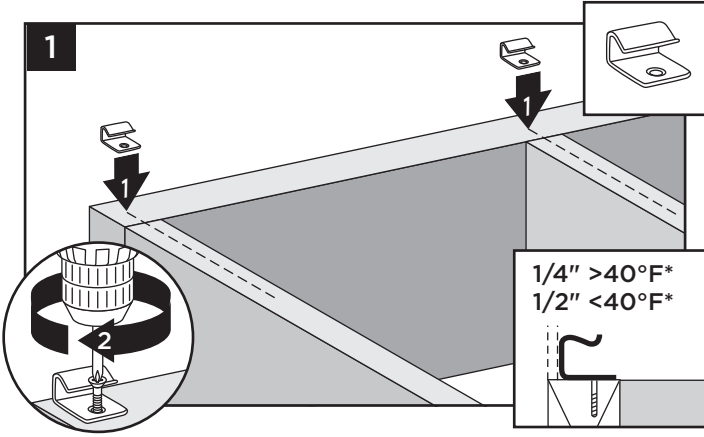

*6mm >4°C 13mm <4°C

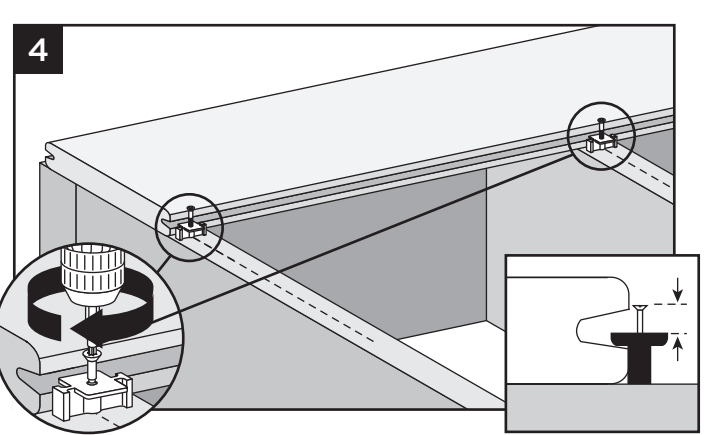
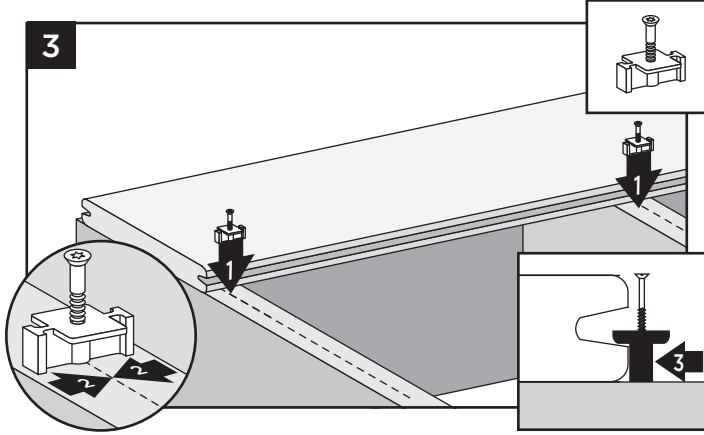
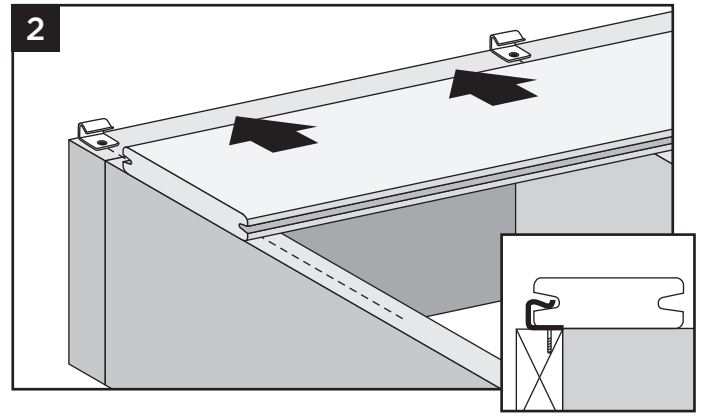

NOTE: Use scrap piece of decking to help hold fastener in place while attaching.

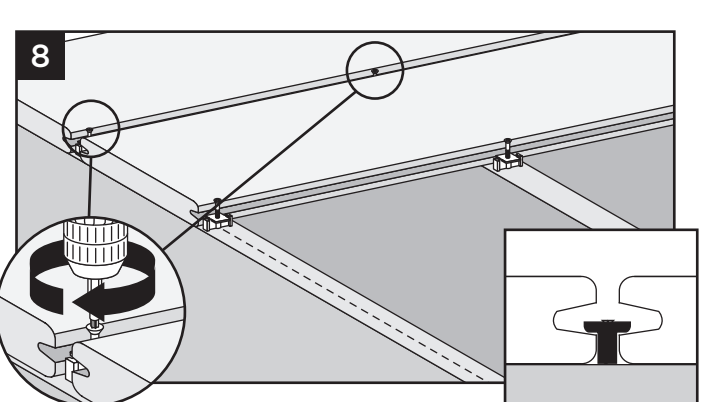
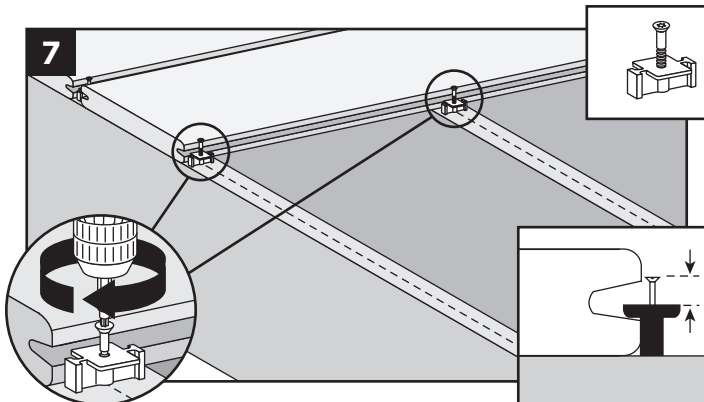
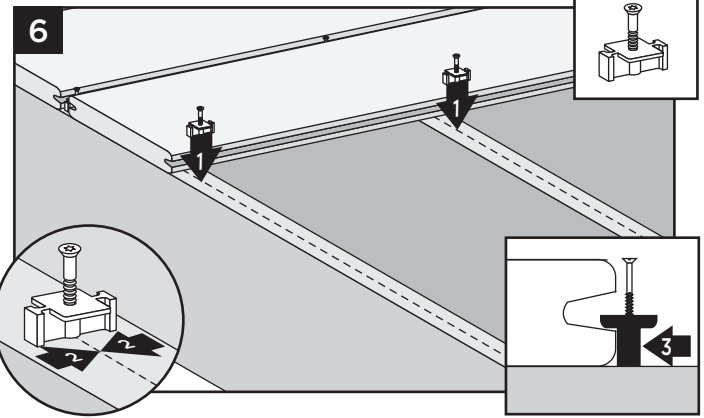
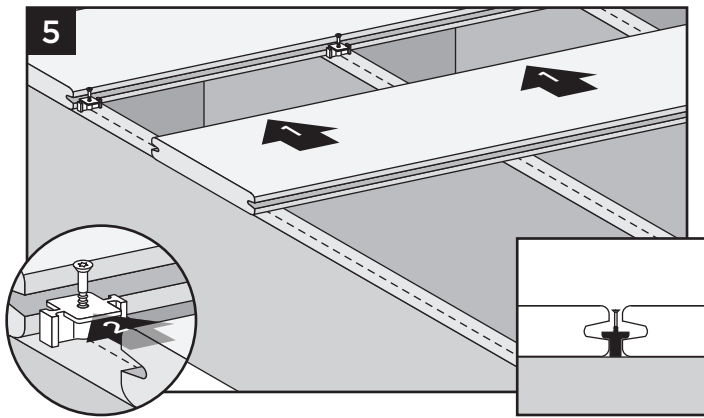

Installing Trex Transcend®, Enhance®, Select® Deckboards/continued

Installing Last Deck Board (Square-Edge Board Recommended)

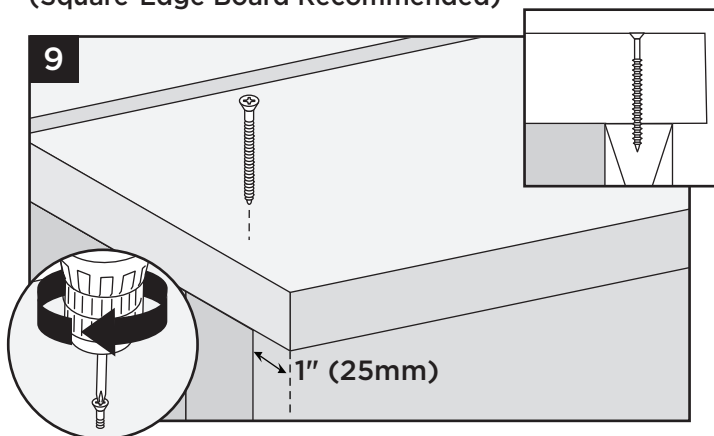

Route one side of square-edge board to use with hidden fasteners.

TIP: Use a recommended hidden fastener screw and plug for last board installation.

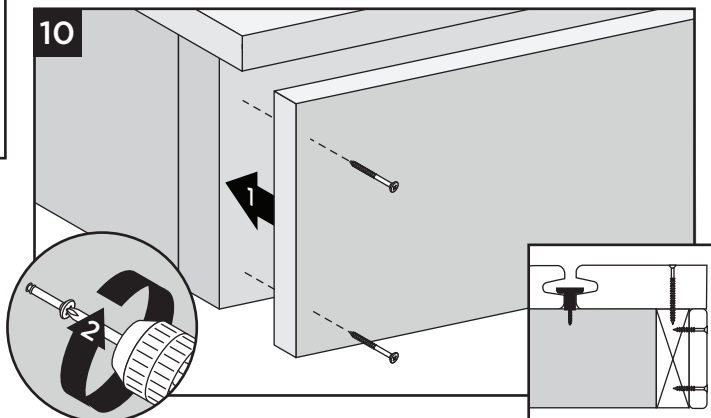

Fascia screws supplied by installer (1 x 8 fascia shown)

NOTE: Refer to page 25 for detailed fascia attachment instructions.

Replacing Trex Boards (Transcend®, Enhance®, Select)

Installed with Trex Hideaway® Universal Fasteners

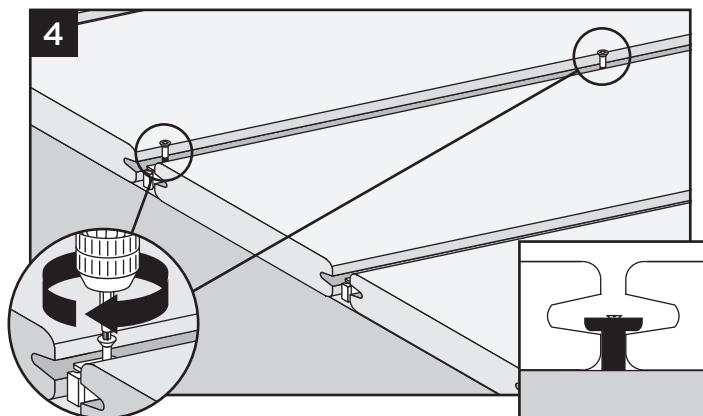
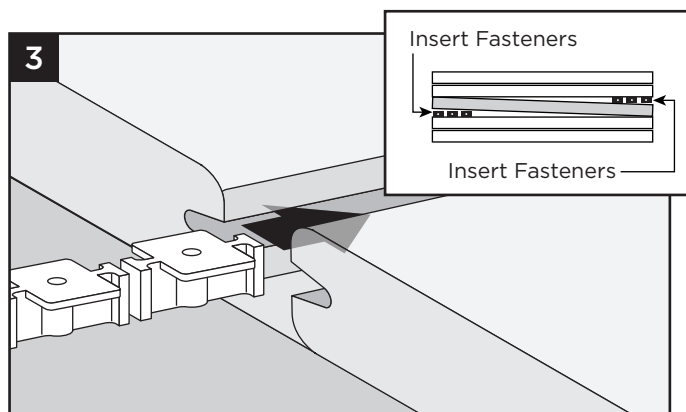
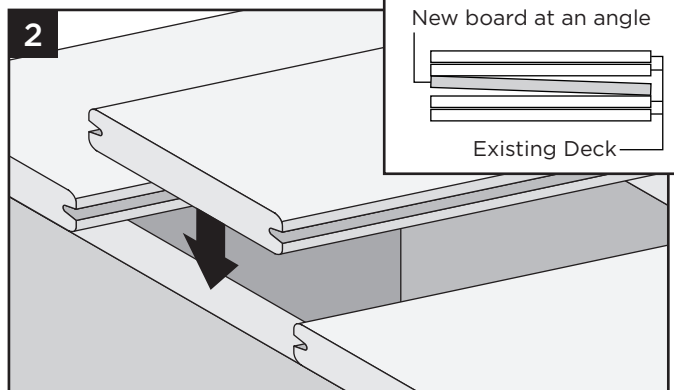
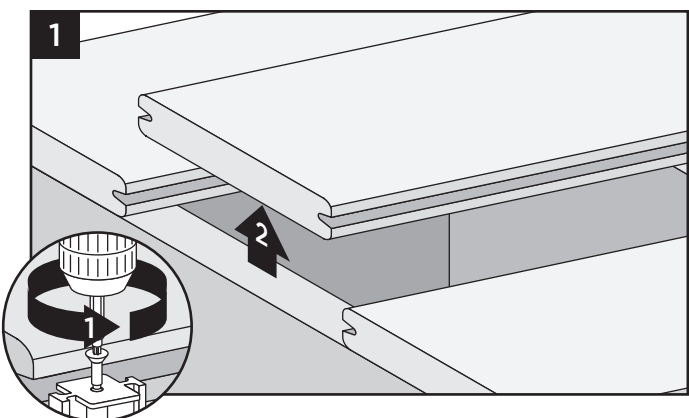

Spanning Requirements for Trex® Stairs

Note: English measurements are shown. Convert to metric measurements if necessary.

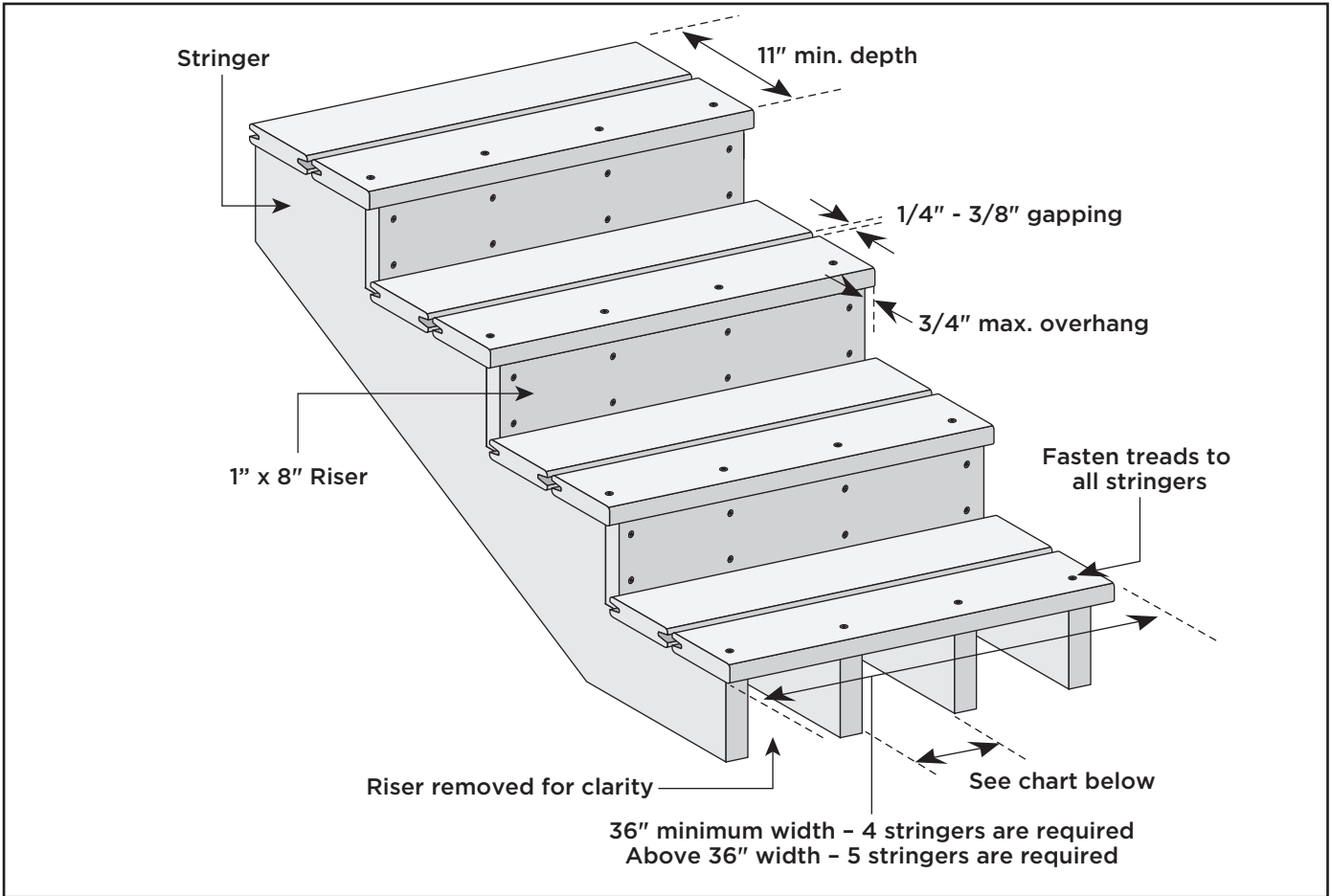

Stairs

Stairway Detail

- » Stair treads built with Trex meet requirements of the major national building codes. Consult your local municipality for specific requirements.
- » Fasten stair treads continuously across at least four stringers.
- » See chart (at right) for center-to-center spacing of profiles.
- » Dress the sides of the stringers and risers with trim or Trex fascia for a finished look.
- » When installing risers, use two screws per every stringer.
- » Fascia fasteners can only be used if fascia boards are being used for risers. If deck boards are used, recommended composite deck screws must be used (glue is not required for this application).
- » Most model building codes require the stair treads to be constructed under the following requirements:
 - › Stairways must be at least 36" wide*
 - › Stair treads must be at least 11" deep
- » Gapping between Trex boards on stair treads must be 1/4"-3/8".
- » The overhang of the stair tread is not to exceed 3/4".

NOTES:

- » Trex rails meet all major building codes for use as a guardrail system. Local municipalities may require a graspable handrail on stairways. Check with your local building code official for local requirements. See Trex ADA Handrail System in the Trex product catalog.

Maximum Spacing on Center of Stair Stringer	
Transcend 1" x 6"	12"
Select & Enhance (scalloped bottom)	9"
Transcend & Select 2" x 6"	12"

*For railings that are installed directly over stair treads, the stair treads may need to be larger than 36" wide. Refer to local building code regulations for details prior to installing stairs and railings.

Installing Trex® Stair Treads

Installed with Hidden Fasteners

NOTE: If using hidden fasteners, use square-edge, composite decking boards and manually route these on required sides to allow for use with hidden fasteners. In addition, if not using hidden fasteners, square-edge boards can all be used and face fastened using Trex recommended fasteners.

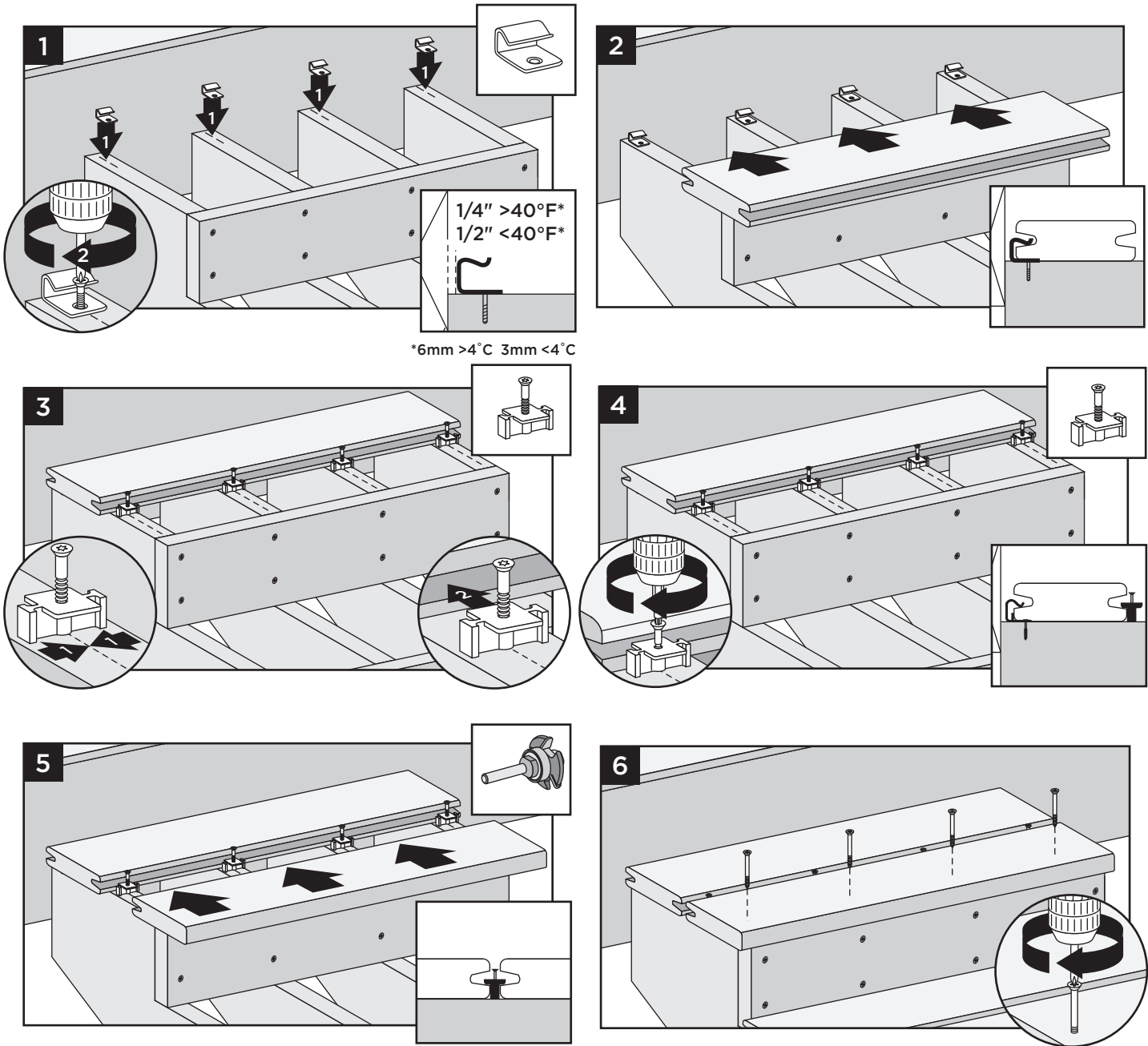

Rout one side of board (last stair tread).

LOCATION AND INSTALLATION OF SURFACE MOUNT POST - DECKING

IMPORTANT NOTES:

- » **EACH POST MUST BE ATTACHED AS SHOWN TO ENSURE A CODE COMPLIANT AND SAFE INSTALLATION.**
- » ALWAYS REFER TO YOUR LOCAL BUILDING CODE OFFICIAL PRIOR TO INSTALLING ANY RAILING SYSTEM TO ENSURE ALL CODE AND SAFETY REQUIREMENTS ARE MET. TREX® CANNOT BE HELD RESPONSIBLE FOR IMPROPER OR NON-RECOMMENDED INSTALLATIONS.
- » WHEN INSTALLING TREX POST MOUNTS ON ACQ OR CCA SURFACES, USE AN APPROPRIATE ISOLATION BARRIER BETWEEN POST AND SURFACE (CONTACT LOCAL BUILDING CODE OFFICIAL IF NEEDED).
- » ENSURE THAT CORRECT SKU HARDWARE IS ORDERED FOR THE TYPE OF RAILING BEING INSTALLED.
- » CANNOT BE USED WITH TREX TRANSCEND COCKTAIL RAILING.

TOOLS AND MATERIALS NEEDED

- » Drill and/or screw gun
- » 1/2" (1.27 cm) drill bit for wood
- » Blocking - 2" x 8" (5.1 cm x 20.3 cm) pressure-treated Southern Yellow Pine or equivalent
- » Qty: 36 (per post) - 3" pressure-treated compatible wood screws

PARTS

- » (1) Post mount
- » (2) Guide blocks
- » (18) #8-15 x 1-1/4" (3.2 cm) screws
- » (2) 10 x 1" (2.5 cm) Self-tapping screws

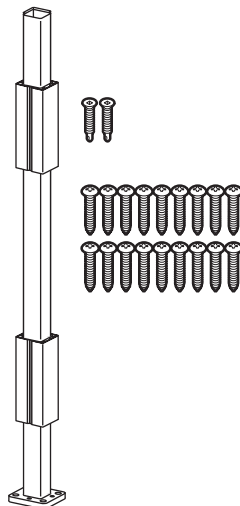

SKU ALPOSTHWDECK

(this SKU SOLD SEPARATELY and must be used for code-approved applications)

- » (4) 3/8" x 6" (1 cm x 15.2 cm) Hex cap bolts
- » (1) Back plate
- » (8) Flat washers
- » (4) Hex nuts

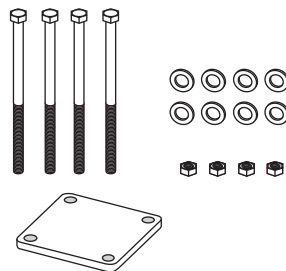

Installing Post Mounts on Pressure-treated Wood Framing

Corner Post Installation

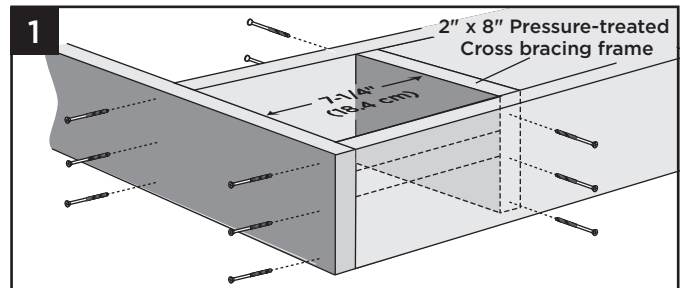

1. Install 2" x 8" (5.1 cm x 20.3 cm) cross bracing frame in between joists at 7-1/4" (18.4 cm). Attach a total of twelve 3" (7.6 cm) pressure-treated compatible screws (not provided).

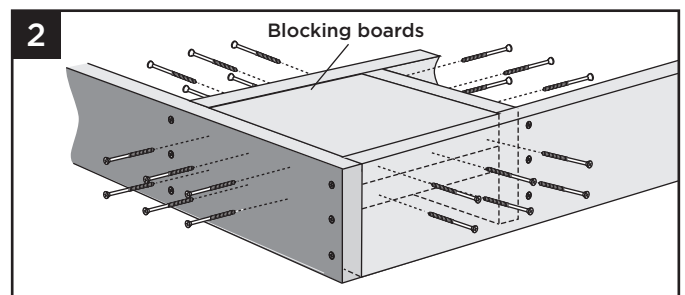

2. Install two 2" x 8" (5.1 cm x 20.3 cm) boards as blocking under post location. Securely attach blocking using a total of twenty-four 3" (7.6 cm) pressure-treated compatible screws (not provided).

NOTE: TO ENSURE THE BLOCKING IS FULLY SECURE, USE THE AMOUNT OF SCREWS INDICATED ABOVE.
TIP: USE TWO ADDITIONAL SCREWS TO "SANDWICH" BLOCKING BOARDS TOGETHER FOR EASIER ATTACHMENT TO FRAMING.

Line Post Installation

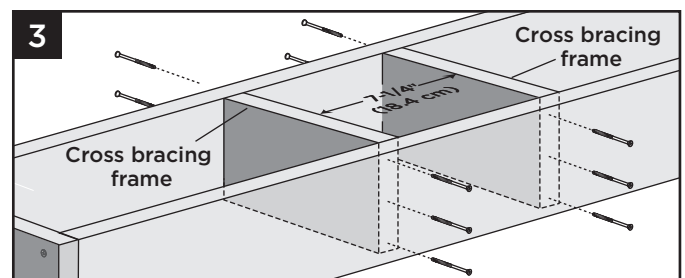

3. Install two 2" x 8" (5.1 cm x 20.3 cm) cross bracing frames in between joists at 7-1/4" (18.4 cm). Attach a total of twelve 3" (7.6 cm) pressure-treated compatible screws (not provided).



LOCATION AND INSTALLATION OF SURFACE MOUNT POST - DECKING/ CONTINUED

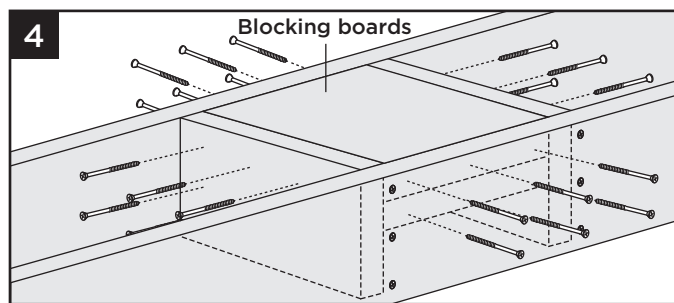

4. Install two 2" x 8" (5.1 cm x 20.3 cm) boards as blocking under post location. Securely attach blocking using a total of twenty-four 3" (7.6 cm) pressure-treated compatible screws (not provided).

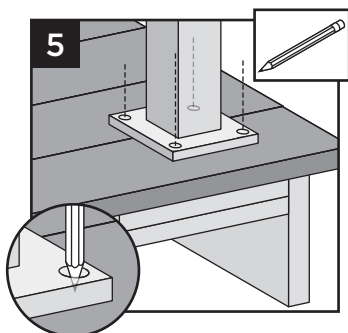

5. Using post a template, mark locations of holes.
6. Drill through decking and blocking boards using 5/8" diameter bit (long drill bit will be required).

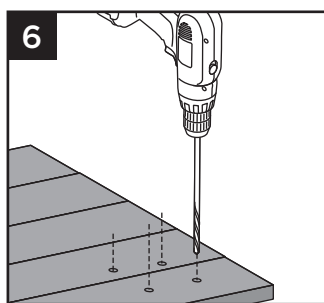

7. Insert the (2) stainless steel barrier strips under the mounting bolt holes. BARRIER STRIPS ARE REQUIRED ONLY IF ATTACHING POST DIRECTLY TO PRESSURE-TREATED FRAMING.

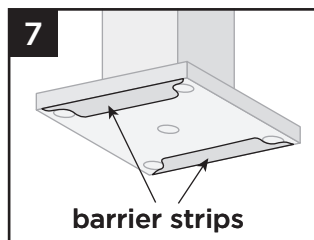

8. Attach posts using four 3/8" x 6" (1 cm x 15.2 cm) hex cap bolts, washers, and nuts, along with aluminum back plate on underside of blocking. If the project requires IRC compliance, this back plate **MUST** be installed under the decking to ensure this will meet code compliance. Reference SKU part number ALPOSTHWDECK for required hardware and aluminum plate. (Consult local code official for more information on IRC Compliance.)

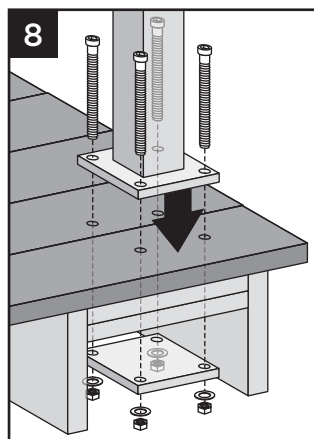

NOTES:

- » Use composite shims or similar material (not provided) if posts are not plumb. Ensure that post is placed on decking surface so that it clears the rim joist and there is enough clearance on the underside blocking for the back plate to be installed.
- » Rim joist removed to show proper attachment of hardware.

Install Guide Blocks

- NOTE:** Pre-drilling is not required but is optional for attachment of guide blocks to post. Use a drill bit slightly smaller in size than that of screw being installed.

9. Place or rest bottom aluminum guide block on bottom of post. Place guide on post so that notch is on a side that does not require railing to be attached.

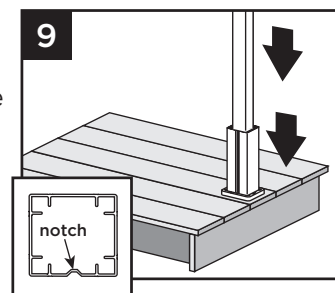

10. Attach bottom guide block using one 10 x 1" self-tapping screw (provided) in notch to lock guide block onto post.

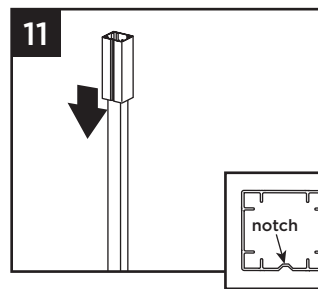
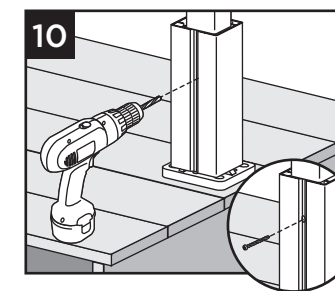

11. Location of top guide block will vary slightly depending on type and height of railing being installed. Determine this measurement and place top guide block in location where top bracket for desired railing would be approximately on center of the top railing bracket location.

12. Attach top guide block using one 10 x 1" self-tapping screw (provided) in notch to lock guide block onto post.

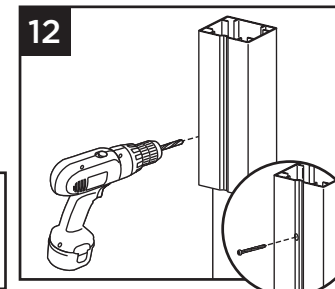

LOCATION AND INSTALLATION OF SURFACE MOUNT POST - DECKING/ CONTINUED

Install Railing System of Choice

NOTES:

- » A quantity of 18 #8-15 x 1-1/4" screws are provided to cover all types of Trex railing bracket installations (Transcend, Trex Signature®, and Select). Depending on the type railing being installed, you may have screws that are not used.
- » If using 6x6 post sleeves, attach designated railing brackets using #8-15 x 1-3/4" (4.4 cm) 316 stainless steel self-tapping screws (not provided).

- » Pre-drilling IS REQUIRED when attaching brackets to designated posts. Use a 9/64" (3.6 mm) drill bit to pre-drill at specified locations according to instructions provided with railing kits.

Note: If installing Trex Deck Lighting on the posts, drill hole through support blocks to allow wiring for lights to be below the surface of the decking.

LOCATION AND INSTALLATION OF IRC-APPROVED POST MOUNTS - CONCRETE

NOTES:

- » **INSTALLATION SHOWN HERE IS FOR IRC APPROVED APPLICATIONS ONLY.**
- » **MAKE SURE CONCRETE IS LEVEL BEFORE INSTALLING POSTS.**
- » **ALWAYS REFER TO YOUR LOCAL BUILDING CODE OFFICIAL PRIOR TO INSTALLING ANY RAILING SYSTEM TO ENSURE ALL CODE AND SAFETY REQUIREMENTS ARE MET. TREX® CANNOT BE HELD RESPONSIBLE FOR IMPROPER OR NON-RECOMMENDED INSTALLATIONS.**
- » **CANNOT BE USED WITH TREX TRANSCEND COCKTAIL RAILING.**

SKU ALPOSTHWCONC

(this SKU SOLD SEPARATELY)

- » (4) 3/8" x 3-3/4" (10 mm x 95 mm) Expansion anchor
- » (4) Flat washers
- » (4) Hex nuts

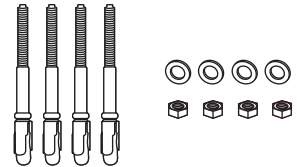

Pre-drill Holes

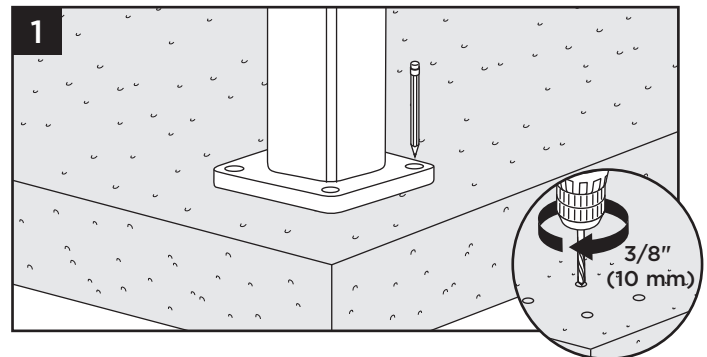

1. Using post as a template, mark locations of the four holes and drill into concrete at least 2-5/8" (66.7 mm) using a 3/8" (10 mm) masonry bit.

NOTE: You can either set drill bit to correct depth on drill or mark drill bit with tape at required dimension to ensure all holes are drilled at the correct depth.

TOOLS NEEDED

- » Hammer
- » Drill and/or screw gun
- » 3/8" (10 mm) drill bit for concrete

PARTS

- » (1) Post mount
- » (2) Guide blocks
- » (18) #8-15 x 1-1/4" (32 mm) screws
- » (2) 10 x 1" (25 mm) Self-tapping screws

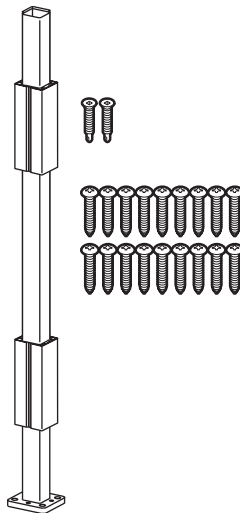

LOCATION AND INSTALLATION OF IRC-APPROVED POST MOUNTS - CONCRETE/CONTINUED

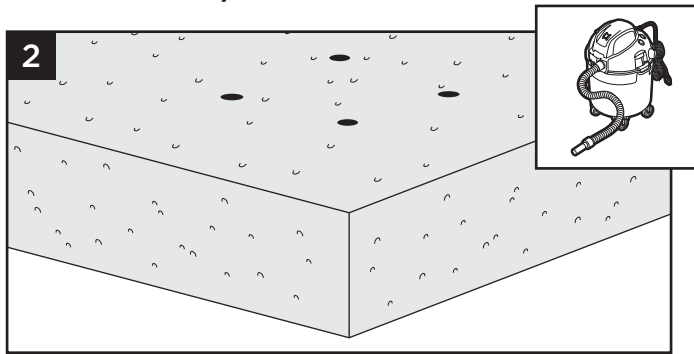

2. Clean out holes to remove all concrete dust.

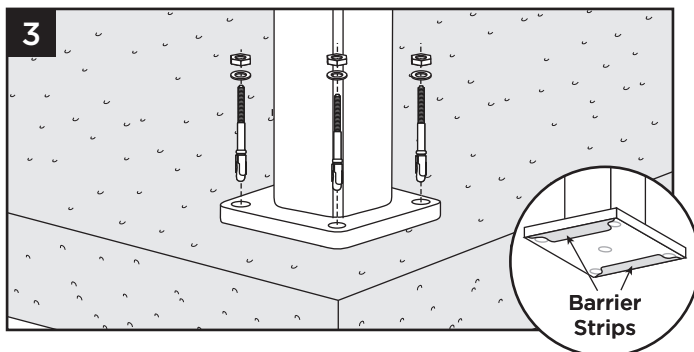

3. Insert the (2) stainless steel barrier strips under the mounting bolt holes. Use appropriate shims if posts are not plumb. Secure post mount with the four expansion anchors, washers and nuts.

NOTE: When using hammer to tap anchors in place, keep the threaded nut at the top of the anchor in order to not damage the threads.

NOTE: Recommended torque for anchors is 20 ft-lbs.

Install Guide Blocks

NOTE: Pre-drilling is not required but is optional for attachment of guide blocks to post. Use a drill bit slightly smaller in size than that of screw being installed.

4. Place or rest bottom aluminum guide block on bottom of post. Place guide on post so that notch is on a side that does not require railing to be attached.

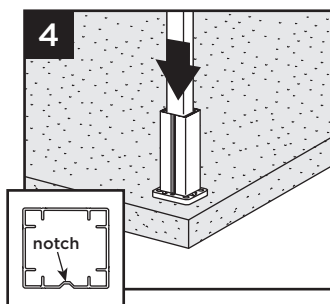

5. Attach bottom guide block using one 10 x 1" (25 mm) self-tapping screw (provided) in notch to lock guide block onto post.

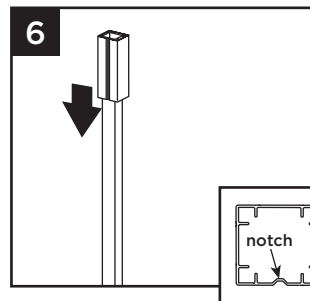
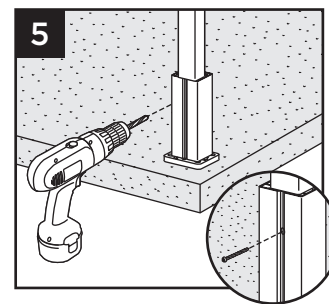

6. Location of top guide block will vary slightly depending on type and height of railing being installed. Determine this measurement and place top guide block in location where top bracket for desired railing would be approximately on center of the top railing bracket location.

7. Attach top guide block using one 10 x 1" (25 mm) self-tapping screw (provided) in notch to lock guide block onto post.

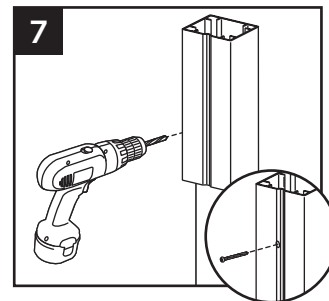

Install Railing System of Choice

IMPORTANT NOTES:

- » A quantity of 18 #8-15 x 1-1/4" screws are provided to cover all types of Trex railing bracket installations (Transcend, Trex Signature®, and Select). Depending on the type railing being installed, you may have screws that are not used.
- » **Pre-drilling IS REQUIRED when attaching brackets to designated posts. Use a 9/64" (3.6 mm) drill bit to pre-drill at specified locations according to instructions provided with railing kits.**
- » If using 6x6 post sleeves, attach designated railing brackets using #8-15 x 1-3/4" (44 mm) 316 stainless steel self-tapping screws (not provided).

NOTE: If installing Trex Lighting on the posts, drill hole through support blocks to allow wiring for lights to be below the surface of the decking.

HOW TO INSTALL JOIST MOUNT POSTS

ALL INSTRUCTIONS BELOW ARE FOR METAL POSTS ONLY; NO PRESSURE-TREATED POSTS ARE TO BE USED FOR THESE INSTRUCTIONS.

Joist Mount Post for Trex Composite Post Sleeve SKU CPJMNTPOST63

- » (1) Joist Mount Post
- » (2) Guide blocks
- » (2) 10 x 1" (2.5 cm) Screws
- » (18) #8-15 x 1-1/4" (3.2 cm) Screws
- » (2) 1/2" x 8" Bolts, Washers, & Nuts

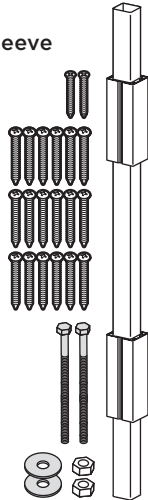

Trex Joist Mount Post for Trex Signature™ Railing SKU XXJMNTPOST63

XX denotes color: (BK-Black, BZ-Bronze, WT-White)

- » (1) Joist Mount Post
- » (2) 1/2" x 8" Bolts, Washers, & Nuts*
- » (1) Post Cap
- » (1) Post Skirt

*NOTE: bolt heads, washers, and nuts are color matched to joist mount post color

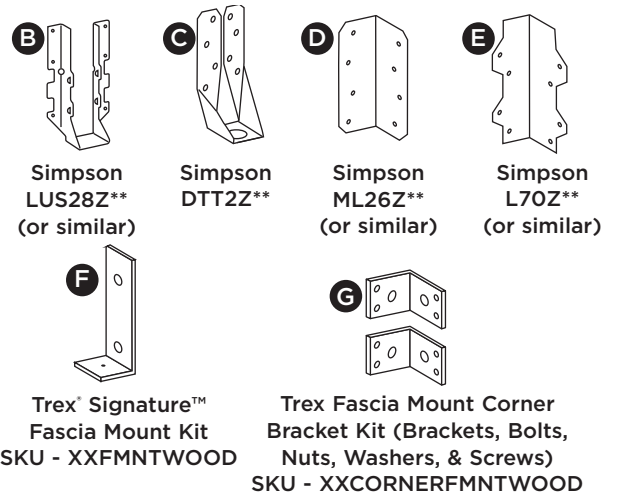
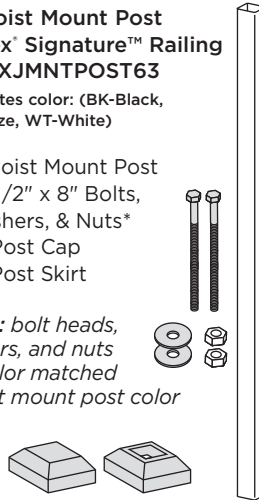

XX denotes color BK-Black, BZ-Bronze, WT-White

GENERAL GUIDELINES

- » **Code-Approved Joist Mount Post Applications:**
 - 30" or less deck height - Code approval not applicable
 - IRC Compliant - Yes
 - IBC Compliant - No
- » Minimum framing is 2"x 8" (51 mm x 203 mm). (Ensure all structural brackets are sized appropriately for framing.)
- » Follow all structural bracket manufacturer's guidelines for fastener selection and corrosion protection requirements.
- » Maximum OC framing is 16" (406 mm).
- » This post is designed to cut-to-length and will accommodate up to 42" (1067 mm) stair railing on 2" x 12" (51 mm x 305 mm) framing.

- » Included template works for most, but not all, applications. Review instructions carefully prior to drilling holes, making sure to center holes on post.
- » **Simpson structural brackets are not included with joist mount posts and must be purchased separately.

HELPFUL TOOLS

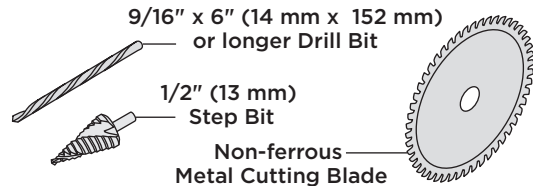

Wood Frame (Inside Mount) Overview

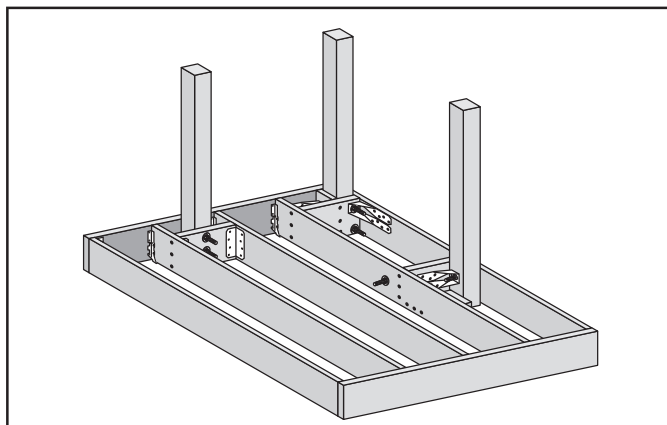

NOTE: To allow fascia to sit flat against framing, route/trim out back side of fascia to allow for fit over bolt locations.

Wood Frame (Fascia Mount) Overview

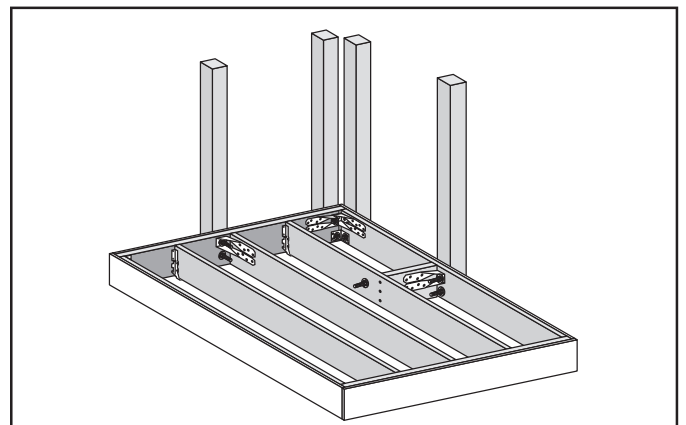

NOTES:

- » Trex fascia should be installed prior to installing any outside joist post mounts.
- » Can only be used with Trex Signature 6' or less railingspans.



NOTE: Construction methods are always improving. Please refer to www.trex.com for the most up-to-date installation requirements.

INSIDE MOUNT (FRONT RIM PLATE - BETWEEN JOISTS WITH BLOCKING)

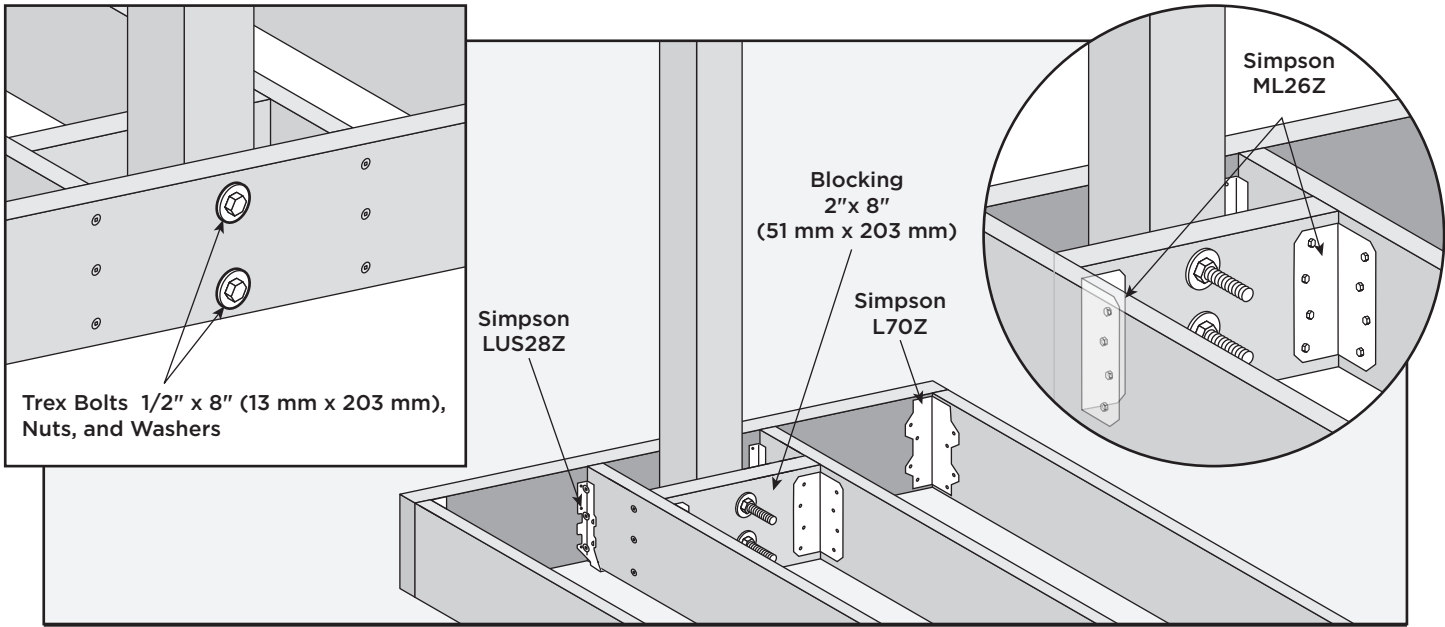

INSIDE MOUNT (FRONT RIM PLATE - NEXT TO JOIST)

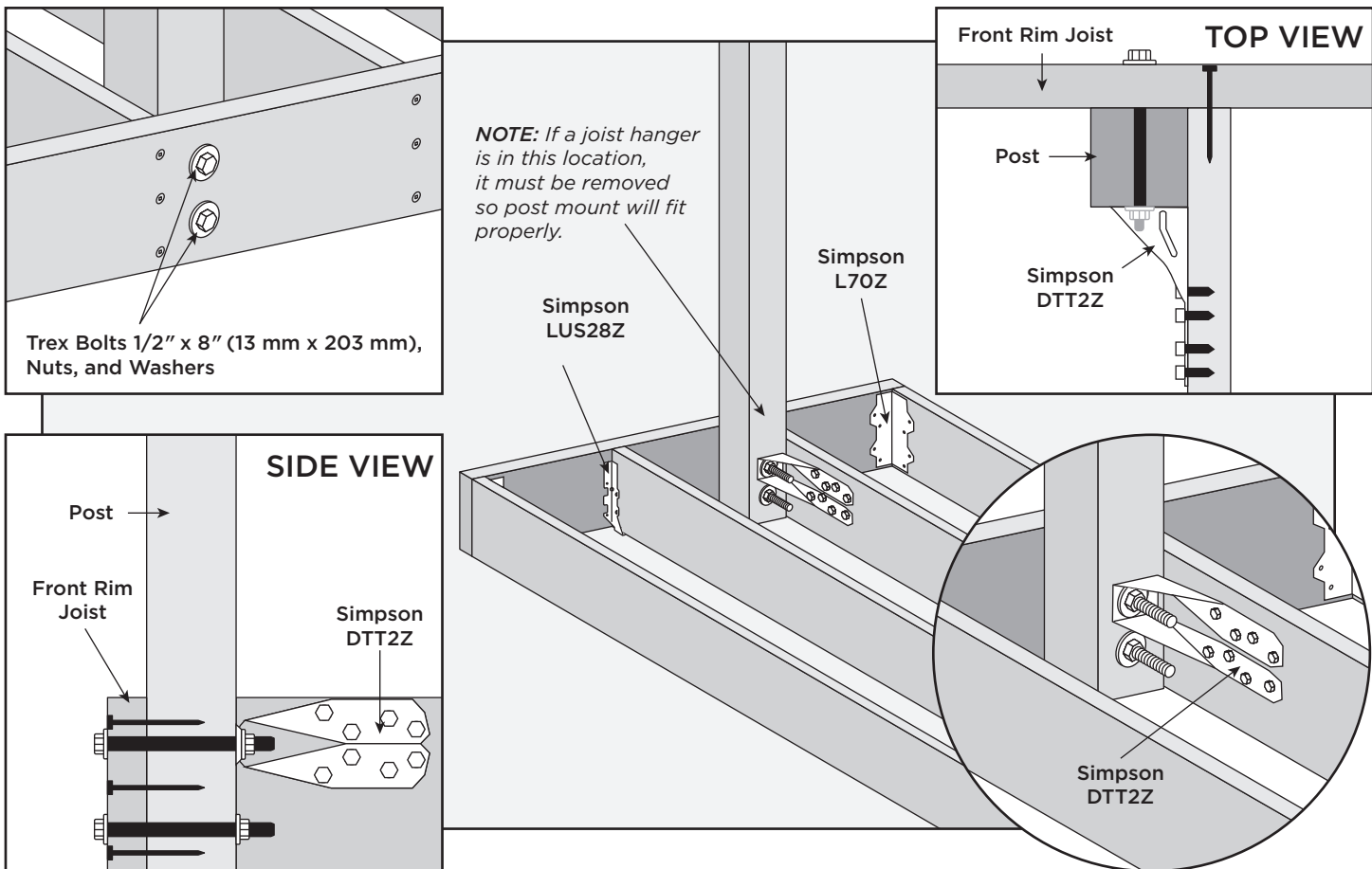

INSIDE MOUNT (SIDE JOIST)

- » TREX SUPPLIES (2) HG 1/2" X 8" (13 MM X 203 MM) BOLTS, NUTS, AND WASHERS.
- » CUSTOMER MUST SUPPLY ADDITIONAL HG 1/2" X 8" (13 MM X 203 MM) BOLTS, NUTS, AND WASHERS.

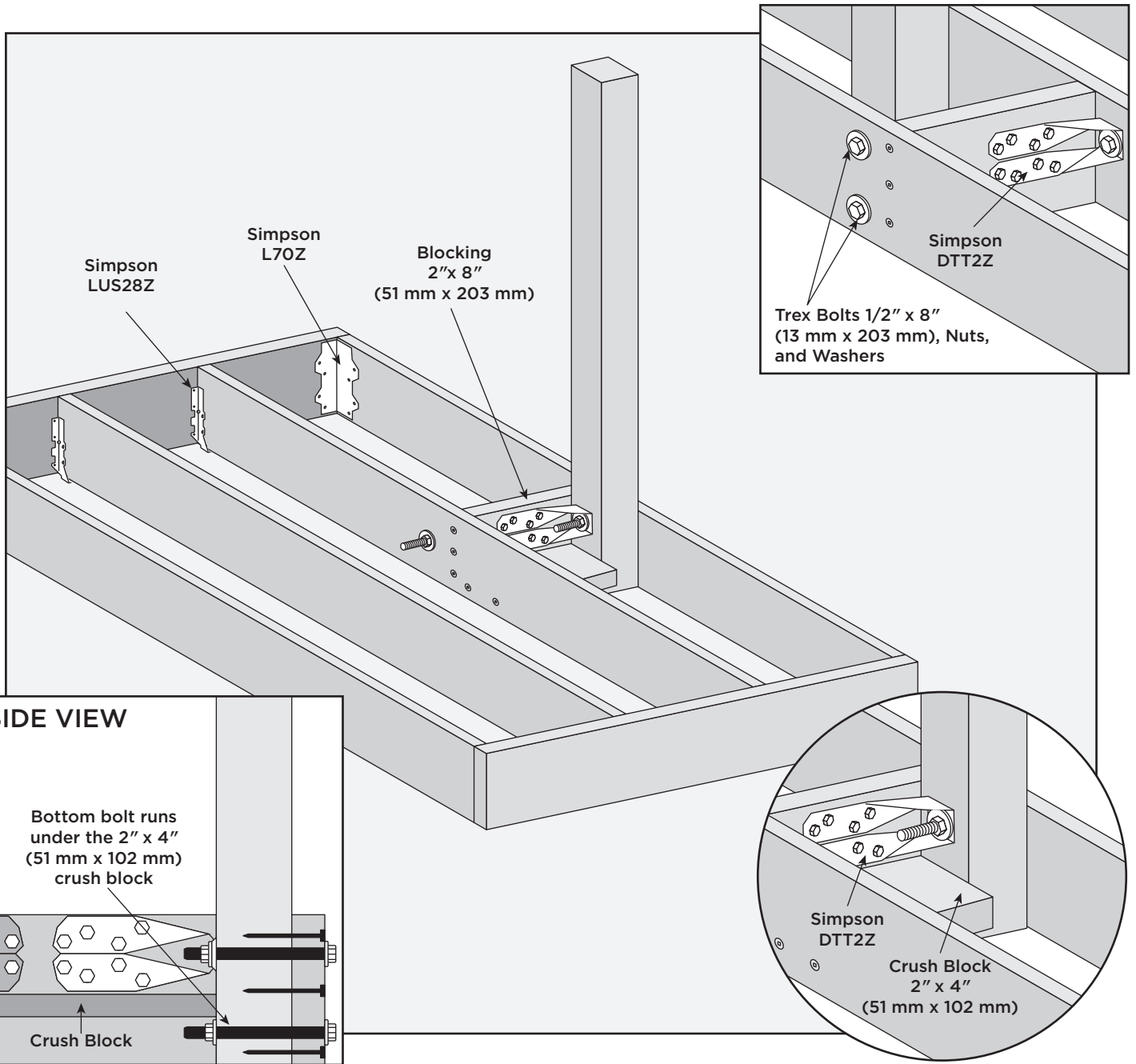

INSIDE MOUNT (CORNER)

- » TREX SUPPLIES (2) HG 1/2" X 8" (13 MM X 203 MM) BOLTS, NUTS, AND WASHERS.
- » CUSTOMER MUST SUPPLY ADDITIONAL HG 1/2" X 8" (13 MM X 203 MM) BOLTS, NUTS, AND WASHERS.

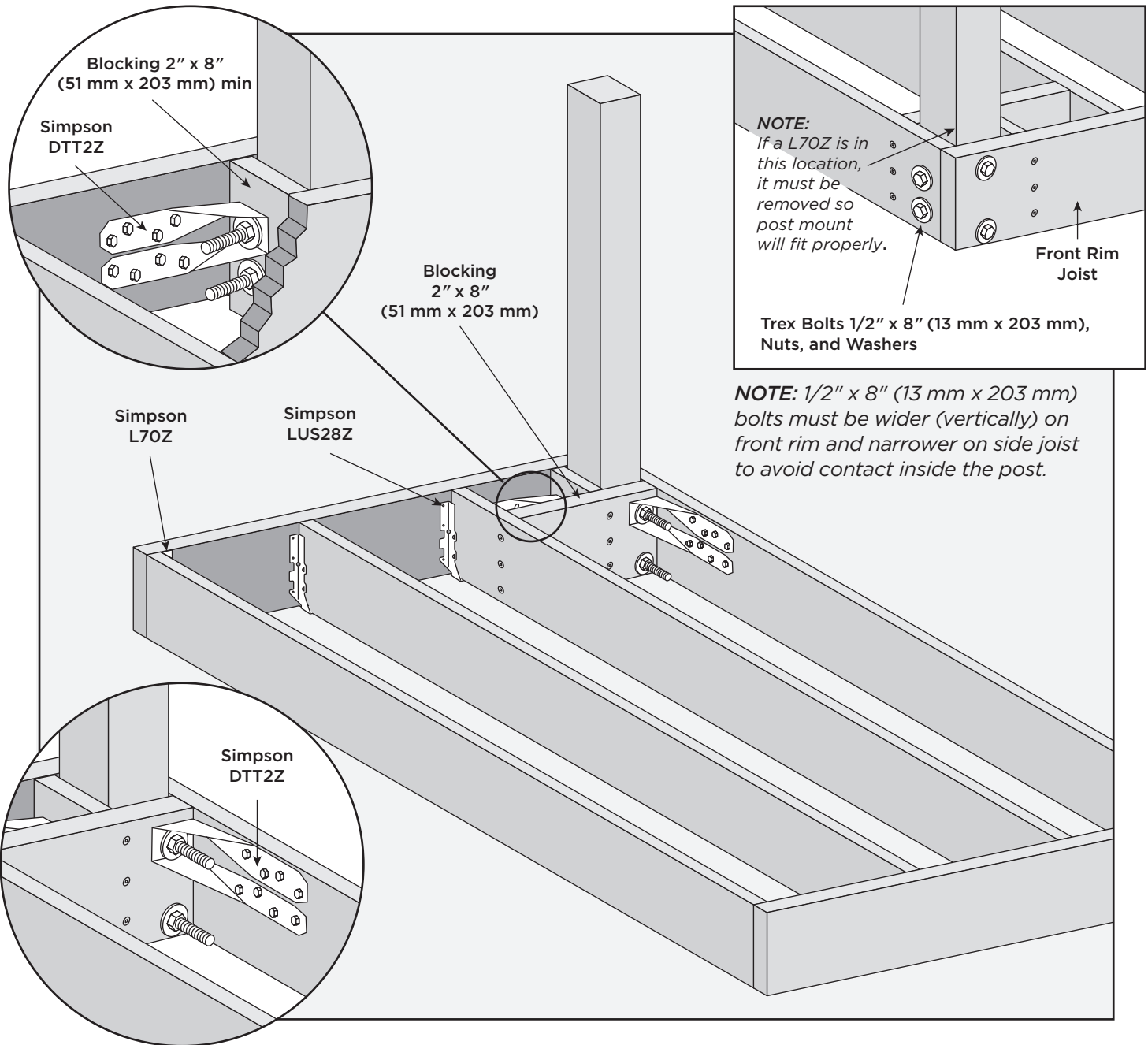

COMPOSITE POST SLEEVE APPLICATIONS

Installation of Guide Blocks and Railing

NOTE: Pre-drilling is not required but is optional for attachment of guide blocks to post. Use a drill bit slightly smaller in size than that of screw being installed.

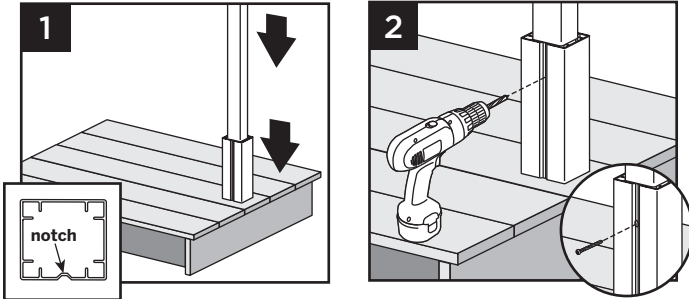

1. Place or rest bottom aluminum guide block on bottom of post. Place guide on post so that notch is on a side that does not require railing to be attached.
2. Attach bottom guide block using one 10 x 1" self-tapping screw (*provided*) in notch to lock guide block onto post.

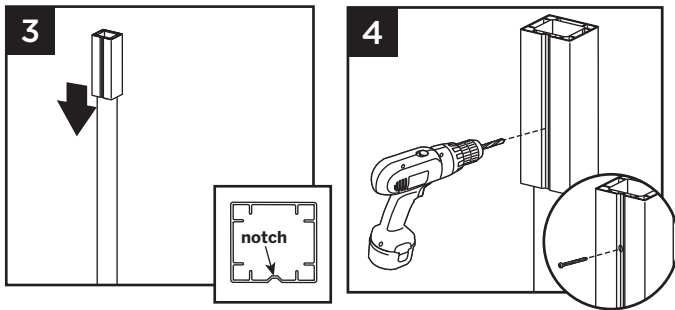

3. Location of top guide block will vary slightly based on type and height of railing being installed. Determine this measurement and place top guide block in location where top bracket for desired railing would be approximately on center of the top railing bracket location.
4. Attach top guide block using one 10 x 1" self-tapping screw (*provided*) in notch to lock guide block onto post.

- » If using the joist mount post with composite post sleeve, a quantity of 18 #8-15 x 1-1/4" screws are provided to cover all types of Trex railing bracket installations (Trex Signature, Transcend and Select). Therefore, depending on the type railing being installed, you may have screws that are not used.
- » If using 6x6 post sleeves, attach designated railing brackets using #8-15 x 1-3/4" (4.4 cm) 316 stainless steel screws (*not provided*).
- » **Pre-drilling IS REQUIRED** when attaching brackets to designated posts. Use a 9/64" (3.6 mm) drill bit to predrill at specified locations according to instructions provided with railing kits.



FASCIA MOUNT (FRONT RIM PLATE - NEXT TO JOIST)

» FOR USE WITH TREX SIGNATURE 6' RAILING SECTIONS ONLY.

» TREX SUPPLIES (2) HG 1/2" X 8" (13 mm x 203 mm) BOLTS, NUTS, AND WASHERS.

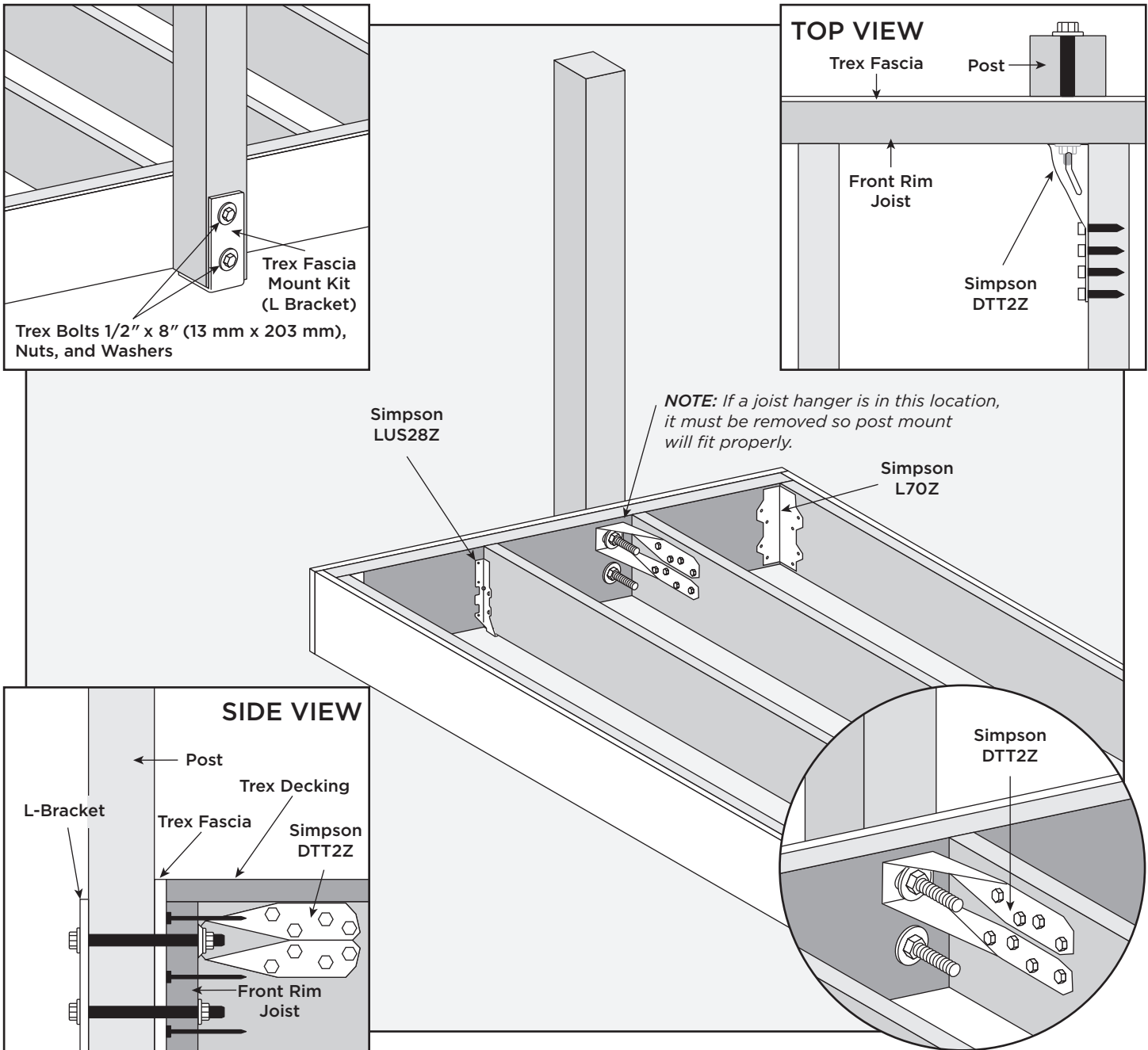

FASCIA MOUNT (SIDE JOIST - WITH BLOCKING)

- » TREX SUPPLIES (2) HG 1/2" X 8" (13 mm x 203 mm) BOLTS, NUTS, AND WASHERS.
- » CUSTOMER MUST SUPPLY ADDITIONAL HG 1/2" X 8" (13 mm x 203 mm) BOLTS, NUTS, AND WASHERS.

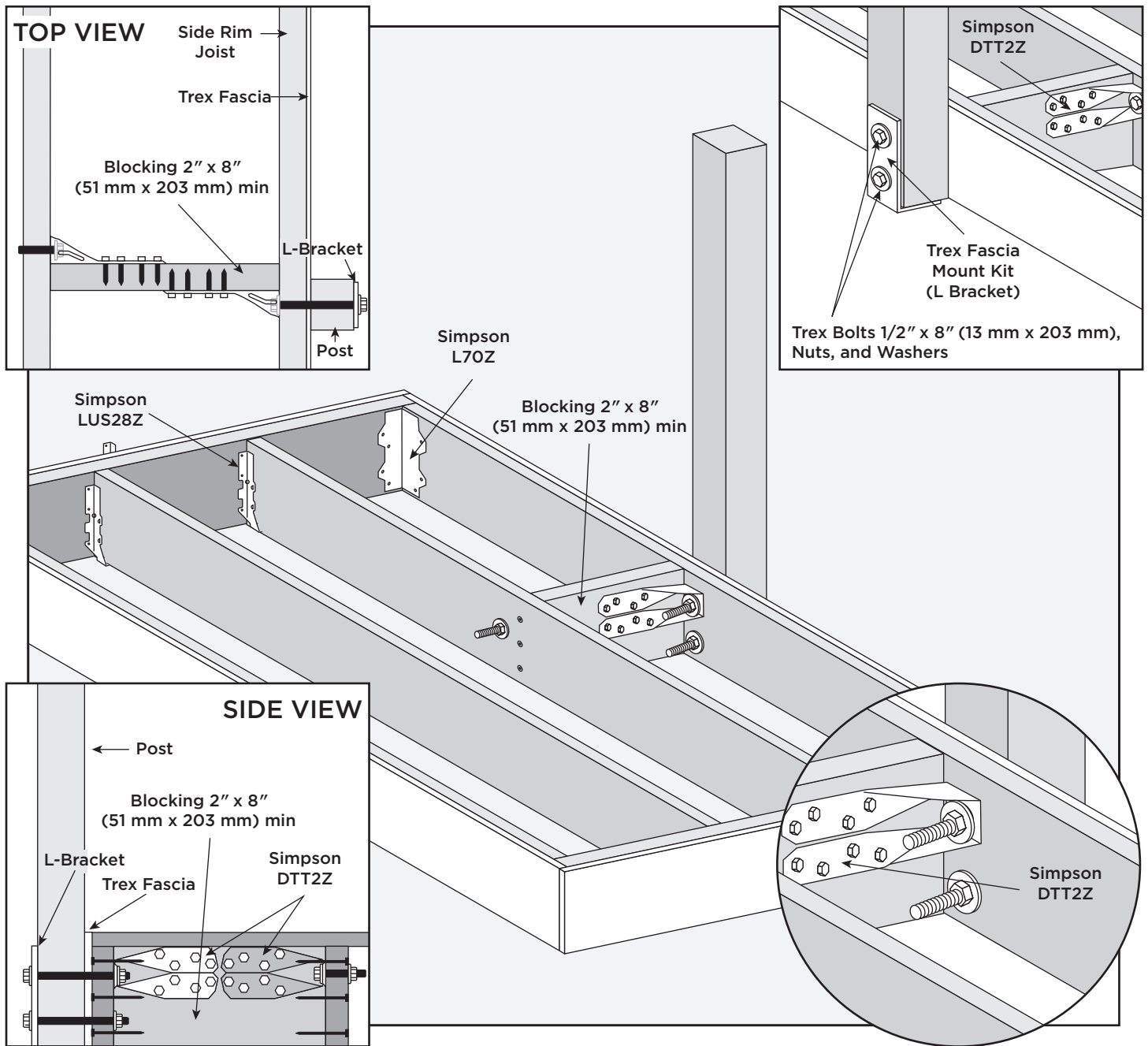

FASCIA MOUNT (OUTSIDE FRAME CORNER)

- » 3/4" (19 MM) FASCIA MUST BE USED, OR BOLTS MUST BE CUT DOWN.
- » INSTALL POST TIGHTLY ON RIM JOIST FIRST - NUTS WILL BE INACCESSIBLE LATER.
- » MUST USE TREX FASCIA MOUNT CORNER BRACKET KIT.

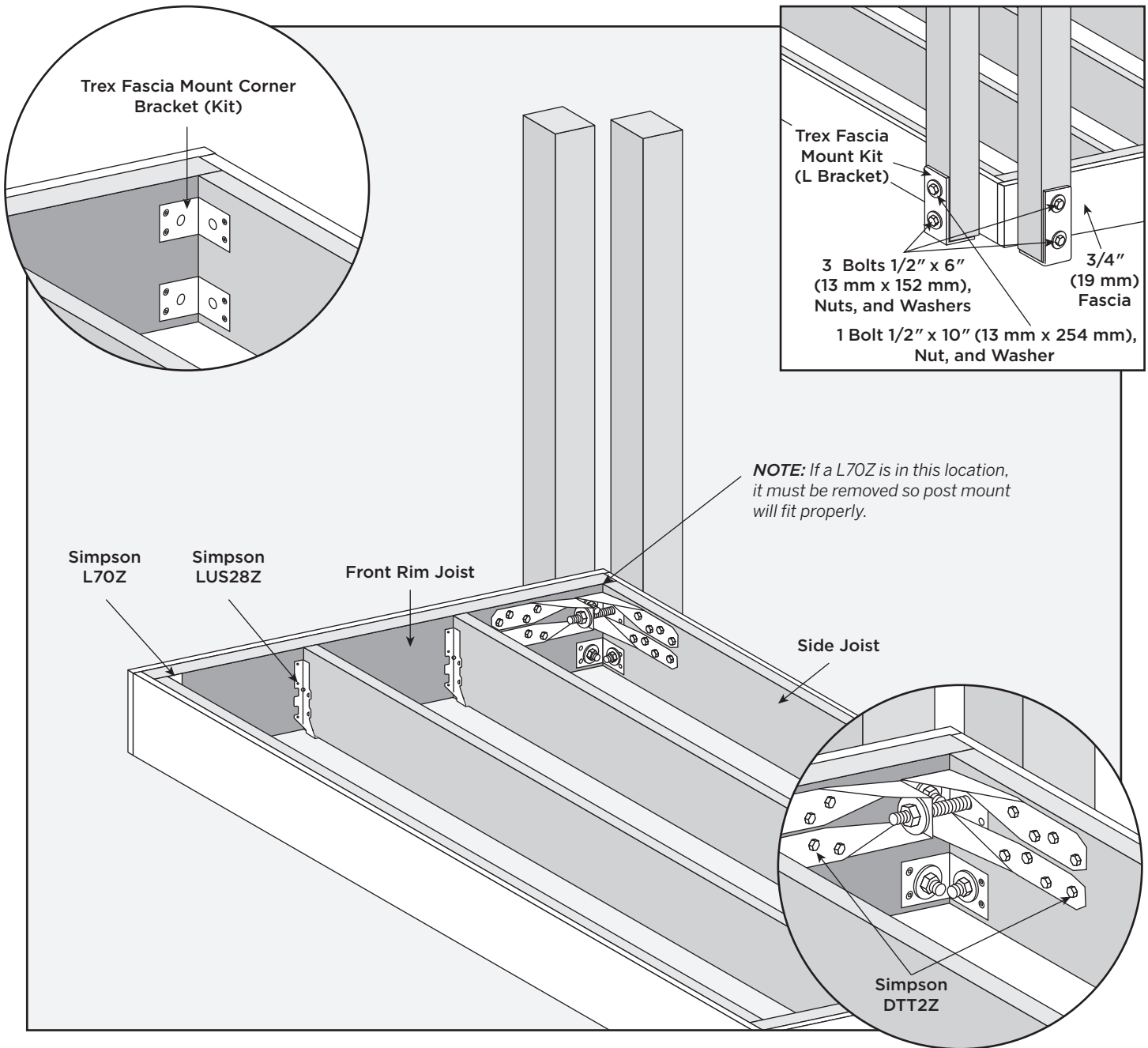

1. Install post on rim joist and fully tighten using Simpson DTT2Z on top bolt.
2. Run 10" (254 mm) bolt through gap in existing Simpson DTT2Z and tighten into second DTT2Z.
3. Install bottom bolt.

TREX SIGNATURE RAILING APPLICATIONS

Installation of Railing

1. All required hardware is included with Trex Signature railing, follow Trex Signature railing instructions for complete installation requirements.

FASCIA MOUNT (OUTSIDE FRAME CORNER)

- » 3/4" (19 MM) FASCIA MUST BE USED, OR BOLTS MUST BE CUT DOWN.
- » INSTALL POST TIGHTLY ON RIM JOIST FIRST - NUTS WILL BE INACCESSIBLE LATER.
- » MUST USE TREX FASCIA MOUNT CORNER BRACKET KIT.

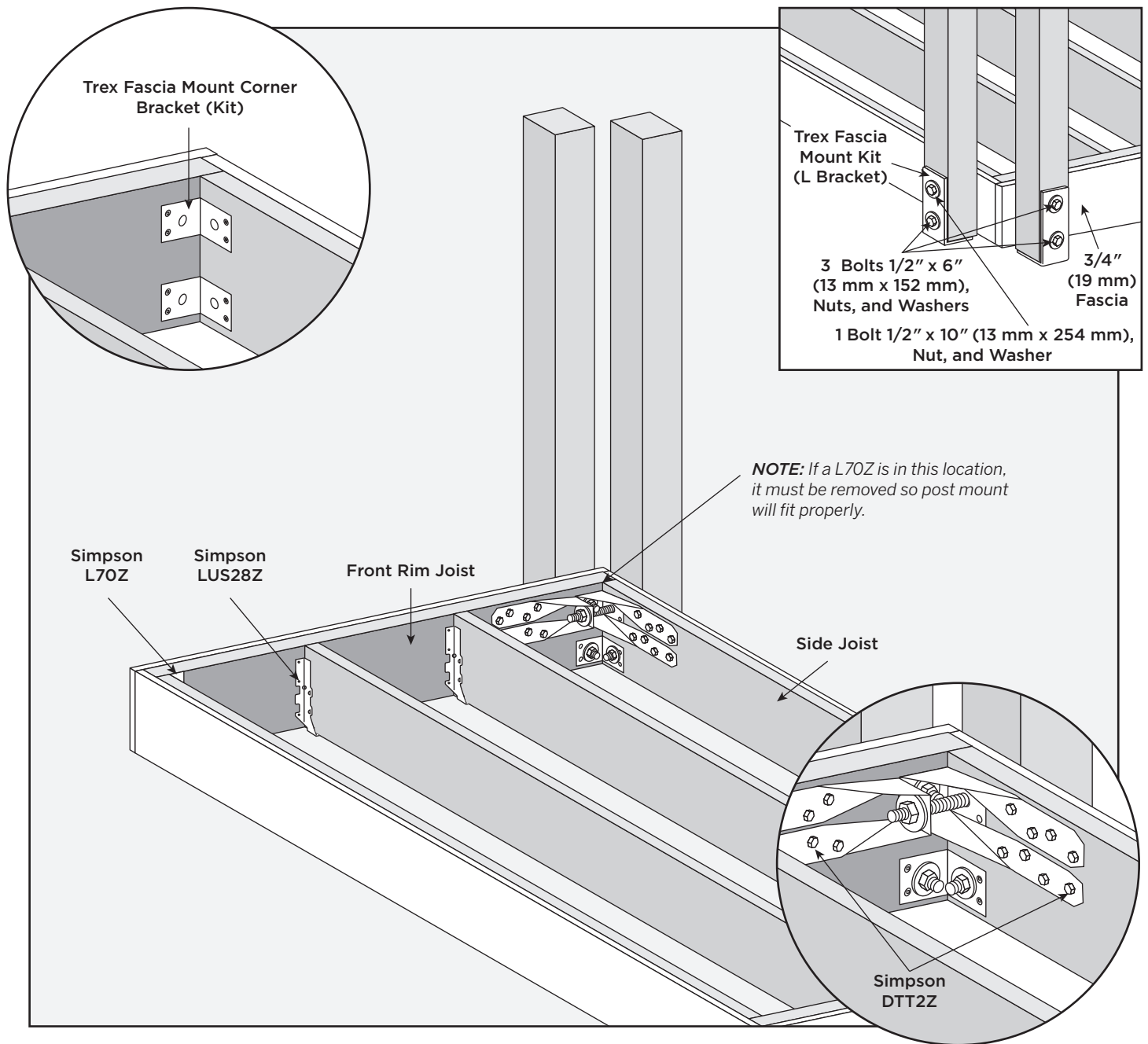

NOTE: If a L70Z is in this location, it must be removed so post mount will fit properly.

1. Install post on rim joist and fully tighten using Simpson DTT2Z on top bolt.
2. Run 10" (254 mm) bolt through gap in existing Simpson DTT2Z and tighten into second DTT2Z.
3. Install bottom bolt.

TREX SIGNATURE RAILING APPLICATIONS

Installation of Railing

1. All required hardware is included with Trex Signature railing, follow Trex Signature railing instructions for complete installation requirements.





RAILING

RAILING— a lot easier than it looks

Selecting the right railing is pretty easy, but each Trex® railing line is a little different. Please read the system descriptions at the top of each product section so you can choose exactly which railing components you need to complete your design. For additional guidance, the chart to the right depicts each railing system's components.

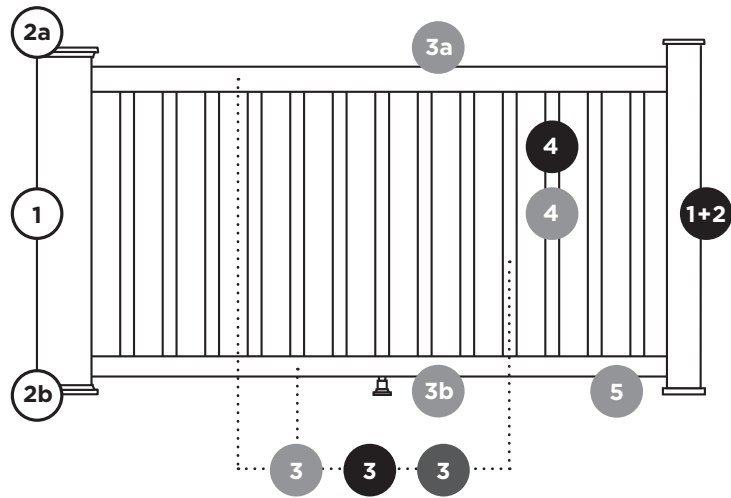

TREX POST COMPONENTS | TREX SIGNATURE RAILING | TREX TRANSCEND RAILING | TREX SELECT RAILING

Trex Post Sleeves, Caps & Skirts

These components can be used as steps 1 & 2 for all Trex railing lines.

STEP	COMPONENT	DESCRIPTION	ITEM NUMBER
1	Post Sleeve Each 4x4 and 6x6 post sleeve fits over a 4x4 pressure treated post or equivalent post mount.	4" x 4" x 39" Post Sleeve <i>[4.45 in x 4.45 in x 40 in (113 mm x 113 mm x 101 cm) external dimensions]</i>	XX040439APS
		4" x 4" x 108" Post Sleeve <i>[4.45 in x 4.45 in x 108 in (113 mm x 113 mm x 274 cm) external dimensions]</i>	XX0404108APS
		6" x 6" x 39" Post Sleeve <i>[5.5 in x 5.5 in x 39 in (139 mm x 139 mm x 990 mm) external dimensions]</i>	WT060639APS
		6" x 6" x 108" Post Sleeve <i>[5.5 in x 5.5 in x 108 in (139 mm x 139 mm x 274 cm) external dimensions]</i>	WT0606108APS
2a	Post Sleeve Cap Also available with LED lighting. See page 13.	Flat 4" x 4" Post Sleeve Cap <i>[4.55 in x 4.55 in (115 mm x 115 mm) internal dimensions]</i>	PXXSQCAP4X4
		Flat 6" x 6" Post Sleeve Cap <i>[5.55 in x 5.55 in (140 mm x 140 mm) internal dimensions]</i>	PWTSQCAP6X6
2b	Post Sleeve Skirt	4" x 4" Post Sleeve Skirt <i>[4.55 in x 4.55 in (115 mm x 115 mm) internal dimensions]</i> 6" x 6" Post Sleeve Skirt <i>[5.55 in x 5.55 in (140 mm x 140 mm) internal dimensions]</i>	PXXSKIRT4X4 PWTSKIRT6X6
ACCESSORY			
	Surface Mount Post For use with 4x4 composite post sleeve	Aluminum Surface Mount Post for 36" (914 mm) Rail Height (1/box) <i>Actual external dimensions of insert: 3.75 in x 3.75 in x 7 in (95 mm x 95 mm x 177 mm)</i>	ALPOSTMOUNT36
		Aluminum Surface Mount Post for 42" (1066 mm) Rail Height (1/box) <i>Actual external dimensions of insert: 3.75 in x 3.75 in x 7 in (95 mm x 95 mm x 177 mm)</i>	ALPOSTMOUNT42
		Surface Mount Post Hardware—Wood (10 kits/box)	ALPOSTHWDECK
	Joist Mount Post For use with 4x4 composite post sleeve	Aluminum Joist Mount Post for use with all Trex railing heights (1/box) <i>Actual external dimensions of insert: 3.75 in x 3.75 in x 7 in (95 mm x 95 mm x 177 mm)</i>	CPJMNTPOST63

XX = COLOR PREFIX

- WT Classic White GP Gravel Path TH Tree House
- BK Charcoal Black RS Rope Swing VL Vintage Lantern

STEP	DESCRIPTION	ITEM NUMBER	DESCRIPTION	ITEM NUMBER
1+2	Aluminum Posts		IRC Aluminum Mounting Plate & Hardware <i>For use with all Trex 2.5" Surface Mount Aluminum Posts</i>	ALPOSTHWDECK
	Can only be used within the Trex Signature line. Trex Signature aluminum posts fulfill steps 1 & 2. If using composite post sleeves, refer to page 50.		Concrete Post Mount Kit	ALPOSTHWCONC
	2.5" x 2.5" x 37" Aluminum Post—Horizontal	XXAL252537RCAP	2.5" x 2.5" x 63" Aluminum Joist Mount Post <i>Comes with cap and skirt.</i>	XXJMNTPOST63
	2.5" x 2.5" x 43" Aluminum Post—Horizontal	XXAL252543RCAP		
	2.5" x 2.5" x 53" Aluminum Post—Stair	XXAL252553RCAP	Trex Signature Fascia Mount Kit - wood framing <i>For use with Joist Mount Trex Signature Railing Post only.</i>	XXFMNTWOOD
	<i>Comes with cap and skirt.</i>			
	2.5" x 2.5" x 36" Crossover Post—Horizontal	XXAL252536RCPP		
	2.5" x 2.5" x 42" Crossover Post—Horizontal	XXAL252542RCPP		
	<i>Comes with skirt.</i>			
	2.5" x 2.5" x 37" Line Post with Premounted Brackets	BKAL252537RCAPLINE		
2.5" x 2.5" x 37" End Post with Premounted Brackets	BKAL252537RCAPEND			
2.5" x 2.5" x 37" Corner Post with Premounted Brackets	BKAL252537RCAPCNR			
2.5" x 2.5" x 43" Line Post with Premounted Brackets	BKAL252543RCAPLINE			
2.5" x 2.5" x 43" End Post with Premounted Brackets	BKAL252543RCAPEND			
2.5" x 2.5" x 43" Corner Post with Premounted Brackets	BKAL252543RCAPCNR			
<i>Comes with cap and skirt.</i>				

Dimensions above are nominals. See below for actuals and metrics.
 [2.5 in x 2.5 in x 36 in (63 mm x 63 mm x 914 mm) actual dimensions]
 [2.5 in x 2.5 in x 37 in (63 mm x 63 mm x 939 mm) actual dimensions]
 [2.5 in x 2.5 in x 42 in (63 mm x 63 mm x 106 cm) actual dimensions]
 [2.5 in x 2.5 in x 43 in (63 mm x 63 mm x 109 cm) actual dimensions]
 [2.5 in x 2.5 in x 53 in (63 mm x 63 mm x 134 cm) actual dimensions]
 [2.5 in x 2.5 in x 63 in (63 mm x 63 mm x 160 cm) actual dimensions]

STEP	DESCRIPTION	ITEM NUMBER	DESCRIPTION	ITEM NUMBER
3	Rail & Baluster Kit		6' x 36" Rail Kit w. Square Balusters—Horizontal	XXAS0636HRK
	<i>(includes top rail, bottom rail, balusters and mounting and support hardware)</i>		6' x 36" Rail Kit w. Square Balusters—Stair	XXAS0636SRK
	<i>Available in WT, BZ, and BK.</i>		8' x 36" Rail Kit w. Square Balusters—Horizontal	XXAS0836HRK
	6' x 36" Rail Kit w. Round Balusters—Horizontal	BKAR0636HRK	8' x 36" Rail Kit w. Square Balusters—Stair	XXAS0836SRK
	6' x 36" Rail Kit w. Round Balusters—Stair	BKAR0636SRK	6' x 42" Rail Kit w. Square Balusters—Horizontal	XXAS0642HRK
	8' x 36" Rail Kit w. Round Balusters—Horizontal	BKAR0836HRK	6' x 42" Rail Kit w. Square Balusters—Stair	XXAS0642SRK
	8' x 36" Rail Kit w. Round Balusters—Stair	BKAR0836SRK	8' x 42" Rail Kit w. Square Balusters—Horizontal	XXAS0842HRK
	6' x 42" Rail Kit w. Round Balusters—Horizontal	BKAR0642HRK	8' x 42" Rail Kit w. Square Balusters—Stair	XXAS0842SRK
	6' x 42" Rail Kit w. Round Balusters—Stair	BKAR0642SRK	4' x 36" Assembled Panel (Square)—Horizontal	BKAS0436HRPNL
	8' x 42" Rail Kit w. Round Balusters—Horizontal	BKAR0842HRK	6' x 36" Assembled Panel (Square)—Horizontal	BKAS0636HRPNL
8' x 42" Rail Kit w. Round Balusters—Stair	BKAR0842SRK	8' x 36" Assembled Panel (Square)—Horizontal	BKAS0836HRPNL	
		4' x 42" Assembled Panel (Square)—Horizontal	BKAS0442HRPNL	
		6' x 42" Assembled Panel (Square)—Horizontal	BKAS0642HRPNL	
		8' x 42" Assembled Panel (Square)—Horizontal	BKAS0842HRPNL	

Dimensions above are nominals. See below for actuals and metrics.
 [4' x 36": 48 in x 36 in (122 cm x 914 mm) actual dimensions]
 [6' x 36": 72 in x 36 in (182 cm x 914 mm) actual dimensions]
 [8' x 36": 96 in x 36 in (243 cm x 914 mm) actual dimensions]
 [4' x 42": 48 in x 42 in (122 cm x 106 cm) actual dimensions]
 [6' x 42": 72 in x 42 in (182 cm x 106 cm) actual dimensions]
 [8' x 42": 96 in x 42 in (243 cm x 106 cm) actual dimensions]

Does not include hardware.

STEP	DESCRIPTION	ITEM NUMBER	DESCRIPTION	ITEM NUMBER
3	Rail & Rod Kit		6' x 42" Black Rails & Black Rods Kit—Horizontal	BKBKROD0642HRK
	<i>(includes top rail, bottom rail, rods and mounting and support hardware)</i>		6' x 42" Black Rails & Black Rods Kit—Stair	BKBKROD0642SRK
	6' x 36" Black Rails & Platinum Rods Kit—Horizontal	BKPLROD0636HRK	8' x 42" Black Rails & Black Rods Kit—Horizontal	BKBKROD0842HRK
	6' x 36" Black Rails & Platinum Rods Kit—Stair	BKPLROD0636SRK	8' x 42" Black Rails & Black Rods Kit—Stair	BKBKROD0842SRK
	8' x 36" Black Rails & Platinum Rods Kit—Horizontal	BKPLROD0836HRK	36" Rod Rail Vertical Kit—Horizontal	XX36RODHVERTK
	8' x 36" Black Rails & Platinum Rods Kit—Stair	BKPLROD0836SRK	36" Rod Rail Vertical Kit—Stair	XX36RODSVERTK
	6' x 36" Bronze Rails & Platinum Rods Kit—Horizontal	BZPLROD0636HRK	42" Rod Rail Vertical Kit—Horizontal	XX42RODHVERTK
	6' x 36" Bronze Rails & Platinum Rods Kit—Stair	BZPLROD0636SRK	42" Rod Rail Vertical Kit—Stair	XX42RODSVERTK
	8' x 36" Bronze Rails & Platinum Rods Kit—Horizontal	BZPLROD0836HRK	<i>Use as an accessory for cut rod rail sections.</i>	
	8' x 36" Bronze Rails & Platinum Rods Kit—Stair	BZPLROD0836SRK	<i>Available in BK and PL.</i>	
6' x 36" Black Rails & Black Rods Kit—Horizontal	BKBKROD0636HRK	Dimensions above are nominals. See below for actuals and metrics.		
6' x 36" Black Rails & Black Rods Kit—Stair	BKBKROD0636SRK	[6' x 36": 72 in x 36 in (182 cm x 914 mm) actual dimensions]		
8' x 36" Black Rails & Black Rods Kit—Horizontal	BKBKROD0836HRK	[8' x 36": 96 in x 36 in (243 cm x 914 mm) actual dimensions]		
8' x 36" Black Rails & Black Rods Kit—Stair	BKBKROD0836SRK	[6' x 42": 72 in x 42 in (182 cm x 106 cm) actual dimensions]		
6' x 42" Black Rails & Platinum Rods Kit—Horizontal	BKPLROD0642HRK	[8' x 42": 96 in x 42 in (243 cm x 106 cm) actual dimensions]		
6' x 42" Black Rails & Platinum Rods Kit—Stair	BKPLROD0642SRK			
8' x 42" Black Rails & Platinum Rods Kit—Horizontal	BKPLROD0842HRK			
8' x 42" Black Rails & Platinum Rods Kit—Stair	BKPLROD0842SRK			
6' x 42" Bronze Rails & Platinum Rods Kit—Horizontal	BZPLROD0642HRK			
6' x 42" Bronze Rails & Platinum Rods Kit—Stair	BZPLROD0642SRK			
8' x 42" Bronze Rails & Platinum Rods Kit—Horizontal	BZPLROD0842HRK			
8' x 42" Bronze Rails & Platinum Rods Kit—Stair	BZPLROD0842SRK			

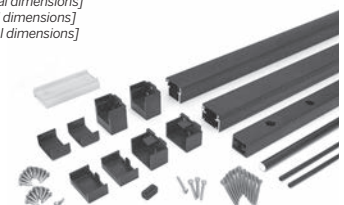

XX = COLOR PREFIX

- WT Classic White
- BZ Bronze
- BK Charcoal Black
- PL Platinum

NOTE: Construction methods are always improving. Please refer to www.trex.com for the most up-to-date installation requirements.

Choose either aluminum posts or composite post sleeves, caps and skirts for steps 1 & 2.
Pair with a rail kit (step 3) and infill panel (step 4) if needed.

STEP	COMPONENT	DESCRIPTION	ITEM NUMBER
3	Mesh Rail Kit (includes top rail, bottom rail, foot block, verticals, anti-rattle gaskets, hardware and bracket pack) 	6' x 36" Mesh Railing Kit—Horizontal 6' x 36" Mesh Railing Kit—Stair 8' x 36" Mesh Railing Kit—Horizontal 8' x 36" Mesh Railing Kit—Stair 6' x 42" Mesh Railing Kit—Horizontal 6' x 42" Mesh Railing Kit—Stair 8' x 42" Mesh Railing Kit—Horizontal 8' x 42" Mesh Railing Kit—Stair	XXA0636PNLHRK XXA0636PNLSRK XXA0836PNLHRK XXA0836PNLSRK XXA0642PNLHRK XXA0642PNLSRK XXA0842PNLHRK XXA0842PNLSRK
		36" Mesh Railing Vertical Kit—Horizontal 36" Mesh Railing Vertical Kit—Stair 42" Mesh Railing Vertical Kit—Horizontal 42" Mesh Railing Vertical Kit—Stair Use as an accessory for cut mesh railing sections.	XX36MSHHVERTK XX36MSHSVVERTK XX42MSHHVERTK XX42MSHSVVERTK
Available in BK and BZ. Mesh infill sold separately. Dimensions above are nominals. See below for actuals and metrics. [6' x 36": 72 in x 36 in (182 cm x 914 mm) actual dimensions] [8' x 36": 96 in x 36 in (243 cm x 914 mm) actual dimensions] [6' x 42": 72 in x 42 in (182 cm x 106 cm) actual dimensions] [8' x 42": 96 in x 42 in (243 cm x 106 cm) actual dimensions]			

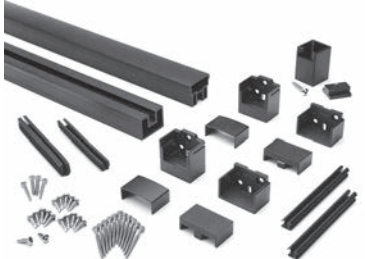
Glass Rail Kit (includes top rail, bottom rail, foot block, verticals, hardware and bracket pack) 	6' Glass Railing Kit—Horizontal	XXA06HGLRK
	Available in BK and WT. Glass infill not included. Utilizes readily available 1/4" tempered glass. Glass can be sourced by contacting your local glazier or call 1-800 BUY-TREX for more information. Dimension above is nominal. See below for actual and metric. [6': 72 in (182 cm) actual dimension]	

4 Mesh Panel (includes stainless steel mesh panel) For use with Trex Signature Mesh Kit.		6' x 36" Stainless Steel Mesh Panel—Horizontal 8' x 36" Stainless Steel Mesh Panel—Horizontal 8' x 42" Stainless Steel Mesh Panel—Horizontal Universal 316 Stainless Steel Mesh Panel—Stair	SSMESH0636HZ SSMESH0836HZ SSMESH0842HZ SSMESHUNIVST
	Dimensions above are nominals. See below for actuals and metrics. [6' x 36": 64 in x 32.375 in (162 cm x 822 mm) actual dimensions] [8' x 36": 88 in x 32.375 in (223 cm x 822 mm) actual dimensions] [8' x 42": 88 in x 38.375 in (223 cm x 974 mm) actual dimensions] [Universal 316: 108.1875 in x 36.1875 in (274 cm x 919 mm) actual dimensions]		

DESCRIPTION	ITEM NUMBER	DESCRIPTION	ITEM NUMBER
ACCESSORY		Cocktail Rail Bracket (10/pack)	XXCTBKAL10PK
Trex Signature Bracket Templates Bracket Template—Horizontal (36" and 42") - Composite Sleeve Bracket Template—Horizontal (36" and 42") - 2.5" Aluminum Post 	SIGTEMP4X4SLEEVE	Fixed Bracket—Horizontal (4/pack)	XXFHBKTAL
	SIGTEMPIRCPOST	Fixed Bracket—Stair (4/pack)	XXFSBKAL
		Tabless Fixed Bracket—Horizontal (4/pack)	XXFHBKTALPNL
		Swivel Bracket—Horizontal (2/pack—1 top, 1 bottom)	XXSWHBKTAL
		Swivel Bracket—Stair (2/pack—1 top, 1 bottom)	XXSWSBKAL
		2.5" Crossover Bracket—Horizontal (1/pack)	XX25FHCBKAL
		2.5" Swivel Crossover Bracket—Stair (1/pack)	XX25RCSWSCBKAL
		Compound Swivel Bracket (2/pack—1 top, 1 bottom)	XXCPDSWBKTAL
		Aluminum Foot Block	XXALFTBLK
		Touch-up Pen	XXTOUCHUPPEN

XX = COLOR PREFIX

WT Classic White BZ Bronze BK Charcoal Black SS Stainless Steel

NOTE: Construction methods are always improving. Please refer to www.trex.com for the most up-to-date installation requirements.

Trex Transcend® Railing

Transcend is either a 3-step or 5-step process. Choose Trex post sleeves, caps and skirts (steps 1 & 2), then choose a rail kit (step 3). OR choose each component individually for a custom design (steps 3a, 3b, 4 & 5).

STEP	COMPONENT	DESCRIPTION	ITEM NUMBER	COLOR
3	Rail & Square Composite Baluster Kit <i>(includes Crown top rail, Universal bottom rail, square composite balusters, baluster spacers, adjustable foot block and mounting hardware)</i> <i>Color option indicates rails and balusters.</i>	6' x 36" Rail & Baluster Kit—Horizontal	XX0636HRK	WT, BK, VL
		6' x 36" Rail & Baluster Kit—Stair	WT0636SRK	WT
		8' x 36" Rail & Baluster Kit—Horizontal	XX0836HRK	WT, BK, VL
		8' x 36" Rail & Baluster Kit—Stair	XX0836SRK	WT, BK, VL
		6' x 42" Rail & Baluster Kit—Horizontal	XX0642HRK	WT, BK, VL
		8' x 42" Rail & Baluster Kit—Horizontal	XX0842HRK	WT, BK, VL
		8' x 42" Rail & Baluster Kit—Stair	XX0842SRK	WT, BK, VL



	Rail & Round Aluminum Baluster Kit <i>(includes Crown top rail, Universal bottom rail, round aluminum balusters, baluster spacers, adjustable foot block and mounting hardware)</i> <i>Color option indicates rails. Round aluminum balusters come in BK.</i>	6' x 36" Rail & Baluster Kit—Horizontal	XXRD0636HRK	WT, BK, VL
		8' x 36" Rail & Baluster Kit—Horizontal	XXRD0836HRK	WT, BK, VL
		8' x 36" Rail & Baluster Kit—Stair	XXRD0836SRK	WT, BK, VL
		6' x 42" Rail & Baluster Kit—Horizontal	XXRD0642HRK	WT, BK, VL
		8' x 42" Rail & Baluster Kit—Horizontal	XXRD0842HRK	WT, BK, VL
		8' x 42" Rail & Baluster Kit—Stair	XXRD0842SRK	WT, BK, VL



	Cocktail Rail & Round Aluminum Baluster Kit <i>(includes Universal top/bottom rails, round aluminum balusters, baluster spacers, adjustable foot block and mounting hardware)</i> <i>Round aluminum balusters come in BK. Only Trex Transcend and Select deck boards can be used for cocktail rail application.</i>	6' x 36" Cocktail Rail & Baluster Kit—Horizontal	WTRD0636HRKCKTL	WT
		8' x 36" Cocktail Rail & Baluster Kit—Horizontal	WTRD0836HRKCKTL	WT
		8' x 36" Cocktail Rail & Baluster Kit—Stair	WTRD0836SRKCKTL	WT

Dimensions above are nominals. See below for actuals and metrics.
 6' x 36": 67.5 in x 36 in (171 cm x 914 mm) 8' x 36": 91.5 in x 36 in (232 cm x 914 mm)
 6' x 42": 67.5 in x 42 in (171 cm x 106 cm) 8' x 42": 91.5 in x 42 in (232 cm x 106 cm)



OR choose each component individually for a custom design (steps 3a, 3b, 4 & 5).

STEP	COMPONENT	DESCRIPTION	ITEM NUMBER
3a	Top Rail Universal top rail is used for cocktail rail applications.	6' Crown Top Rail	XXCROWNTR06
		8' Crown Top Rail	XXCROWNTR08
		6' Universal Top/Bottom Rail	XXUNIVTBR06
		8' Universal Top/Bottom Rail	XXUNIVTBR08
3b	Bottom Rail	6' Universal Top/Bottom Rail	XXUNIVTBR06
		8' Universal Top/Bottom Rail	XXUNIVTBR08

[6' Rail: 67.5 in (171 cm) actual length; 8' Rail: 91.5 in (232 cm) actual length]



4	Balusters See chart below for number of balusters needed to complete each railing section.	Square Composite Balusters for 36" Rail Height (16/pack)	XX020230SBK
		Square Composite Balusters for 42" Rail Height (16/pack)	XX020236SBK
		Round Aluminum Balusters for 36" Rail Height (20/pack)	XXTA30RBK
		Round Aluminum Balusters for 42" Rail Height (20/pack)	XXTA36RBK

BALUSTER	ORIENTATION	6' SECTION	8' SECTION
Square composite	Horizontal	13	18
	Stair	11	15
Round aluminum	Horizontal	15	20
	Stair	12	16

Aluminum balusters are only available in BK, WT, BZ.

Dimensions above are nominals. See below for actuals and metrics.
 6' Rail: 67.5 in (171 cm)
 8' Rail: 91.5 in (232 cm)
 Composite 36" Baluster: 1.418 in x 1.418 in x 30.375 in (36 mm x 36 mm x 771 mm)
 Composite 42" Baluster: 1.418 in x 1.418 in x 36.375 in (36 mm x 36 mm x 923 mm)
 Aluminum 36" Baluster: .75 in x 30.25 in (19 mm x 768 mm)
 Aluminum 42" Baluster: .75 in x 36.25 in (19 mm x 920 mm)



XX = COLOR PREFIX

Composite Colors

WT Classic White GP Gravel Path TH Tree House
 BK Charcoal Black RS Rope Swing VL Vintage Lantern

Aluminum Colors

WT Classic White BK Charcoal Black
 BZ Bronze

Trex Transcend® Railing

STEP	COMPONENT	DESCRIPTION	ITEM NUMBER
5	Accessory Infill Kit <i>(includes, baluster spacers, adjustable foot block and mounting hardware)</i>	6' Accessory Infill Kit for Square Composite Balusters—Horizontal	XXSQHIK06
		6' Accessory Infill Kit for Square Composite Balusters—Stair	XXSQSIK06
		8' Accessory Infill Kit for Square Composite Balusters—Horizontal	XXSQHIK08
		8' Accessory Infill Kit for Square Composite Balusters—Stair	XXSQSIK08
		6' Accessory Infill Kit for Round Aluminum Balusters—Horizontal	XXRDHIK06
		6' Accessory Infill Kit for Round Aluminum Balusters—Stair	XXRDSIK06
		8' Accessory Infill Kit for Round Aluminum Balusters—Horizontal	XXRDHIK08
		8' Accessory Infill Kit for Round Aluminum Balusters—Stair	XXRDSIK08
		6' Glass Panel Accessory Infill Kit	XXGLIK06

Dimensions above are nominals. See below for actuals and metrics.
 6': 67.5 in (171 cm)
 8': 91.5 in (232 cm)

DESCRIPTION	ITEM NUMBER	DESCRIPTION	ITEM NUMBER
ACCESSORY			
Trex Transcend Bracket Template Bracket Template—Horizontal (36" and 42") - Composite Sleeve	TSCTEMP4X4SLEEVE	Mounting Hardware for Cut Rails—Horizontal	XXHZACCYKIT
Foot Block	XXFTBLKPC	Mounting Hardware for Cut Rails—Stair	XXSTACCYKIT
		Transcend RSB Bracket Pack—Horizontal (24/box)	TSHBRACKET
		Transcend RSB Bracket Pack—Stair (24/box)	TSSBRACKET
		0 Degree Rail Gasket Pack—Horizontal	XX00HGASK
		0 Degree Rail Gasket Pack—Stair	XX00SGASK
		22.5 Degree Gasket Pack	XX22HGASK
		45 Degree Birdsmouth Gasket Pack (for 4x4)	XX45RSBADAPK
		45 Degree Gasket Pack (for 6x6)	WT45HGASK

Trex Select® Railing

Trex Select is a 3-step process. Choose Trex post sleeves, caps and skirts (steps 1 & 2) and a rail kit (step 3).

STEP	COMPONENT	DESCRIPTION	ITEM NUMBER
3	Rail & Round Aluminum Baluster Kit <i>(includes top rail, bottom rail, round aluminum balusters, adjustable foot block and hardware pack)</i>	6' x 36" Rail & Baluster Kit—Horizontal	WTRD0636HSELK
		6' x 36" Rail & Baluster Kit—Stair	WTRD0636SSELK
		8' x 36" Rail & Baluster Kit—Horizontal	WTRD0836HSELK
		8' x 36" Rail & Baluster Kit—Stair	WTRD0836SSELK
		6' x 42" Rail & Baluster Kit—Horizontal	WTRD0642HSELK
		8' x 42" Rail & Baluster Kit—Horizontal	WTRD0842HSELK
		8' x 42" Rail & Baluster Kit—Stair	WTRD0842SSELK

Available in WT rails with aluminum balusters in BK.

Dimensions above are nominals. See below for actuals and metrics.
 6' x 36": 67.5 in x 36 in (171 cm x 914 mm)
 6' x 42": 67.5 in x 42 in (171 cm x 1066 mm)
 8' x 36": 91.5 in x 36 in (232 cm x 914 mm)
 8' x 42": 91.5 in x 42 in (232 cm x 1066 mm)

ACCESSORY	Mounting Hardware for Cut Rails—Horizontal (10 kits/box)		BKENHZBKT
	Mounting Hardware for Cut Rails—Stair (10 kits/box)		BKENSTBKT
	Trex Select 8' Aluminum Rail Stiffener		SELALRAILSTIFFENER

XX = COLOR PREFIX

Composite Colors

WT Classic White	GP Gravel Path	TH Tree House
BK Charcoal Black	RS Rope Swing	VL Vintage Lantern

Aluminum Colors

WT Classic White	BK Charcoal Black
BZ Bronze	

Trex Aluminum ADA Compliant Handrail

COMPONENT	ITEM NUMBER
1.375 in x 8 ft (34 mm x 243 cm) Hand Rail	XXALADARAIL8
Wall Return 90°	XXALADA90WR2G
Wall Mount	XXALADAWMNT2G
Corner Mount	XXALADAICORNER2G
Post Return ("Candy Cane")	XXALADA18OCCANE
5° Elbow	XXALADA05ELB
31° Elbow	XXALADA31ELB
34° Elbow	XXALADA34ELB
36° Elbow	XXALADA36ELB
90° Inside/Outside Elbow	XXALADA90ELB2G
Adjustable ADA Elbow	XXALADAADJELB
Straight 4 in (101 mm) Internal Connector	XXALINTCONN
Inline Rail Termination Adapter	XXALADAINLINE
Rail End Cap	XXALADACAP
Aluminum Collar	XXALADACL



All Trex ADA handrail components are made of powder-coated aluminum. For detailed installation instructions, visit trex.com/2021

- 1 36° Elbow
- 2 Wall Mount
- 3 Aluminum Collar



- 4 Wall Return 90°
- 5 Hand Rail



Trex Aluminum Gates

COMPONENT	DESCRIPTION	ITEM NUMBER
Gate Rail Kit Available in all aluminum colors (Charcoal Black, Bronze and Classic White). When ordering, refer to prefix codes at the bottom of this page.	36" Rail Height, Square Balusters, Adjustable up to 48" wide opening	XX36SQADJGATE
	36" Rail Height, Round Balusters, Adjustable up to 48" wide opening	XX36RDADJGATE
	42" Rail Height, Square Balusters, Adjustable up to 48" wide opening	XX42SQADJGATE
	42" Rail Height, Round Balusters, Adjustable up to 48" wide opening	XX42RDADJGATE
	<i>[Actual height 36" Rail: 36 in (914 mm); 42" Rail: 42 in (106 cm) Actual width is 47.5 in (120 cm) but can be cut to fit any width.]</i>	
Hardware Pack 	2 Adjustable Self-Closing Hinges	BKGATEHW
	1 Locking Hasp With Keys	
	Hardware for attachment to wood post with composite sleeve or aluminum posts	



XX = COLOR PREFIX

WT Classic White BZ Bronze BK Charcoal Black

TREX TRANSCEND® HORIZONTAL RAILING

NOTES:

- » TREX TRANSCEND RAILINGS ARE DESIGNED TO BE INSTALLED OVER THE DECKING FRAME OR ON INSIDE OF RIM JOIST. NOTCHING OF PRESSURE-TREATED POSTS OR POSTS INSTALLED ON OUTSIDE OF RIM JOIST IS NOT ALLOWED.
- » All Trex Transcend railing lengths are manufactured at ON CENTER dimensions (spanning from center of each post): 67-5/8" (1718 mm) for 6' (1.83 m) on center, and 91-5/8" (2353 mm) for 8' (2.44 m) on center. Note that railings are designed to be slightly longer than required to allow for very slight play in post placement - some minimal trimming may be required. IT IS VERY IMPORTANT TO MEASURE FIRST.

Care and Cleaning

Maintaining the appearance of your Trex Transcend railing is important. Occasional washing is recommended. Over time your railing may show signs of weathering as a result of exposure to the elements. The frequency of cleaning will depend on the environment and exposure to various types of elements.

- » Clean railing with standard cleaning vinegar or mild soap and water.
- » For more detailed cleaning recommendations, please refer to the Trex Railing Care and Cleaning guide found on www.trex.com.

PARTS

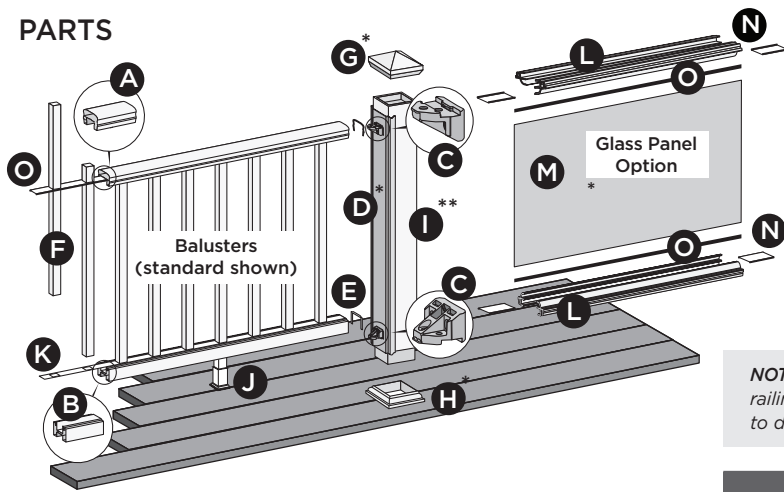

BALUSTER OPTIONS



NOTE: Pictorial representations shown may only show one style of railing, while others may also be used. Review detailed instructions to determine what railing styles and combinations can be used.

DETERMINING BALUSTERS NEEDED

Baluster Type	Per 6' OC Section	Per 8' OC Section
Standard (Horizontal Application)	13	18
Round/Square Aluminum (Horizontal Application)	15	20

NOTES:

- » Basic installation for balusters is the same for all options. When using round or square aluminum balusters, use correct baluster spacers.
- » If installing 42" (1067 mm) railing, use longer post sleeves and measure accordingly to ensure a proper cut. DO NOT CUT TO ACTUAL 42" LENGTH WITHOUT CONFIRMING WHAT STYLE OF RAILING YOU ARE INSTALLING.
- » Ensure pressure-treated posts are installed at proper heights so when post sleeves are installed, both the PT post and post sleeve are flush at top.
- » If using post mounts, refer to detailed instructions provided with post mounts for attaching these prior to installation of any railing type.

- A. Crown or Universal Rail
- B. Universal Rail
- C. Railing Support Bracket (RSB)
- D. TrexExpress™ Railing Assembly Template*
- E. Rail gaskets
- F. Balusters
- G. Post sleeve cap*
- H. Post sleeve skirt*
- I. Post sleeve - 4" x 4" (102 mm x 102 mm) or 6" x 6" (152 mm x 152 mm)**
- J. Adjustable foot block (quantity of one is required for all railing span lengths)***
- K. Baluster spacer

Trex Transcend Glass Panel Parts List

- L. Panel support molding
- M. Tempered glass panel*
- N. Panel support molding spacer
- O. Weather-stripping

* Item not included in the Transcend railing kits.

** Both 4" x 4" (102 mm x 102 mm) and 6" x 6" (152 mm x 152 mm) post sleeves are designed to fit over 4x4 pressure-treated post.

*** For commercial applications, spans over 6' will require two foot blocks. One will be included in kit, a second one will need to be purchased separately.

Screws Supplied with RSB

- C1. Wood screw for attachment of RSB to wood post/composite sleeve
- C2. Self-drilling screw for attachment of RSB to rail

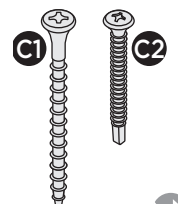

TREX TRANSCEND® HORIZONTAL RAILING

RAILING CONFIGURATIONS

Note: See specific installation instructions for attachment of Trex post mounts or Trex Joist Mount Posts prior to installing any railing.

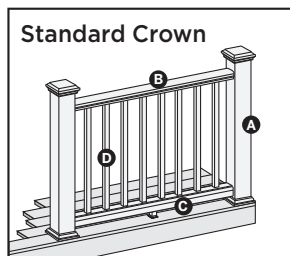

- Cutting post sleeves is **NOT** required.
- A. Pressure-treated post/Trex post sleeve, Trex post mount/Trex post sleeve, or Joist Mount Post/Trex post sleeve (INSIDE MOUNT ONLY)
 - B. Crown rail
 - C. Universal bottom rail
 - D. Trex balusters
- See page 58 for "How to Install Standard Railing".

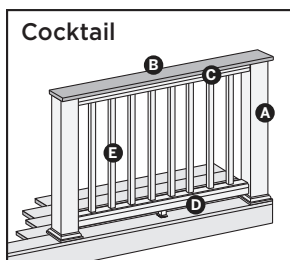

- Post sleeves **WILL NEED TO BE CUT.**
- A. Pressure-treated post with Trex post sleeve
- NOTE:** » Only for use with 4" x 4" (102 mm x 102 mm) post sleeve.
 » Trex post mounts cannot be used with Transcend cocktail design.
- B. Deck board top rail (1 x 6 or 2 x 6). **NOTE:** Enhance cannot be used.
 - C. Universal top rail
 - D. Universal bottom rail
 - E. Trex balusters
- See page 60 for "How to Install Cocktail Railing".
NOTE: Additional pan head screws will need to be purchased - see detailed instructions.

POST SLEEVES WILL NEED TO BE CUT

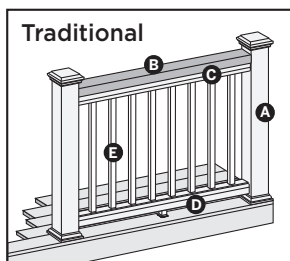

- Cutting post sleeves is **NOT** required.
- A. Pressure-treated post/Trex post sleeve, Trex post mount/Trex post sleeve, or Joist mount post/Trex post sleeve (INSIDE MOUNT ONLY)
 - B. 2 x 4 top rail
 - C. Universal top rail
 - D. Universal bottom rail
 - E. Trex balusters
- See page 61 for "How to Install Traditional Railing".
NOTE: Additional pan head screws will need to be purchased - see detailed instructions.

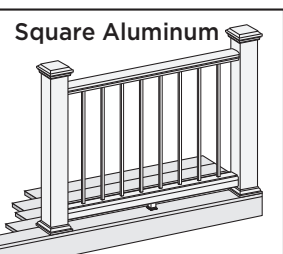
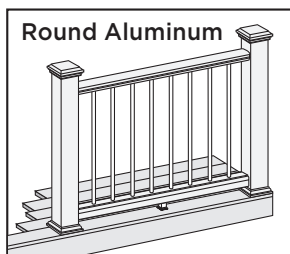

- » Follow desired railing style instructions found above, substituting correct baluster spacer for type of baluster being used.
- » Refer to detailed instructions for added steps when using round and square aluminum balusters. See page 62.

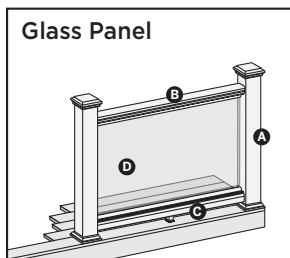

- Cutting post sleeves is **NOT** required.
- A. Pressure-treated post/Trex post sleeve, Trex post mount/Trex post sleeve, or Joist mount post/Trex post sleeve (INSIDE MOUNT ONLY)
 - B. Crown rail (use universal rail if building cocktail or traditional design with glass inserts)
 - C. Universal bottom rail
 - D. Tempered glass panel (**NOT** included in kit)
- See page 63 for "How to Install Standard Glass Panel Railing", page 65 for "How to Install Cocktail Style Glass Panel Railing" (**NOTE: Trex Post Mounts or Trex Joist Mount Posts cannot be used with this railing configuration), and page 66 for "How to Install Traditional Style Glass Panel Railing"

NOTE: Construction methods are always improving. Please refer to www.trex.com for the most up-to-date installation requirements.

HOW TO INSTALL STANDARD HORIZONTAL RAILING

TREX TRANSCEND®

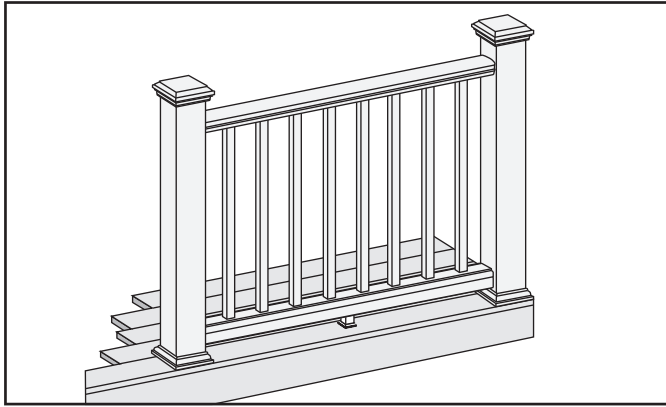

Installing Railing Support Brackets (RSBs)

Option 1: Without TrexExpress railing template:

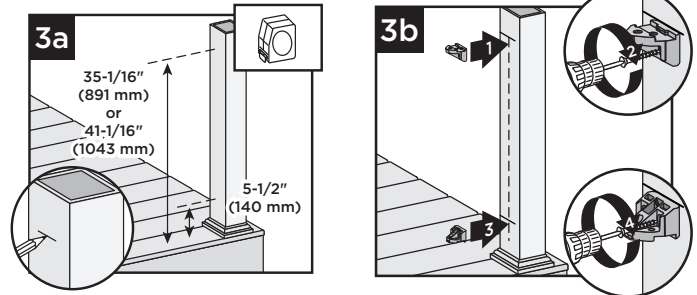

Read all instructions **BEFORE** installation.

Important: Post sleeves are **NOT** to be cut for this design style.

1. Installing Pressure-Treated Posts

» Please refer to local building code requirements prior to attaching pressure treated posts. Below instructions are guidelines for general requirements.

- » Posts are to be installed 6' (1.83 m) or 8' (2.44 m) on center to accommodate appropriate railing length.
- » Attach posts using 1/2" (130 mm) carriage bolts.
- » Minimum joist size is 2" x 8" (51 mm x 203 mm).
- » Top bolts must be 1" (25 mm) from tops of joists.
- » Bottom bolts must be 5-1/8" (130 mm) from top bolts.
- » Bolts can be countersunk flush with framing to allow for fascia attachment.

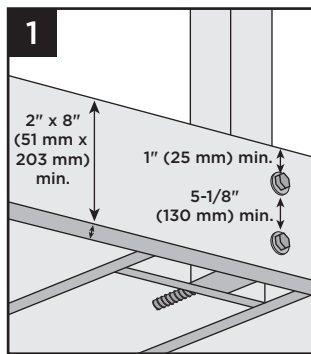

3a. Mark 5-1/2" (140 mm) and 35-1/16" (891 mm) from deck surface **OR** for 42" (1067 mm) height, mark 5-1/2" (140 mm) and 41-1/16" (1043 mm) from the deck surface.

3b. Place RSBs directly under marks, center on posts, and secure with 2" (51 mm) wood screws (provided). **Place top RSBs flat side up, bottom RSBs flat side down.**

6X6 POST SLEEVE NOTES:

- » 6x6 post sleeve is designed to fit over 4x4 pressure-treated post.
- » When using a 6x6 post sleeve, secure RSB's to post with 2 1/2" (64mm) wood screws provided with the 6x6 post sleeve.

NOTE: Blocking can be added for extra strength.

Installing Post Sleeve Skirts and Post Sleeves

2. Slide post sleeve skirt over post and down to rest on decking surface. Slide post sleeve over post and position inside post sleeve skirt.

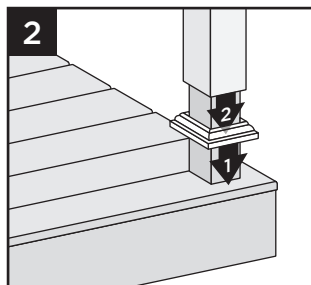

NOTE: Shims can be used to plumb post sleeves.

Option 2: With TrexExpress railing template:

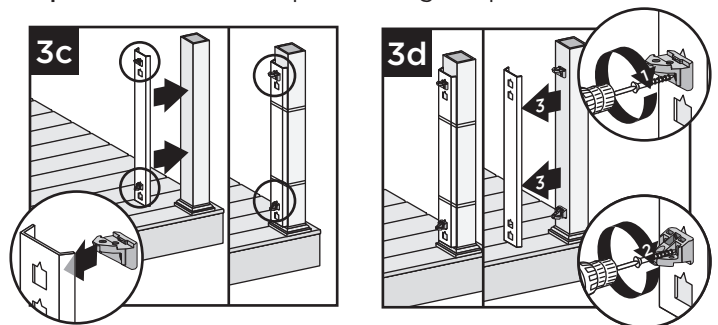

3c. Place RSBs in template. **Place top RSBs flat side UP, bottom RSBs flat side DOWN.** Secure template on post with tape or rubber band, with bottom of template resting on post skirt.

3d. Secure RSBs with 2" (51 mm) wood screws (provided in railing kit) and remove template.



HOW TO INSTALL STANDARD HORIZONTAL RAILING/CONTINUED

TREX TRANSCEND[®]

Cutting Railings and Baluster Spacers

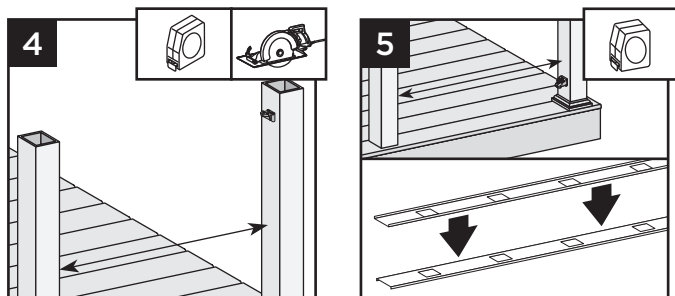

4. Measure between posts and cut rails to length.
5. Cut baluster spacers the same length as rails. Make sure the baluster spacer holes are equally spaced to ensure balusters will line up.

NOTES:

- » If using optional rail gaskets, subtract 1/16" (1.6 mm) from each end.
- » Attach baluster spacers to railing before cutting to allow for cleaner cut and less work.
- » When measuring, cut equal lengths from each side of railing and baluster spacer to ensure equal spacing of balusters per each railing section.
- » In some cases, the gasket can be attached before tightening railing to RSB.
- » If gaskets are tight, use a small flat head screwdriver to compress the tabs of the gasket if they are stuck outside the rail.

IMPORTANT NOTE REGARDING FOOT BLOCK INSTALLATION:

- » One foot block is **REQUIRED** for all railing spans. For commercial applications, spans over 6' will require two foot blocks.
- » Refer to detailed instructions (Trex Transcend[®] rail instructions) included with foot block prior to installation of railing section as these include other required steps for proper installation.

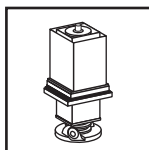

Attaching Foot Block to Bottom Rail

6. Invert the bottom rail. Center and drill a hole using a 3/16" drill bit. This will be location for foot block attachment to be installed last.

For spans over 6' in commercial applications drill two holes spaced evenly apart for two foot blocks.

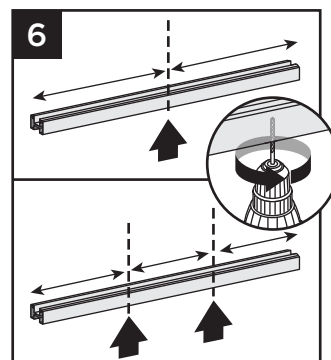

Attaching Bottom Rail (Universal Rail)

7. Lift bottom rail so RSBs are in the channel and attach with three self-drilling screws provided (use three outer holes; do not use hole in RSB that is closest to post).

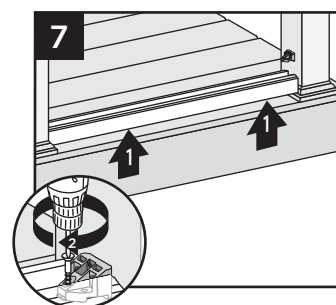

Attaching Top Rail - (Crown Rail)

8. Place crown rail on RSBs. Attach top rail to RSB with three self-drilling screws provided (use three outer holes; do not use hole in RSB that is closest to post).

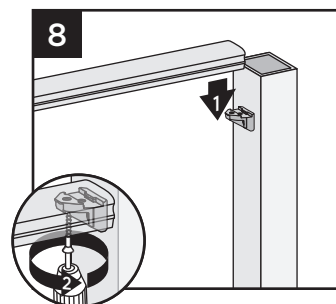

Placing Baluster Spacers

9. Snap baluster spacer into bottom rail. Place inverted baluster spacer on top of first baluster spacer. See page 62 if using aluminum round or square balusters for additional information.

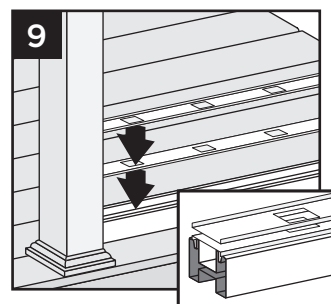

Attaching Balusters

10. Place baluster into both baluster spacers, ensuring that balusters are fully seated into the channel. Working at a slight angle, maneuver balusters into top rail.

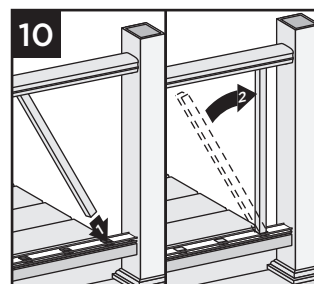

HOW TO INSTALL STANDARD HORIZONTAL RAILING/CONTINUED TREX TRANSCEND®

11. Slide baluster spacer up and snap into top rail. Place optional top rail gaskets on each end of rail.

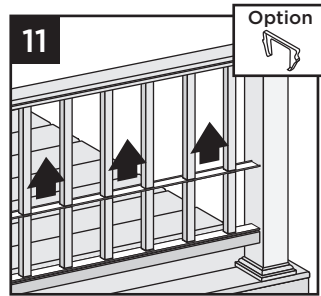

Attaching Post Caps and Installing Foot Blocks

12. Secure post caps with silicone or PVC adhesive. (apply adhesive on the inside self-centering/corner tabs) Attach foot block per foot block instructions.

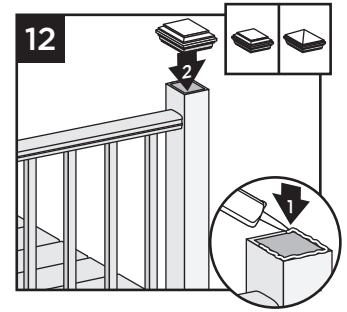

NOTE: Clean up any excess adhesive before it dries.

HOW TO INSTALL COCKTAIL HORIZONTAL RAILING TREX TRANSCEND

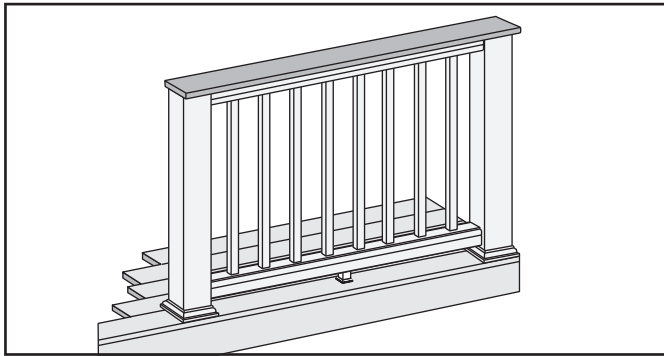

IMPORTANT NOTES:

- » **ONLY** use with 4" x 4" (102 mm x 102 mm) post and post sleeve. Cutting post and post sleeve **ONLY** applies to the Cocktail style railing.
- » *Enhance cannot be used as top board for cocktail rail.*

1. **Installing Pressure-Treated Posts**
See instructions on page 58.

Cutting Post and Post Sleeve

2. Mark and cut post and post sleeve measuring from deck surface:
- » 36-3/16" (919 mm) for 36" (914 mm) height.
 - » 42-3/16" (1072 mm) for 42" (1067 mm) height.

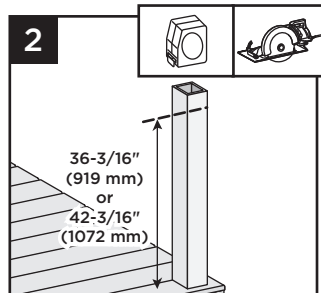

3. **Installing Post Sleeve Skirts and Post Sleeves**
See instructions on page 58.

4. **Installing Railing Support Brackets (RSBs)**
See instructions on page 58.

5. **Cutting Railings and Baluster Spacers**
See instructions on page 59.

6. **Attaching Foot Block to Bottom Rail**
See instructions on page 59.

7. **Attaching Bottom Rail (Universal Rail)**
See instructions on page 59.

Attaching Inverted Universal Rail as Top Rail

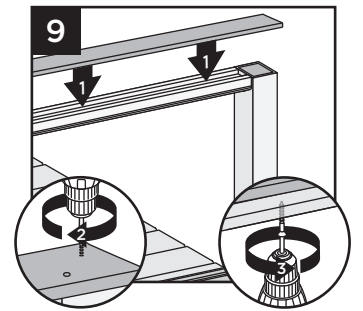
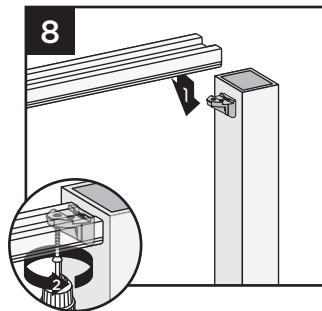

8. Place inverted universal rail onto RSBs. Attach universal rail to RSBs with three self-drilling screws provided (use three outer holes; do not use hole in RSB that is closest to post).
9. Place deck boards over universal rails (**DO NOT** use *Enhance deck boards for top rail*). Attach boards on each post with Trex-recommended composite screws (quantity of 2 per post as well as each board end). Secure boards to universal rails from underside of railing into bottom of decking board, with 1-5/8" (41 mm) pan-head screws (*not provided*) approximately every 16" (406 mm) on center.



HOW TO INSTALL COCKTAIL HORIZONTAL RAILING/CONTINUED TREX TRANSCEND®

10. Placing Baluster Spacers

See instructions on page 59.

11. Attaching Balusters

See instructions on page 59 for standard balusters or page 62 for aluminum balusters.

12. Slide baluster spacers up and snap into universal rails.

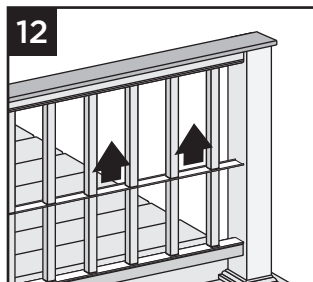

NOTE: If necessary, cut tips off rail gaskets prior to installation.

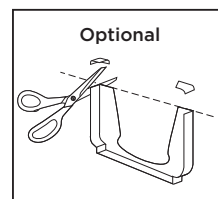

13. Use scarf cut for posts where two deck boards meet.

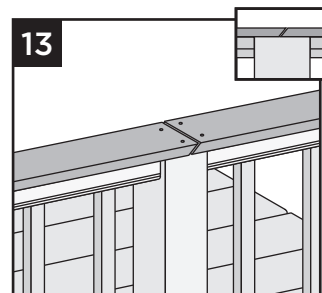

14. Installing Foot Block

Attach foot block per detailed instructions.

NOTES:

- » Leave 1/8" (3 mm) gap between deck boards.
- » Deck boards can overhang end of last post a maximum 1/2" (13 mm).

HOW TO INSTALL TRADITIONAL HORIZONTAL RAILING TREX TRANSCEND®

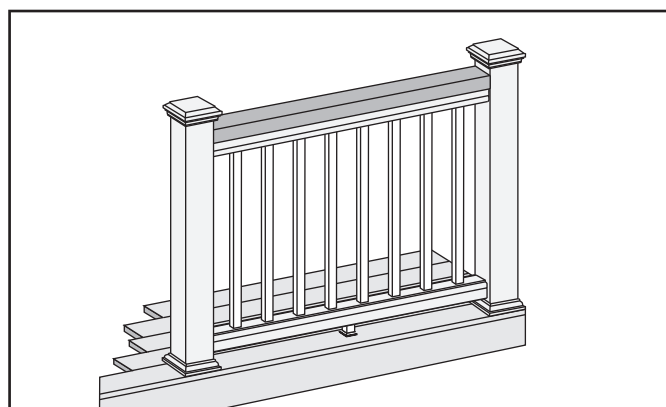

1. Installing Pressure-Treated Posts

See instructions on page 58.

2. Installing Post Sleeve Skirts and Post Sleeves

See instructions on page 58.

3. Installing Railing Support Brackets (RSBs)

See instructions on page 58.

4. Cutting Railings and Baluster Spacers

See instructions on page 59.

5. Attaching Foot Block to Bottom Rail

See instructions on page 59.

6. Attaching Bottom Rail (Universal Rail)

See instructions on page 59.

Attaching Inverted Universal Rail as Top Rail

7. Place inverted universal rail onto RSBs with balusters in channel. Attach universal rail with three self-drilling screws provided (use three outer holes; do not use hole in RSB that is closest to post).

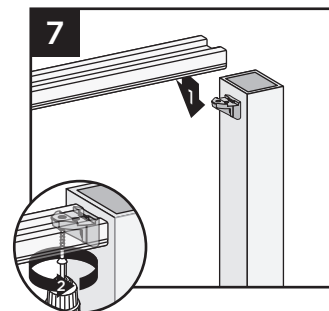

HOW TO INSTALL TRADITIONAL HORIZONTAL RAILING/CONTINUED TREX TRANSCEND®

8. Measure between posts and cut 2 x 4 to length.

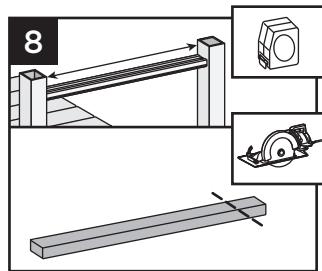

9. Place 2 x 4 on universal rail. Attach board to rail with 1-5/8" (41 mm) pan-head screws (not provided) approximately every 16" (406 mm) on center.

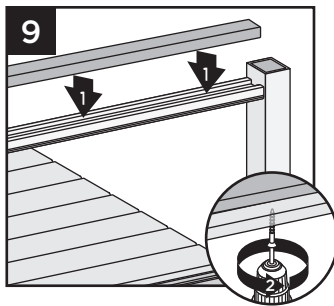

10. Pre-drill a pilot hole and toenail 2-1/2" (64 mm) composite decking screw (not provided) at each end of 2 x 4 into post on back side of rail (side not facing decking).

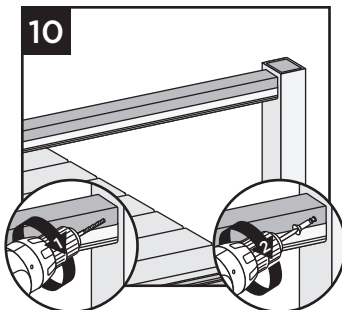

11. **Placing Baluster Spacers**

See instructions on page 59.

12. **Attaching Balusters**

See instructions (page 59) for standard balusters or instructions below for aluminum balusters.

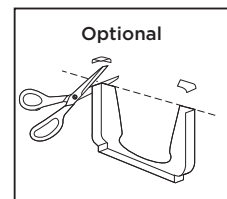
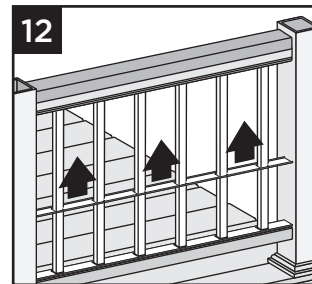

13. Slide baluster spacer up and snap into universal rail.

NOTE: If necessary, cut tips off rail gaskets prior to installation.

14. **Attaching Post Caps and Installing Foot Block**

Attach foot block per detailed instructions.

HOW TO INSTALL ROUND OR SQUARE ALUMINUM BALUSTERS TREX TRANSCEND®

1. **Installing Pressure-Treated Posts**

See instructions on page 58.

2. **Installing Post Sleeve Skirts and Post Sleeves**

See instructions on page 58.

3. **Installing Railing Support Brackets (RSBs)**

See instructions on page 58.

4. **Cutting Railings and Baluster Spacers**

See instructions on page 59.

5. **Attaching Foot Block to Bottom Rail**

See instructions on page 59.

6. **Attaching Bottom Rail (Universal Rail)**

See instructions on page 59.

Installing Lower Aluminum Baluster Adaptor Strip

7. After bottom rail is fully installed, place aluminum baluster adaptor strip into channel of bottom rail, ensuring that it's fully seated into the channel. When rail lengths are non-standard, the baluster adaptor strip will need to be cut 2-1/2" (64 mm) shorter than the rail to allow clearance for the RSBs on each end.

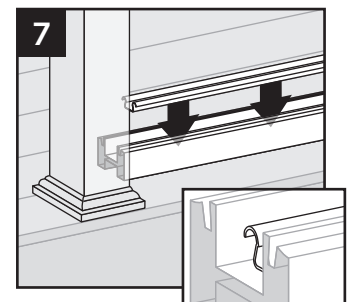

HOW TO INSTALL ROUND OR SQUARE ALUMINUM BALUSTERS/*CONTINUED* TREX TRANSCEND®

8. Attaching Top Rail

See specific instructions based on top rail of choice.

Installing Upper Aluminum Baluster Adaptor Strip, and Baluster Spacers

9. After top rail is fully installed, place aluminum baluster adaptor strip into channel of top rail, ensuring that it's fully seated into the channel. When rail lengths are non-standard, the adaptor strip will need to be cut 2 1/2" (64mm) shorter than the rail to allow clearance for the RBS's on each end.

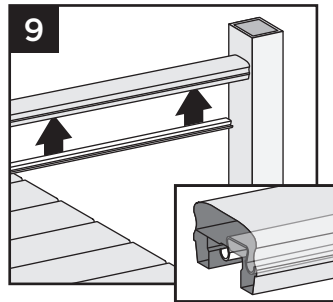

10. Snap baluster spacer into bottom rail. Place inverted baluster spacer on top of first baluster spacer.

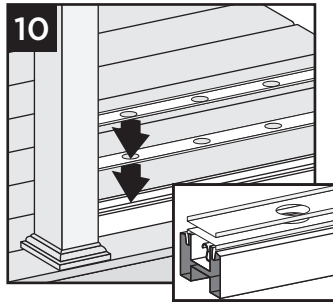

11. Attaching Balusters

Working at a slight angle, press baluster through both baluster spacers and into bottom aluminum baluster adaptor strip, ensuring balusters are tight. Once balusters are seated into aluminum baluster adaptor strip of bottom rail, maneuver baluster into upper rail aluminum baluster adaptor strip. Some force will be needed to press balusters into place and level them.

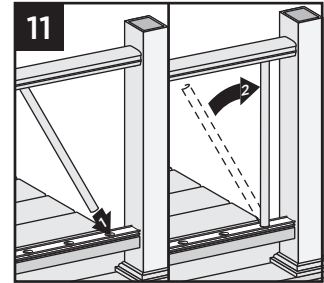

Tip: Ensure balusters are level prior to attempting to slide baluster spacer up. This will allow for the baluster spacer to move up freely and snap into upper rail. Use of a rubber mallet to gently tap balusters in level is recommended.

12. Slide baluster spacer up and snap into top rail. Place optional top rail gaskets on each end of rail.

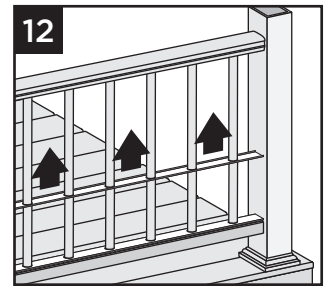

HOW TO INSTALL STANDARD HORIZONTAL GLASS PANEL RAILING TREX TRANSCEND

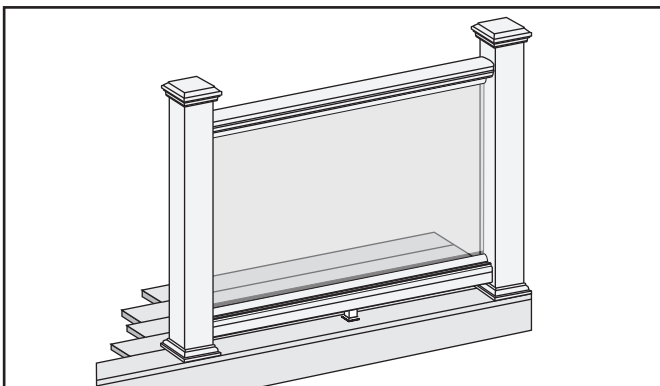

Notes: Read all instructions BEFORE installation.

- » You must purchase the 1/4" (6 mm) tempered glass panels. See dimensions below.
- » Glass panels **ONLY** for use with maximum 6' (1.83 m) on center post spacing.

HOW TO INSTALL STANDARD HORIZONTAL GLASS PANEL RAILING/CONTINUED TREX TRANSCEND®

TEMPERED GLASS PANEL DIMENSIONS

- » **36" (914 mm) high rail:**
1/4" x 30" x 63-1/2" max.
(6 mm x 762 mm x 1613 mm)
- » **42" (1067 mm) high rail:**
1/4" x 36" x 63-1/2" max.
(6 mm x 914 mm x 1613 mm)

1. **Installing Pressure-Treated Posts**
See instructions on page 58.
2. **Installing Post Sleeve Skirts and Post Sleeves**
See instructions on page 58.
3. **Installing Railing Support Brackets (RSBs)**
See instructions on page 58.
4. **Cutting Railings**
See instructions on page 59.
5. **Attaching Foot Block to Bottom Rail**
See instructions on page 59.
6. **Attaching Bottom Rail (Universal Rail)**
See instructions on page 59.

Attaching Weather-stripping and Positioning Panel

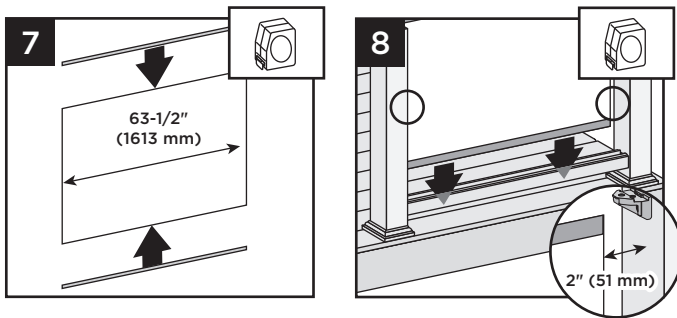

7. Push black edge trim onto top and bottom edges of glass panel. Be sure trim runs entire length of glass. Extra trim can be cut with razor blade or scissors.
8. Position panel with weather-stripping into lower rail channel. Center panel between posts with about 2" (51 mm) of air space on each side of panel.

Attaching Top (Crown) Rail

9. Place top rail over RSB brackets and glass panel. Attach top rail to RSB with three self-drilling screws provided (use three outer holes; do not use hole in RSB that is closest to post).

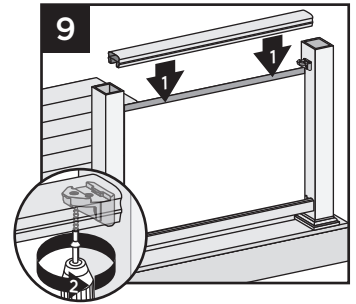

NOTE: Avoid hitting glass panel while using the drill.

Attaching Panel Support Molding (PSM)

10. Push PSM into bottom and top rails on both sides of glass to complete snap connection. Lower rail PSM edge rests on top of rail. Top rail PSM snaps flush into rail. When rail lengths are non-standard, the PSM will need to be cut the same length of the cut rails.

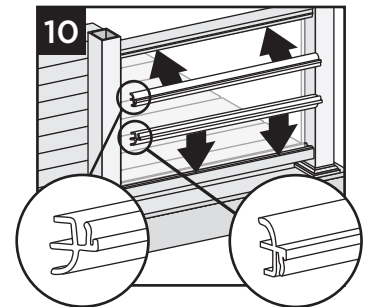

Hiding Brackets

11. Cut Transcend baluster spacer into four lengths equal to distance between the glass panel and posts. Cut slowly and one at a time to avoid chipping.

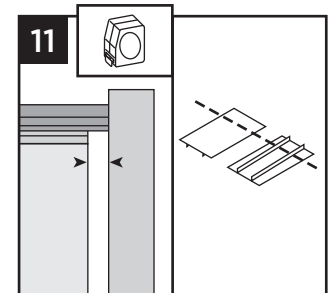

12. Snap spacer into bottom and top rail to hide brackets and create a seamless look.

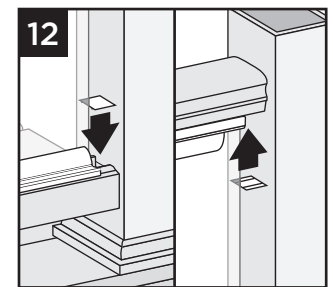

13. Attaching Post Caps and Installing Foot Blocks

See instructions on page 60 and provided detailed foot block instructions.

HOW TO INSTALL COCKTAIL HORIZONTAL GLASS PANEL RAILING TREX TRANSCEND®

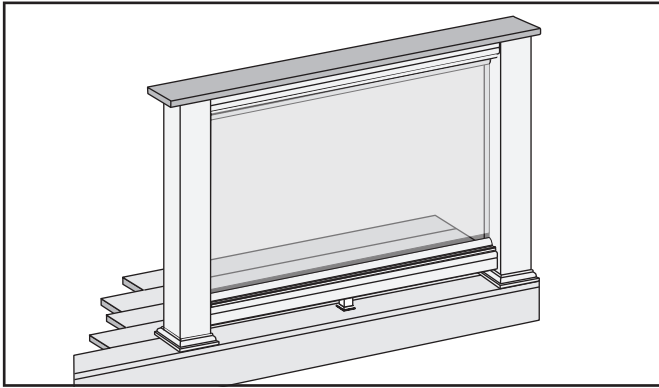

NOTES: Read all instructions BEFORE installation.

- » You must purchase the 1/4" (6 mm) tempered glass panels. See dimensions below.
- » Glass panels **ONLY** for use with maximum 6' (1.83 m) on center post spacing.
- » Trex post mounts cannot be used for this application.
- » **DO NOT** use Enhance deck board for top rail over universal rails.

TEMPERED GLASS PANEL DIMENSIONS

- » **36" (914 mm) high rail:**
1/4" x 30" x 63-1/2" max.
(6 mm x 762 mm x 1613 mm)
- » **42" (1067 mm) high rail:**
1/4" x 36" x 63-1/2" max.
(6 mm x 914 mm x 1613 mm)

1. Installing Pressure-Treated Posts

See instructions on page 58.

NOTE: If installing glass with cocktail rail design, rail posts and post sleeves must be cut.

2. Cutting Post and Post Sleeve

See instructions on page 58.

3. Installing Post Sleeve Skirts and Post Sleeves

See instructions on page 58.

4. Installing Railing Support Brackets (RSBs)

See instructions on page 58.

5. Cutting Railings

See instructions on page 59.

6. Attaching Foot Block to Bottom Rail

See instructions on page 59.

7. Attaching Bottom Rail (Universal Rail)

See instructions on page 59.

8-9. Attaching Weather-stripping and Positioning Glass Panel

See instructions on page 64.

Attaching Inverted Universal Rail as Top Rail

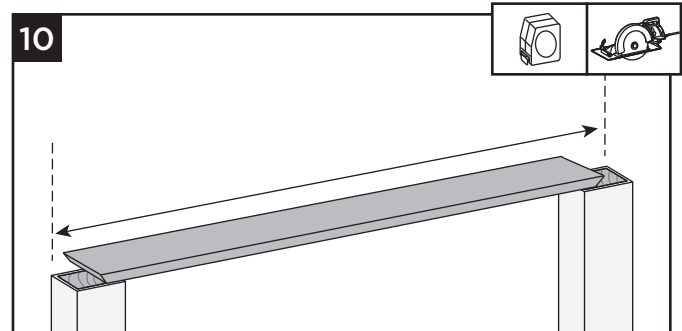

10. Cut deck boards to appropriate length of railing span, remembering to include extra space on each side of the deck board to allow for attachment to the post. Decking boards must cover 1/2 of the pressure-treated post to allow this to be fastened later. If you include extra decking material on each side, this can be cut off later if necessary.

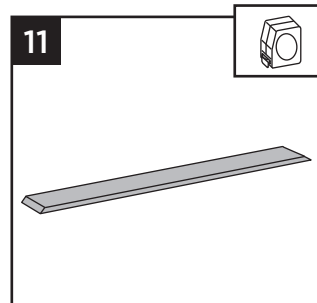

11. Place inverted deck board (place top side of deck board down) on clean, flat surface.

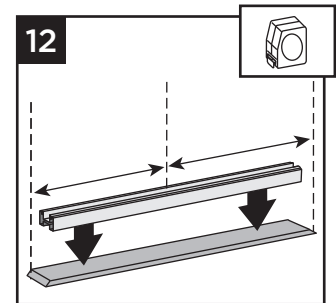

12. Place universal rail on the deck board. Orient this properly so when flipped over, the universal rail will accept the glass panel and panel support molding. Center in both directions to allow final attachment to post.

HOW TO INSTALL COCKTAIL HORIZONTAL GLASS PANEL RAILING TREX TRANSCEND®

13. Secure deck board to universal rail with 1 5/8" (41 mm) pan head screws (not provided), approximately every 16" (406 mm) on center. (DO NOT overtighten. Attach from underside of rail into bottom of decking board.)

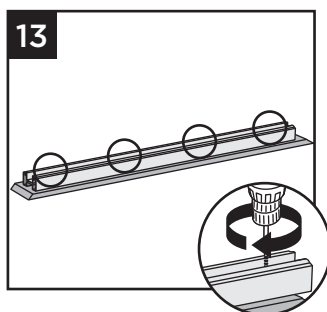

14. Place inverted universal rail with deck board attached over RSBs and glass panel. Attach universal rail to RSB's with three self-drilling screws provided (use three outer holes; do not use hole in RSB that is closest to post).

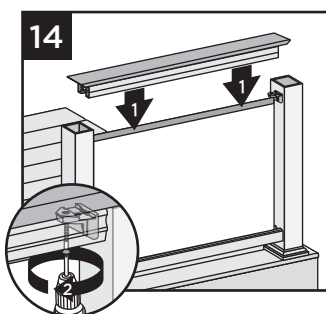

15. Attach deck board to post (ensure that screws are attached to wood post) with Trex recommended composite screws (quantity of 2 per each board end).

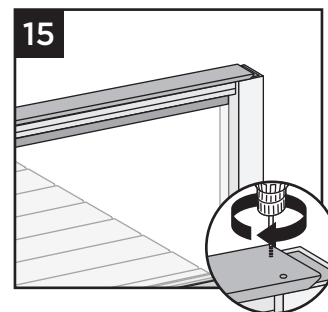

16. **Attaching Panel Support Moldings**
See instructions on page 64.

17-18. **Hiding Brackets**
See instructions on page 64.

19. **Installing Foot Block**
Attach foot block per provided detailed instructions.

HOW TO INSTALL TRADITIONAL HORIZONTAL GLASS PANEL RAILING TREX TRANSCEND

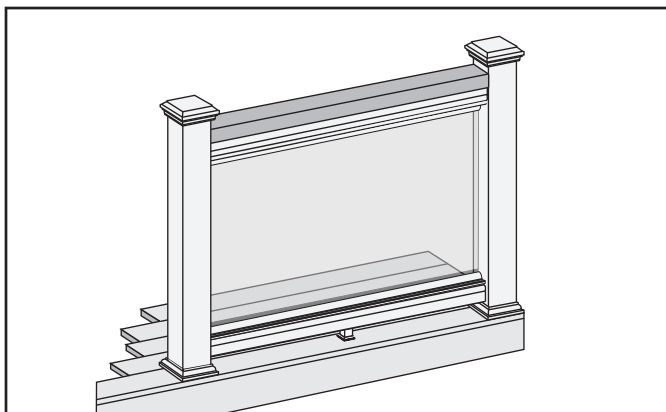

NOTES: Read all instructions BEFORE installation.

- » You must purchase the 1/4" (6 mm) tempered glass panels. See dimensions below.
- » Glass panels **ONLY** for use with maximum 6' (1.83 m) on center post spacing.

TEMPERED GLASS PANEL DIMENSIONS

- » **36" (914 mm) high rail:**
1/4" x 30" x 63-1/2" max.
(6 mm x 762 mm x 1613 mm)
- » **42" (1067 mm) high rail:**
1/4" x 36" x 63-1/2" max.
(6 mm x 914 mm x 1613 mm)

1. **Installing Pressure-Treated Posts**
See instructions on page 58.
2. **Installing Post Sleeve Skirts and Post Sleeves**
See instructions on page 58.
3. **Installing Railing Support Brackets (RSBs)**
See instructions on page 58.
4. **Cutting Railings**
See instructions on page 59.



HOW TO INSTALL TRADITIONAL HORIZONTAL GLASS PANEL RAILING/ CONTINUED TREX TRANSCEND®

5. Attaching Foot Block to Bottom Rail

See instructions on page 59.

6. Attaching Bottom Rail (Universal Rail)

See instructions on page 59.

7-8. Attaching Weather-stripping and Positioning Panel

See instructions on page 64.

Attaching Inverted Universal Rail as Top Rail

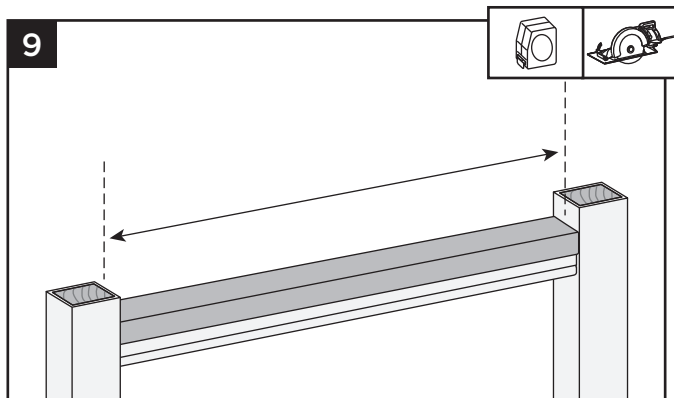

9. Measure between posts and cut 2 x 4 to length.

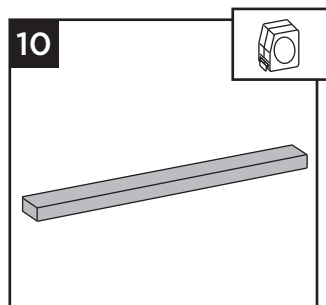

10. Place inverted 2 x 4 on clean, flat surface (place top side down).

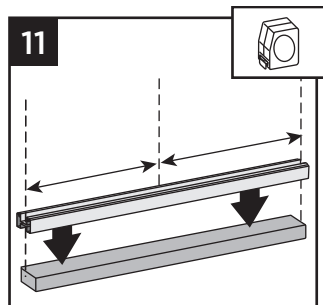

11. Place universal rail (remembering to orient this properly so that when flipped over, the universal rail will accept the glass panel and panel support molding), on the 2 x 4, centered.

12. Secure 2 x 4 to universal rail with 1-5/8" (41 mm) pan head screws (*not provided*) approximately every 16" (406 mm) on center (DO NOT overtighten. Attach from underside of rail into bottom of decking board.)

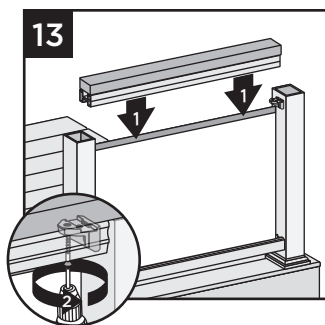
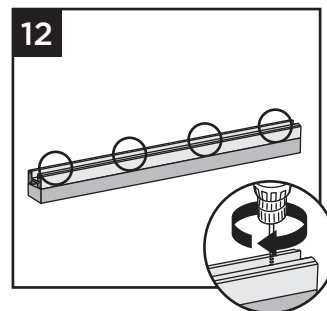

13. Place inverted universal rail with 2 x 4 attached over RSBs and glass panel. Attach universal rail to RSB's with three self-drilling screws provided (use three outer holes; do not use hole in RSB that is closest to post).

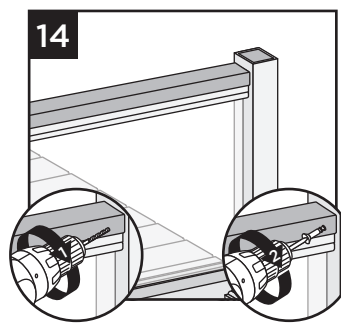

14. Pre-drill a pilot hole and toenail 2-1/2" (64 mm) composite deck screw (*not provided*) at each end of the 2 x 4 into post on back side (side not facing decking).

15. Attaching Panel Support Moldings

See instructions on page 64.

16-17. Hiding Brackets

See instructions on page 64.

18. Attaching Post Caps and Installing Foot Block

See instructions on page 64 and detailed foot block instructions.

HOW TO INSTALL ON-AN-ANGLE RAILING

TREX TRANSCEND® (CROWN AND UNIVERSAL RAILING)

NOTE: Trex railing brackets are designed to be installed up to a 45° angle.

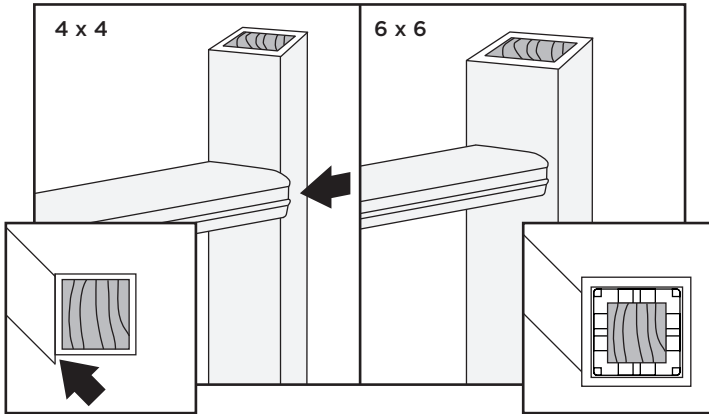

- » **Small angles** (1° - 30°). Both 4" x 4" (102 mm x 102 mm) or 6" x 6" (152 mm x 152 mm) post sleeves work well.
- » **Large angles** (31° - 45°). **Use only 6" x 6"** (152 mm x 152 mm) post sleeves when installing on flat side.
- » **45° angles** using 4" x 4" (102 mm x 102 mm) post sleeves **must** use Transcend Bird's Mouth brackets.
- » Using 6" x 6" (152 mm x 152 mm) post sleeves at 45° angles. Brackets are installed off-center and use 45° Transcend gaskets.
- » Railing gaskets are designed to fit at 0°, 22.5°, and 45° angles. Gaskets are labeled with appropriate angle dimension.

HOW TO INSTALL CROWN AND UNIVERSAL BIRD'S MOUTH HORIZONTAL RAILING

TREX TRANSCEND®

NOTES:

>>IMPORTANT - 6' and 8' rails cannot be installed at full on center post spans when using Bird's mouth applications. Rail posts must be spanned less than 6' or 8' OC.

- » Use with 4" x 4" (102 mm x 102 mm) post sleeve **ONLY**.
- » Gaskets are only designed for use with Transcend crown and universal railing.

Read all instructions **BEFORE** installation.

PARTS

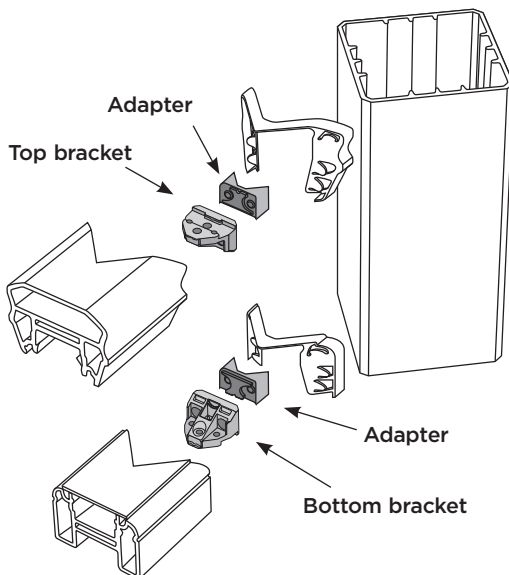

Mark Posts

1. Measure and mark 4" (102 mm) and 33-9/16" (852 mm) up from top of post skirt.

NOTE: Without skirt, add 1-1/2" (38 mm) to measurements.

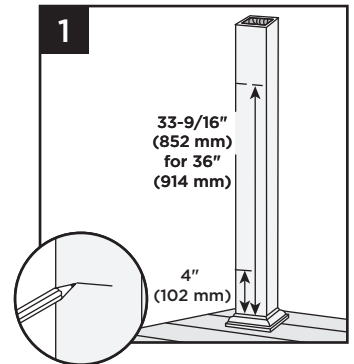

Attaching Adapters

Snap adapters into RSBs.

Pre-drill Bottom and Top RSBs

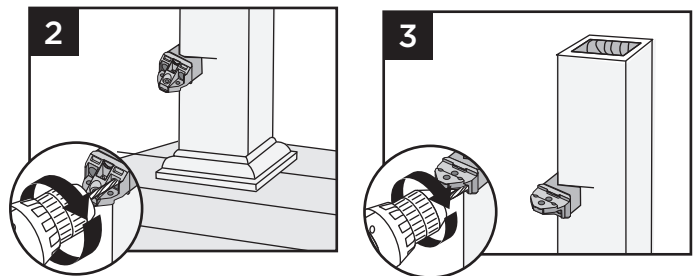

2. Position RSBs with adapter (flat side DOWN) for lower rail, mark and pre-drill screw holes with 1/8" (3 mm) drill bit on post.
3. Position RSBs with adapter (flat side UP) for top rail, mark and pre-drill screw holes with 1/8" (3 mm) drill bit on post.



HOW TO INSTALL CROWN AND UNIVERSAL BIRD'S MOUTH HORIZONTAL RAILING/CONTINUED TREX TRANSCEND™

Measuring and Cutting Rails

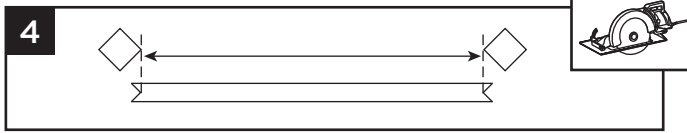

4. Measure from corner-to-corner between posts. Mark 45° cuts on rails with template on assembly tool. Center of “V’s” is the distance from corner-to-corner for posts.

NOTE: Subtract 1/16" (1.6 mm) from each end to accommodate rail gaskets.

Attaching Top and Bottom RSBs

5. Attach RSBs with adapters to posts with wood screws (provided).

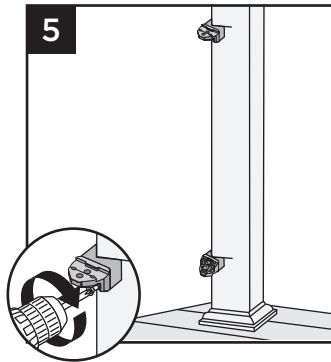

NOTES:

- » Drill at slight inward angle to drill holes on marks.
- » Lay cut lower rail into position on decking surface between the posts before attaching the lower RSB. There may be some difficulty attaching the lower rail if you fail to do this.

Installing Railings to RSB's

6. Attach with self-tapping screws (provided).

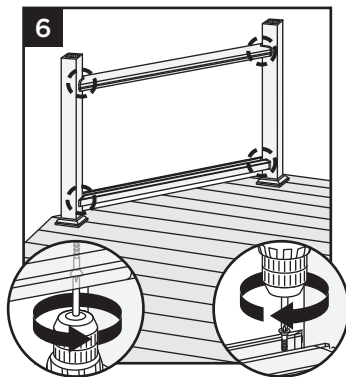

Using Miter Box Saw to Cut Rails

1. Place 2" x 4" (51 mm x 102 mm) on edge behind the rail to allow for complete cut.
2. Angle blade to 45°.
3. Set stop on saw so blade travels half the depth of rails. Several test cuts can be made on scrap material to accurately set the stop.
4. “V” cut both sides of the rail.

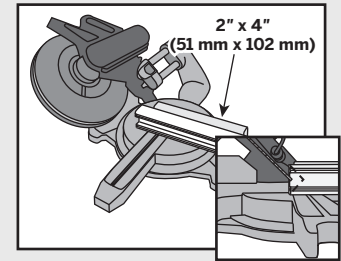

NOTE: Transcend's crown and universal rails will require different stop settings.

TREX TRANSCEND® HORIZONTAL STAIR RAILING

IMPORTANT NOTES:

- » TREX TRANSCEND RAILINGS ARE DESIGNED TO BE INSTALLED OVER THE DECKING FRAME OR ON INSIDE OF RIM JOIST. NOTCHING OF PRESSURE-TREATED POSTS OR POSTS INSTALLED ON OUTSIDE OF RIM JOIST IS NOT ALLOWED.
- » POST TO POST SPAN WILL BE LESS THAN 6' OR 8'. PRIOR TO INSTALLING POSTS CALCULATE POST TO POST SPAN USING A MAXIMUM RAIL LENGTH REQUIRED AND THE ANGLE (32°-37°) AT WHICH THE RAILS WILL BE INSTALLED. DO NOT INSTALL STAIR POSTS AT 6' OR 8' SPAN, AS STAIR RAILINGS WILL THEN BE TOO SHORT.

Care and Cleaning

Maintaining the appearance of your Trex Transcend railing is important. The occasional wash is recommended as over time your railing may show signs of weathering as a result of exposure to the elements. The frequency of cleaning will depend on the environment and exposure to various types of elements.

- » Clean railing using a standard cleaning vinegar or mild soap and water.
- » For more detailed cleaning recommendations please refer to the Trex Railing Care and Cleaning guide found on www.trex.com.

PARTS

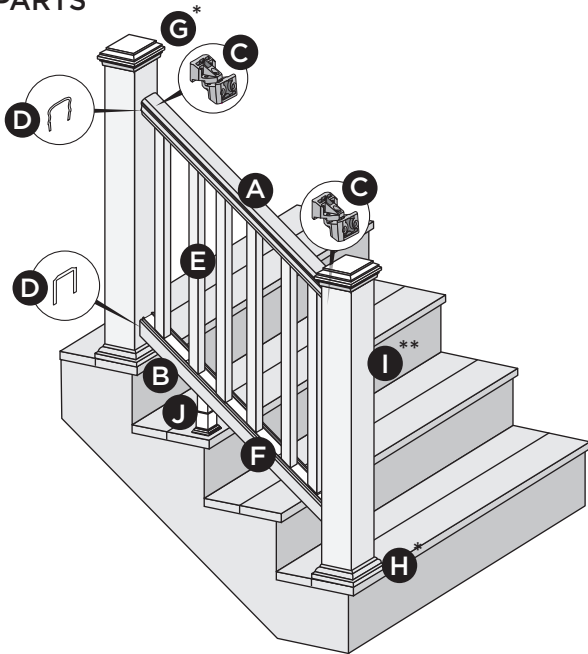

- A. Crown or Universal rail
- B. Universal rail
- C. Railing Support Brackets (RSB)
- D. Stair rail gaskets
- E. Balusters
- F. Stair baluster spacer
- G. Post sleeve cap*
- H. Post sleeve skirt*
- I. Post sleeve - 4" x 4" (102 mm x 102 mm) or 6" x 6" (152 mm x 152 mm)**
- J. Adjustable foot block (quantity of one is required for all railing span lengths)***

* Item not included in the Transcend railing kits.
 ** Both 4" x 4" (102 mm x 102 mm) and 6" x 6" (152 mm x 152 mm) post sleeves are designed to fit over 4x4 pressure-treated post.
 *** For commercial applications, spans over 6' will require two foot blocks. One will be included in kit, a second one will need to be purchased separately.

BALUSTER OPTIONS



NOTE: Pictorial representations shown may only show one style of railing, while others may also be used. Review detailed instructions to determine what railing styles and combinations can be used.

DETERMINING BALUSTERS NEEDED

Baluster Type	For 6' Stair Rail	For 8' Stair Rail
Standard (Stair Application)	11	15
Round/Square Aluminum (Stair Application)	12	16

NOTES:

- » Basic installation for balusters is the same for all options. When using round or square aluminum balusters, use correct baluster spacers.
- » If installing 42" (1067 mm) railing, use longer post sleeves and measure accordingly to ensure a proper cut. DO NOT CUT TO ACTUAL 42" LENGTH WITHOUT CONFIRMING WHAT STYLE OF RAILING YOU ARE INSTALLING.
- » Ensure pressure-treated posts are installed at proper heights so when post sleeves are installed, both the PT post and post sleeve are flush at top.
- » If using post mounts, refer to detailed instructions provided with post mounts for attaching these prior to installation of any railing type.

Screws Supplied with RSB

- C1. Wood screw for attachment of RSB to wood post/composite sleeve
- C2. Self-drilling screw for attachment of RSB to rail.

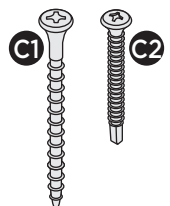

TREX TRANSCEND® STAIR RAILING CONFIGURATIONS

Note: See specific installation instructions for attachment of Trex Post Mounts or Trex Joist Mount Posts prior to installing any railing.

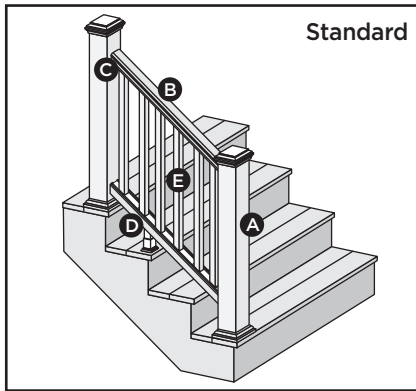

Cutting post sleeves is **NOT** required.

- A. Pressure-treated post/Trex post sleeve, Trex post mount/Trex post sleeve, or Joist Mount Post/Trex post sleeve (INSIDE MOUNT ONLY)
 - B. Crown rail
 - C. Universal bottom rail
 - D. Trex balusters (must also use appropriate stair baluster spacer)
- See page 72 for "How to Install Standard Stair Railing".

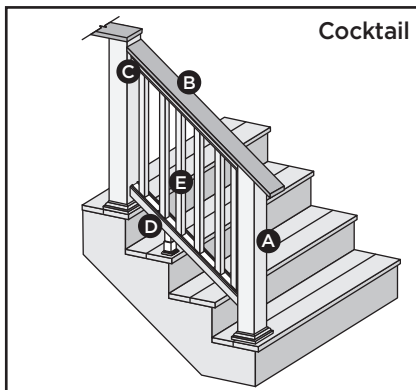

Post sleeves **WILL NEED TO BE CUT**.

- A. Pressure-treated post with Trex post sleeve
NOTE: » Only for use with 4" x 4" (102 mm x 102 mm) post sleeve.
» Trex post mounts cannot be used with Transcend cocktail design.
 - B. Deck board top rail (1 x 6 or 2 x 6). **NOTE:** Enhance cannot be used.
 - C. Universal top rail
 - D. Universal bottom rail
 - E. Trex balusters (must also use appropriate stair baluster spacer)
- See page 76 for "How to Install Cocktail Stair Railing".

**POST
SLEEVES
WILL
NEED TO
BE CUT**

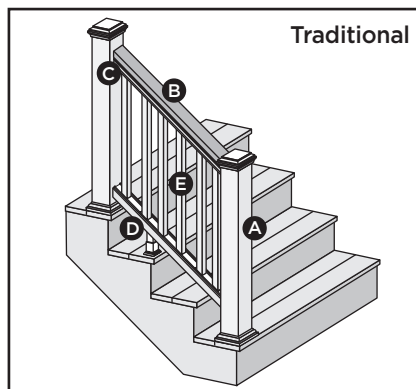

Cutting post sleeves is **NOT** required. Ensure both top and bottom post/post sleeves are tall enough to accommodate top rail and 2 x 4.

- A. Pressure-treated post/Trex post sleeve, Trex post mount/Trex post sleeve, or Joist mount post/Trex post sleeve (INSIDE MOUNT ONLY)
 - B. 2 x 4 top rail
 - C. Universal top rail
 - D. Universal bottom rail
 - E. Trex balusters (must also use appropriate stair baluster spacer)
- See page 78 for "How to Install Traditional Stair Railing".

NOTES:

- » If using Round or Square Aluminum Balusters, follow desired railing style instructions found above, substituting correct baluster spacer for type of baluster being used.

HOW TO INSTALL STANDARD STAIR RAILING

TREX TRANSCEND®

Installing Pressure-Treated Posts

- » PLEASE REFER TO LOCAL BUILDING CODE REQUIREMENTS PRIOR TO ATTACHING PRESSURE TREATED POSTS.
- » PRESSURE TREATED POSTS MUST BE INSTALLED ON INSIDE OF STAIR STRINGER AND AT NOSE OF STAIR TREAD.
- » POST TO POST SPAN WILL BE LESS THAN 6' OR 8'. PRIOR TO INSTALLING POSTS CALCULATE POST TO POST SPAN USING A MAXIMUM RAIL LENGTH REQUIRED AND THE ANGLE (32°-37°) AT WHICH THE RAILS WILL BE INSTALLED. DO NOT INSTALL STAIR POSTS AT 6' OR 8' SPAN, AS STAIR RAILINGS WILL THEN BE TOO SHORT.

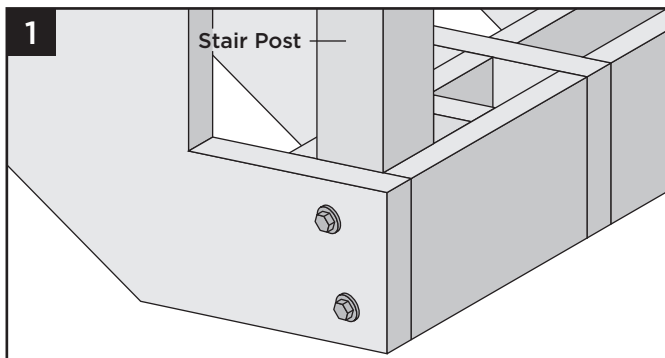
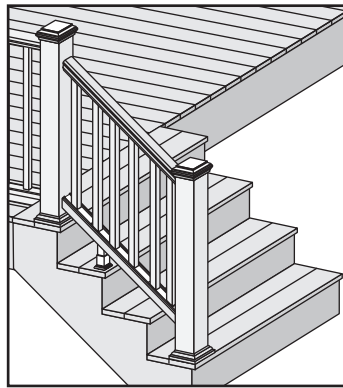

- » Attach posts using code approved hardware and also use added blocking.
- » Bolts can be countersunk flush with framing to allow for fascia attachment.
- » In most cases, a post and post sleeve longer than 39" (991 mm) will be needed on the lower section of stair rail to accommodate stair angle.

NOTE: Blocking can be added for extra strength.

Installing Post Sleeve Skirts and Post Sleeves

2. Slide post sleeve skirt over post and down to rest on decking surface. Slide post sleeve over post and position inside post sleeve skirt.

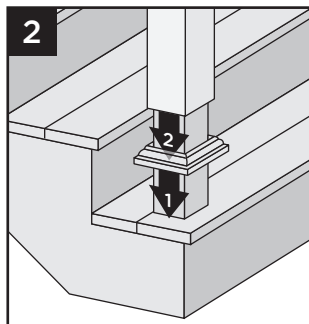

NOTE: Shims can be used to plumb post sleeves.

Measuring and Cutting Bottom Stair Rail

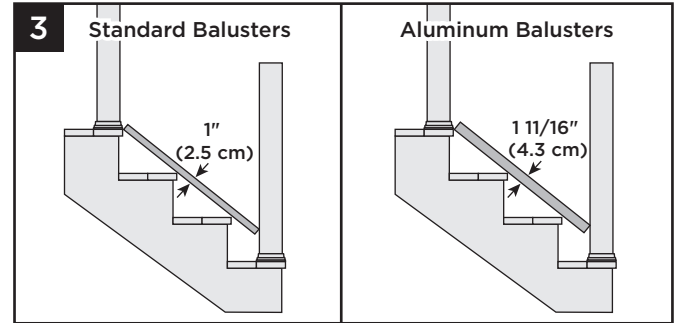

3. If using standard balusters, place a 1" (254 mm) deckboard on the nose of the stair tread. If using aluminum balusters, use a scrap piece of wood measuring at least 1-11/16" thick, and place on the nose of the stair tread.

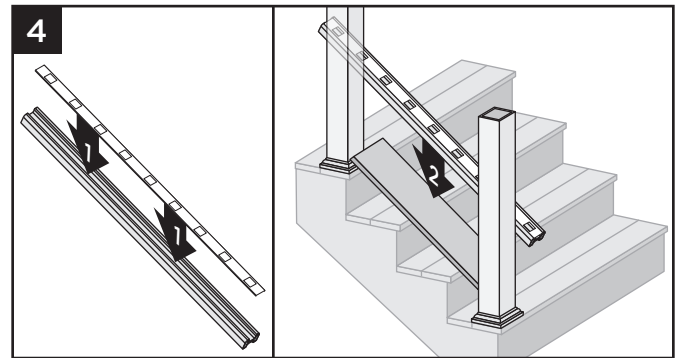

4. Snap baluster spacer into bottom stair rail and lay bottom stair rail on top of the deckboard.

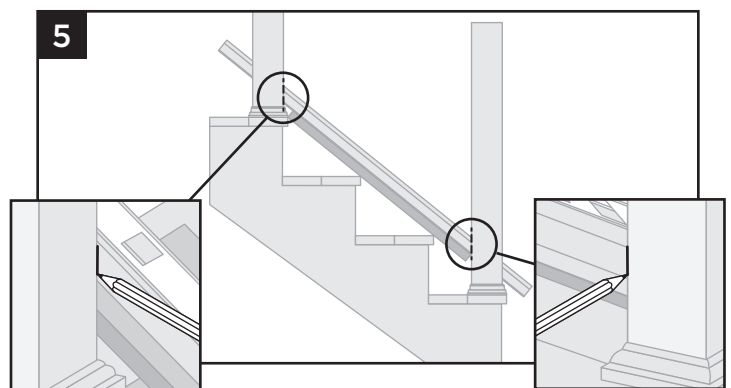

5. Use the lower and upper stair post to set the length of the bottom stair rail. Ensure that baluster spacer holes are spaced evenly between posts. Also allow for a minimum of 1-1/2" (292 mm) at each end of the stair rail for bracket placement and baluster clearance. Mark rail at post intersections.



HOW TO INSTALL STANDARD STAIR RAILING/CONTINUED

TREX TRANSCEND®

Marking Location for Foot Block to Bottom Rail

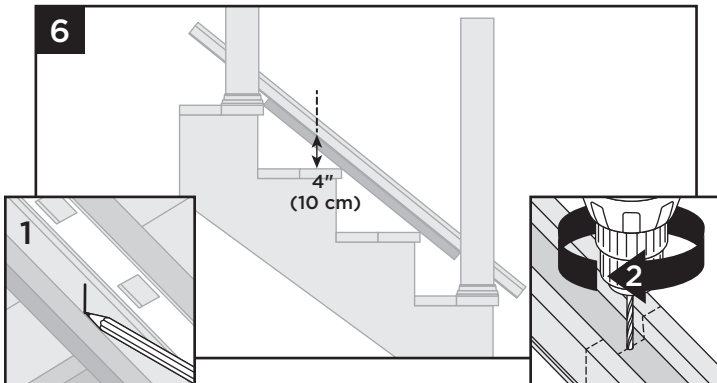

6. Mark approximate location for foot block, allowing a measurement of 4" maximum. Invert the bottom rail, and at marked location drill a hole using a 3/16" drill bit in the center of the channel. Foot block is to be installed at last step. For spans over 6' in commercial applications, mark and drill two locations spaced evenly apart for two foot blocks.

Cutting Bottom Stair Rail and Baluster Spacer

7. Keeping baluster spacer in rail, cut along marks.

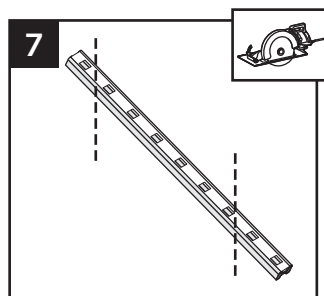

NOTES:

- » If using rail gaskets, subtract 1/16" from each end and cut.
- » KEEP BALUSTER SPACER IN RAIL WHEN CUTTING. CUT VERY CAREFULLY TO NOT BREAK BALUSTER SPACER.

Attaching RSB's for Bottom Stair Rail

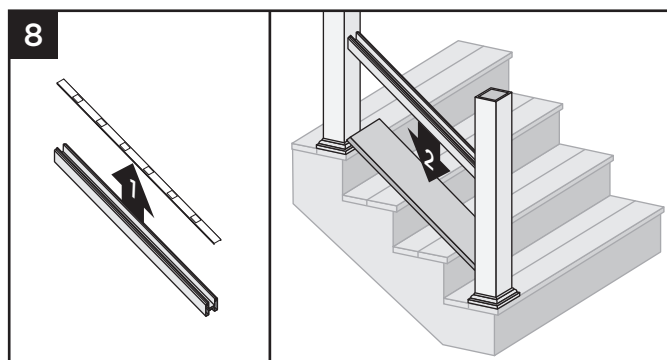

8. Remove baluster spacer from bottom rail and place rail in between posts, keeping rail on deckboard.

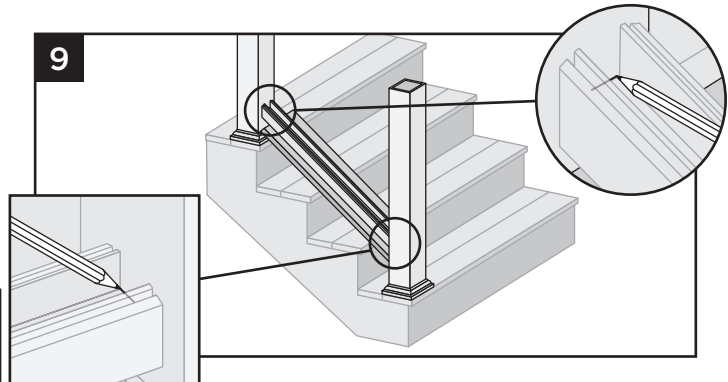

9. Mark both posts on inside channel of the bottom stair rail. Remove bottom stair rail.

10. For **UPPER** post - install **RSB FLAT SIDE DOWN, ABOVE MARKED LINE**, using two wood screws provided. Take second RSB, turn upside down and interlock into first RSB.

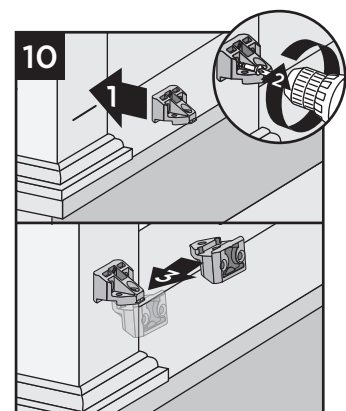

11. For **LOWER** post - install **RSB FLAT SIDE UP, ABOVE MARKED LINE**, using two wood screws provided. Take second RSB, turn upside down and interlock into first RSB.

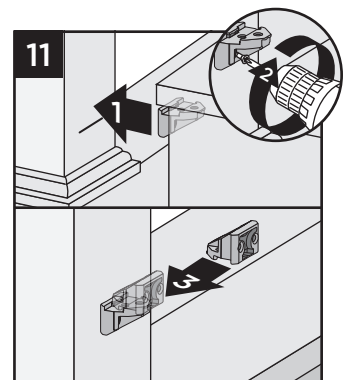

Attaching Bottom (Universal) Stair Rail

12. Lift bottom stair rail so RSB's are in the channel and attach with 3 self-drilling screws provided. Use the three outer holes in RSB to attach screws.

Tip: Deckboard can be placed underneath bottom stair rail to help hold rail firmly in place while attaching.

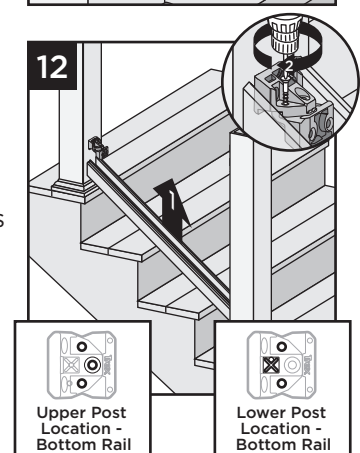

HOW TO INSTALL STANDARD STAIR RAILING/CONTINUED

TREX TRANSCEND®

IMPORTANT NOTE IF INSTALLING ALUMINUM BALUSTERS: If necessary cut aluminum baluster adaptor strip at appropriate length to ensure this can be fully seated into the bottom stair rail without interfering with the RSBs.

13. Snap bottom baluster spacer into bottom stair rail.

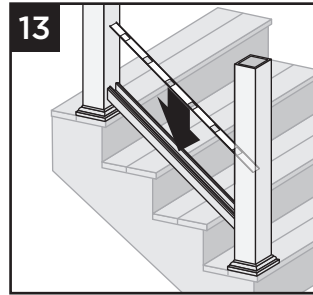

14. Place two balusters into bottom stair rail at each end closest to the post, and ensure these balusters are parallel to posts.

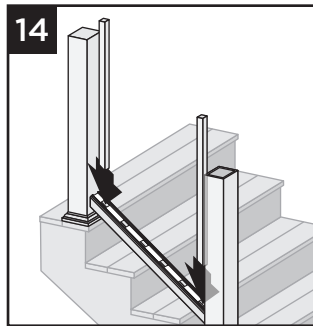

Tip: Use clamps to help hold balusters in place.

Measuring and Cutting Top Stair Rail and Baluster Spacer

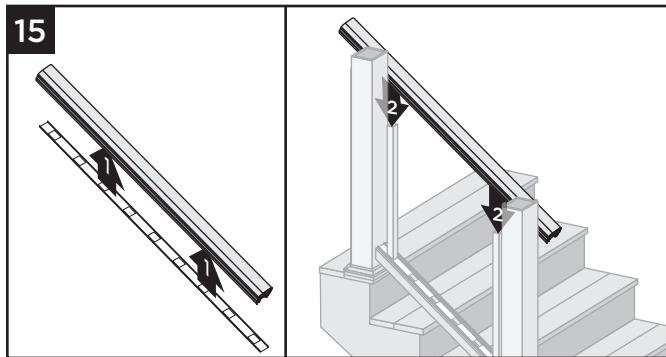

15. Snap baluster spacer into top stair rail. Position top stair rail onto balusters, ensuring balusters are fully seated in rail (position to side of post), and **ENSURE** that balusters are spaced evenly **AND** parallel with post. Also allow for a minimum of 1-1/2" (292 mm) at each end of the stair rail for bracket placement and baluster clearance.

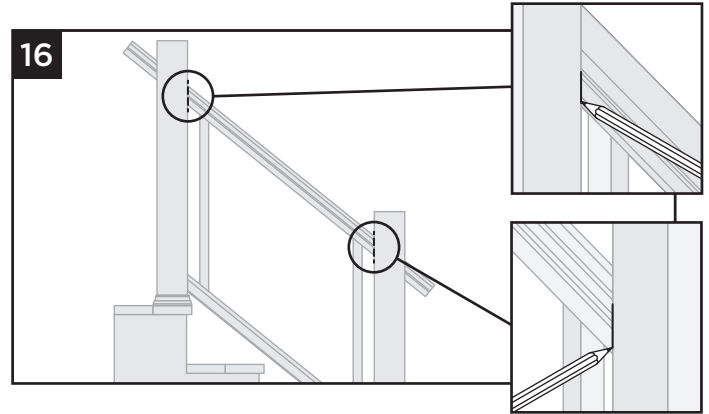

16. Mark rail at post intersection.

17. Remove top rail, keeping baluster spacer in rail, and cut along marks.

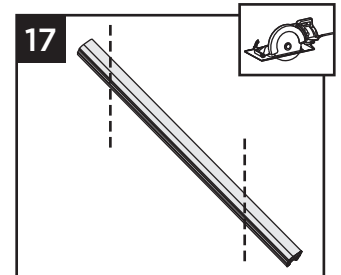

NOTES:

- » If using rail gaskets, subtract 1/16" from each end and cut.
- » **KEEP BALUSTER SPACER IN RAIL WHEN CUTTING. CUT VERY CAREFULLY IN ORDER TO NOT BREAK BALUSTER SPACER.**

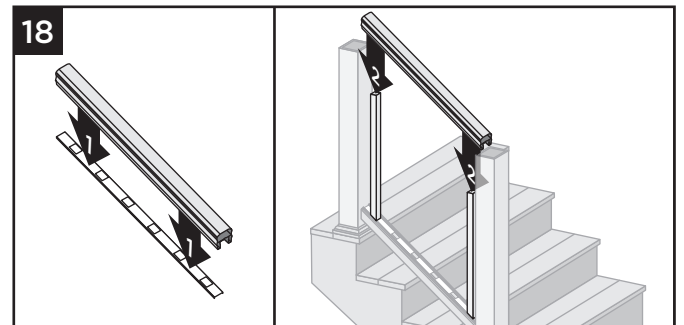

18. Remove baluster spacer from top stair rail and place rail in between posts on top of balusters, **ENSURING** that balusters remain parallel to post.

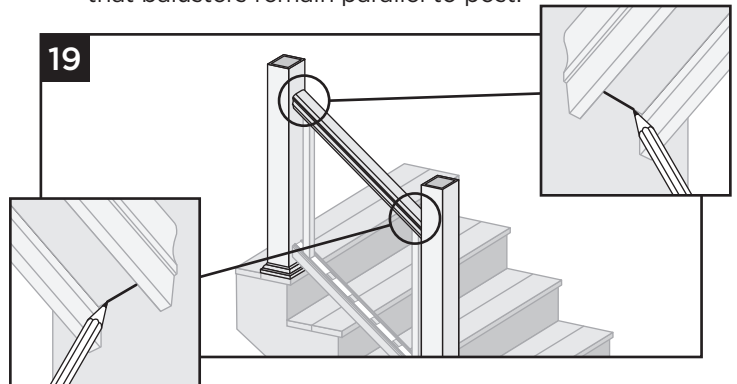

19. Mark both posts on inside channel of the top stair rail. Remove top stair rail.



NOTE: Construction methods are always improving. Please refer to www.trex.com for the most up-to-date installation requirements.

HOW TO INSTALL STANDARD STAIR RAILING/CONTINUED

TREX TRANSCEND®

20. For **UPPER** post - install **RSB FLAT SIDE DOWN BELOW MARKED LINE**, using two wood screws provided. Take second RSB, turn upside down and interlock into first RSB.

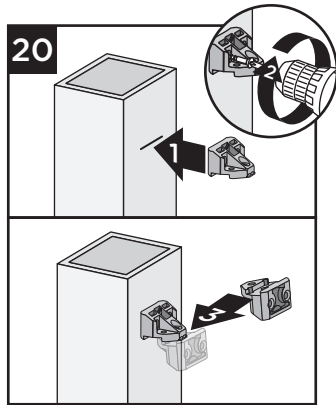

21. For **LOWER** post - install **RSB FLAT SIDE UP BELOW MARKED LINE**, using two wood screws provided. Take second RSB, turn upside down and interlock into first RSB.

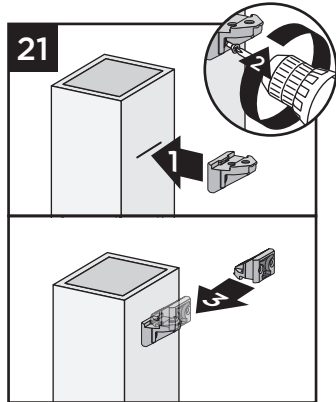

Attaching Top Stair Rail

23. Place top stair rail on RSB's (ensuring balusters are also in channel of rail). Attach with 3 self-drilling screws provided. Use the three outer holes in RSB to attach screws.

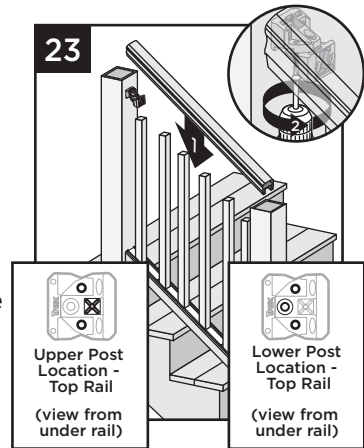

24. Slide baluster spacer up and snap into top rail.

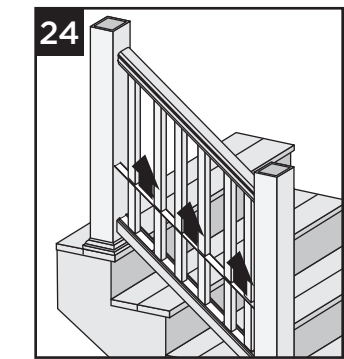

Installing Inverted Top Baluster Spacer and Placing Balusters

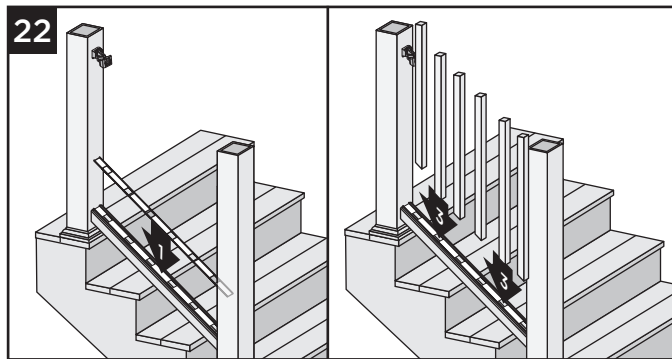

22. Place inverted top baluster spacer on bottom rail rail/baluster spacer, ensuring that baluster holes line up. Install balusters into bottom stair rail.

Installing Optional Gaskets

25. Stair rail gaskets are designed to fit at slopes of 32° to 37°. Gaskets are labeled in order to ensure correct location.

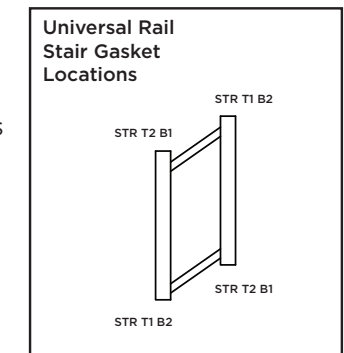

Attaching Post Caps and Installing Foot Block

26. Secure post caps with silicone or PVC adhesive (apply adhesive on the inside self-centering corner tabs). Attach foot block per foot block instructions.

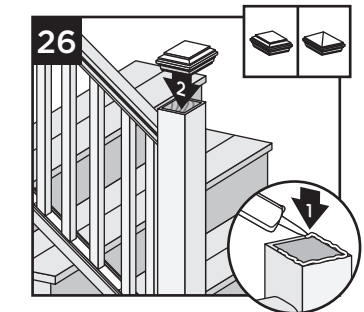

NOTE: Clean-up any excess adhesive before it dries.

HOW TO INSTALL COCKTAIL STAIR RAILING

TREX TRANSCEND®

IMPORTANT NOTES:

- » Only for use with pressure-treated 4 x 4 post (3.5" nominal square) and 4" x 4" (102 mm x 102 mm) post sleeve. Trex post mounts or joist mount posts cannot be used with Trex Transcend stair railing. Cutting post and post sleeve only applies to Cocktail style railing.

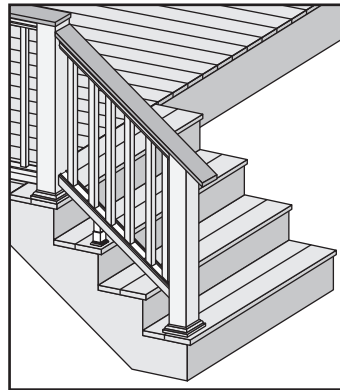

- » **DO NOT CUT POST/POST SLEEVES UNTIL TOP RAIL IS FULLY INSTALLED. THE DECK BOARD USED IN TRANSCEND STAIR COCKTAIL RAILING WILL NEED TO TERMINATE AT THE TOP OF THE POST AS SHOWN ABOVE. THE DECK BOARD WILL HAVE TO BE INSTALLED INTO THE SIDE OF THE POST IN THESE AREAS USING 2 APPROPRIATE COMPOSITE DECKING SCREWS - PRE-DRILLING IS RECOMMENDED.**

Installing Pressure-treated Posts, Post Sleeves, and Skirts

1. See instructions on page 72. See notes on page 72 regarding not cutting post/post sleeve.

Measuring and Cutting Bottom Stair Rail

2. See instructions on page 72.

Marking Location for Foot Block on Bottom Rail

3. See instructions on page 73.

Attaching RSB's for Bottom Stair Rail

4. See instructions on page 73.

Attaching Bottom (Universal) Stair Rail

5. See instructions on page 73.

IMPORTANT NOTE: REMEMBER TO INVERT UNIVERSAL TOP RAIL BEFORE MARKING AND CUTTING

Measuring and cutting Top Stair Rail

6. See instructions on page 74.

Measuring and Cutting Deck Board

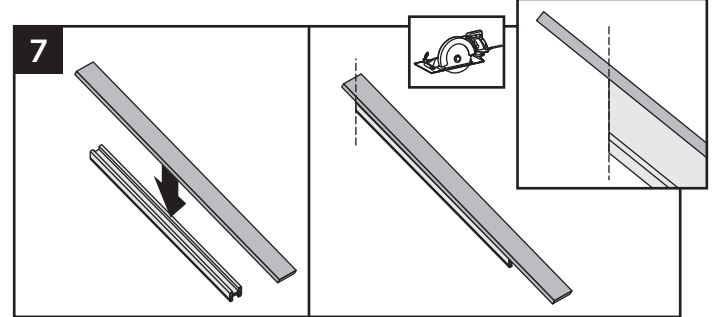

7. Using the cut top rail as template, cut deck board at upper post location at same angle as the top rail. Leave a generous amount of deck board material at lower post location as this will allow for overhang and can be cut later.

Attaching RSB's for Top Stair Rail

8. See instructions on page 75.

Installing Inverted Top Baluster Spacer and Placing balusters

9. See instructions on page 75.
DO NOT SLIDE TOP BALUSTER SPACER INTO PLACE YET.

Attaching Top Stair Rail

10. See instructions on page 75.

Cutting Lower Post/Post Sleeve

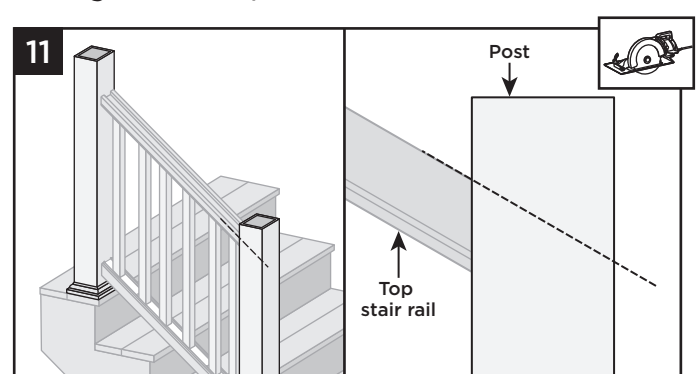

11. Cut post and post sleeves to proper angle so cut is flush with the top rail. Be careful to not cut top rail.



HOW TO INSTALL COCKTAIL STAIR RAILING CONTINUED

TREX TRANSCEND®

Attaching Deck Board to Top Stair Rail and Securing Balusters

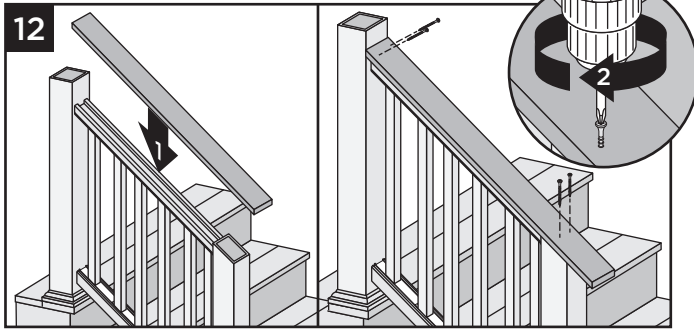

12. Place deck board on top rail and attach board to posts using two Trex recommended composite decking screws (use two screws per each post).

NOTE: At upper post location pre-drilling is recommended and install screws perpendicular to the post.

13. Secure board to top (universal) rail from underside of rail into bottom of deck board with 1-5/8" (41 mm) pan-head screws (*not provided*) approximately every 16".

NOTE: balusters can be shifted out of the way if necessary.

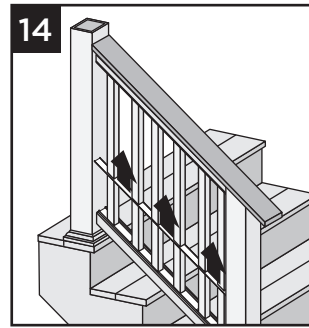
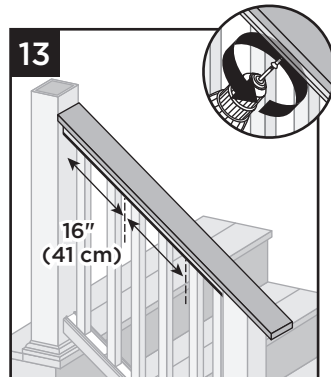

14. Slide baluster spacer up and snap into top rail.

Installing Optional Gaskets

15. See instructions on page 75.

NOTE: Top gaskets may have to be trimmed to fit properly.

Installing Foot Block

16. See instructions on page 75.

HOW TO INSTALL TRADITIONAL STAIR RAILING

TREX TRANSCEND®

Installing Pressure-treated Posts, Post Sleeves, and Skirts

1. See instructions on page 72.

Measuring and Cutting Bottom Stair Rail

2. See instructions on page 72.

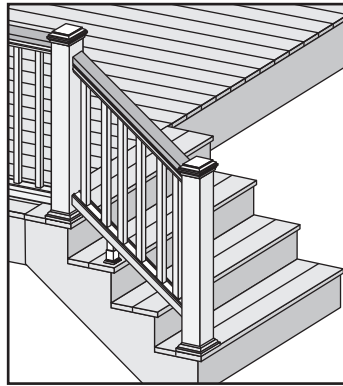

Marking Location for Foot Block on Bottom Rail

3. See instructions on page 73.

Attaching RSB's for Bottom Stair Rail

4. See instructions on page 73.

Attaching Bottom (Universal) Stair Rail

5. See instructions on page 73.

IMPORTANT NOTE: REMEMBER TO INVERT UNIVERSAL TOP RAIL BEFORE MARKING AND CUTTING

Measuring and cutting Top Stair Rail

6. See instructions on page 74.

Measuring and Cutting 2x4

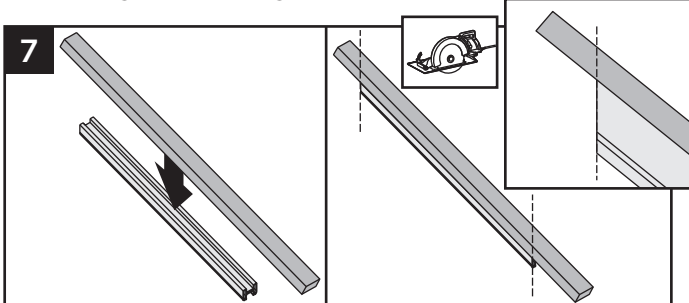

7. Using the cut top rail as template, cut 2x4 at same angle and length of the top rail.

Attaching RSB's for Top Stair Rail

8. See instructions on page 75.

Installing Inverted Top Baluster Spacer and Placing Balusters

9. See instructions on page 75.

DO NOT SLIDE TOP BALUSTER INTO PLACE YET.

Attaching Top Stair Rail

10. See instructions on page 75.

Attaching 2x4 to Top Stair Rail and Securing Balusters

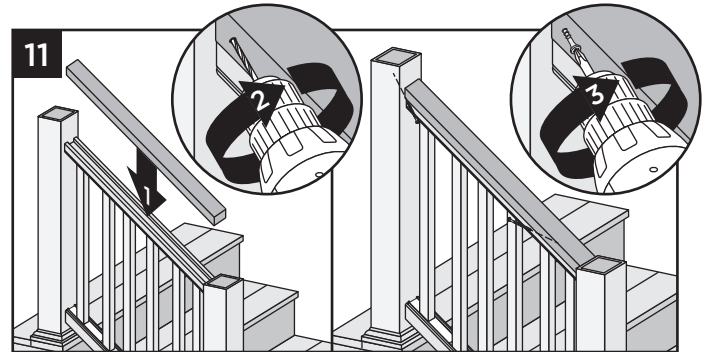

11. Pre-drill a pilot hole and toenail 2-1/2" (6.4 cm) composite deck screw at each end of 2 x 4 into post on back side of stair rail (side not facing decking).

12. Secure 2x4 to top(universal) rail from underside of rail into bottom of 2x4 with 1-5/8" pan-head screws (not provided) approximately every 16".

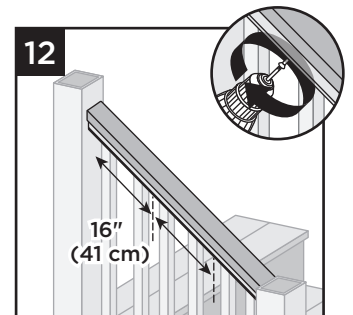

NOTE: Balusters can be shifted out of the way if necessary.

13. Slide baluster spacer up and snap into top rail.

Installing Optional Gaskets

14. See instructions on page 75.

NOTE: top gaskets may have to be trimmed to fit properly.

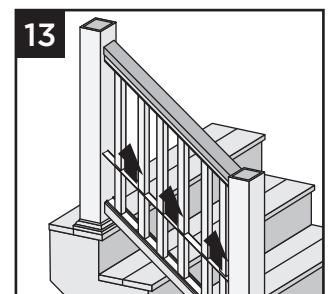

Attaching Post Caps and Installing Foot Block

15. See instructions on page 75.

TREX SIGNATURE® RAILING

NOTES:

- » ALL TREX SIGNATURE SPANS OVER 6' WILL REQUIRE THE USE OF A FOOT BLOCK. THUS THESE RAILING SPANS MUST BE INSTALLED OVER THE DECKING FRAME OR ON INSIDE OF RIM JOIST.
- » TREX SIGNATURE POSTS CANNOT BE USED WITH TREX SIGNATURE TRADITIONAL OR TREX SIGNATURE COCKTAIL DESIGNS, ONLY PRESSURE-TREATED POSTS/POST SLEEVES CAN BE USED. REFER TO DETAILED INSTRUCTIONS FOR MORE INFORMATION.
- » TREX SIGNATURE RAILINGS ARE DESIGNED TO BE ATTACHED WITH POSTS INSTALLED AT A CLEAR SPAN OF 6' (1.83 M) OR 8' (2.44 M).
- » IF INSTALLING AT EXACT SPAN LENGTHS OF 6' (1.83 M) OR 8' (2.44 M), AND USING POST-TO-POST CONFIGURATION, THE BOTTOM RAIL WILL NOT NEED TO BE CUT, BUT THE TOP RAIL WILL NEED TO BE MEASURED (MAKING SURE BALUSTERS LINE UP VERTICALLY) AND CUT.
- » IF INSTALLING AT EXACT SPAN LENGTHS OF 6' (1.83 M) OR 8' (2.44 M), AND USING CROSSOVER POST CONFIGURATION (SPANS FROM ONE CROSSOVER POST TO ANOTHER CROSSOVER POST), BOTH THE BOTTOM RAIL AND TOP RAIL WILL NOT NEED TO BE CUT.
- » IN ADDITION, AT ALL FINAL END POST CONFIGURATIONS, TOP RAIL WILL NEED TO BE MEASURED (MAKING SURE BALUSTERS LINE UP VERTICALLY) AND CUT.
- » SEE INFORMATION WITHIN DETAILED INSTRUCTIONS FOR MORE INFORMATION.
- » SEE PAGE 51-52 FOR SKU NUMBERS.

PARTS

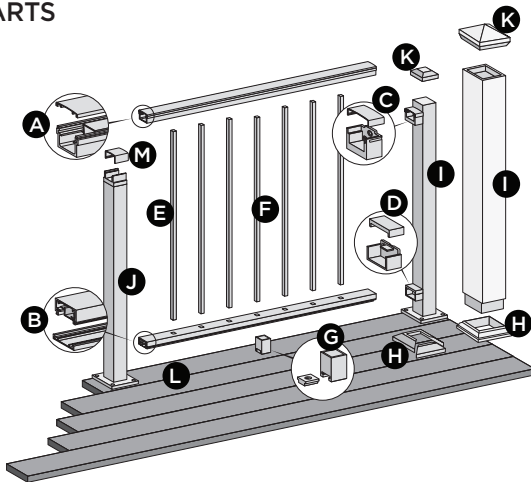

BALUSTER OPTIONS

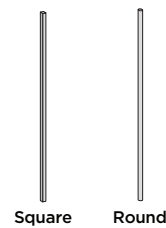

DETERMINING BALUSTERS NEEDED

Baluster Type	Per 6' Section	Per 8' Section	Per 6' Stair Section	Per 8' Stair Section
Square	15	20	13	17
Round	15	20	13	17

NOTE: THIS IS AN OVERVIEW OF ALL RAILING COMPONENTS FOR TREX SIGNATURE HORIZONTAL APPLICATIONS - REFER TO DETAILED INSTRUCTIONS FOR SPECIFIC RAILING CONFIGURATIONS.

- A. Trex Signature top rail and crowned cover
 - 6' (actual length 73.5" [186.7 cm])
 - 8' (actual length 97.5" [247.7 cm])
- B. Trex Signature bottom rail and flat cover
 - 6' (actual length 71.5" [181.6 cm])
 - 8' (actual length 95.5" [242.6 cm])
- C. Trex Signature upper rail bracket and cover
- D. Trex Signature lower rail bracket and cover
- E. Trex Signature balusters (square or round)
- F. Trex Signature center baluster (square or round)
- G. Trex Signature foot block**
- H. Trex Signature post skirt or post sleeve skirt*
- I. Trex Signature post*
 - 36" (actual length 37" [94.0 cm])
 - 42" (actual length 43" [109.2 cm])
 - or Trex post sleeve***
 - 36" (actual length 40" [102 cm])
 - 42" (actual length 46" [117 cm])

- J. Trex Signature crossover post*
 - 36" (actual length 34.5" [87.6 cm])
 - 42" (actual length 40.5" [102.9 cm])
- K. Trex Signature post cap or post sleeve cap*
- L. Trex decking
- M. Crossover bracket cover (supplied with crossover post)

* Item not included in Trex Signature Railing kits.

** Required ONLY for All Clear Span Applications over 6' (1.83 m) when smaller fixed baluster is fully centered, or unsupported spans greater than 5' (1.52 m) (example: 8' (2.44 m) span cut into one 5' (1.52 m) span and one 3' (0.91 m) span would require foot block under 5' (1.52 m) span since smaller fixed baluster is no longer centered). Included with 8' (2.44 m) railing kits.

*** Both 4" x 4" (10.2 cm x 10.2 cm) and 6" x 6" (15.2 cm x 15.2 cm) post sleeves are designed to fit over 4" x 4" pressure-treated post.

NOTE: If installing 42" (106.7 cm) railing, and using pressure-treated posts with Trex post sleeves, ensure that a longer pressure-treated post is used along with longer post sleeve, both cut to a height of 46" (116.8 cm) from decking surface.

NOTE: MUST USE TREX DECK MOUNT POST HARDWARE AND METAL PLATE WHEN ATTACHING TREX SIGNATURE POSTS.

INSTALLING TREX SIGNATURE® POSTS AND/OR CROSSOVER POSTS ON WOOD OR CONCRETE

IMPORTANT NOTES:

- » EACH POST MUST BE ATTACHED AS SHOWN TO ENSURE A CODE-COMPLIANT AND SAFE INSTALLATION.
- » TREX SIGNATURE POSTS CANNOT BE USED WITH TREX SIGNATURE TRADITIONAL OR TREX SIGNATURE COCKTAIL DESIGNS, ONLY PRESSURE-TREATED POST/POST SLEEVES CAN BE USED. REFER TO DETAILED INSTRUCTIONS FOR MORE INFORMATION.
- » ALWAYS refer to your local building code official prior to installing any railing system to ensure all code and safety requirements are met. Trex cannot be held responsible for improper or non-recommended installations.
- » When installing Trex Signature posts on ACQ, CCA or concrete surfaces, use an appropriate isolation barrier between post and surface (contact local building code official if needed).
- » For installing Trex Signature Post and/or Trex Signature Crossover Posts, see below.
- » For pressure-treated posts, post sleeves, and skirts, see detailed instructions provided with Trex Signature Railing Kits.
- » All Trex Signature stair installations require the use of a 53" (1346 mm) stair post, measured and cut to appropriate length if necessary.
- » If crossover stair post is required, use stair post (again cut to appropriate length if necessary) and use swivel crossover bracket.
- » If installing on concrete, make sure all surfaces are level.

TOOLS AND MATERIALS NEEDED

- » Drill and/or screw gun (hammer drill for concrete)
- » 1/2" (13 mm) drill bit for wood, 3/8" (10 mm) drill bit for concrete
- » Blocking - 2" x 8" (51 mm x 203 mm) pressure-treated Southern Yellow Pine or equivalent
- » Qty: 36 (per post) - 3" pressure-treated compatible wood screws

CODE APPROVED POST APPLICATIONS

POST SIZE	 2.5" (64 mm)
	2.5" (64 mm)
2.5 x 2.5 (64 mm x 64 mm) Post (IRC)	
< 30" height decking	Acceptable (Code Approval not Applicable)
IRC Compliant	Yes
IBC Compliant	No

Installing Trex Signature Posts and/or Trex Signature Crossover Posts on Pressure-Treated Wood Framing (Corner Post Installation)

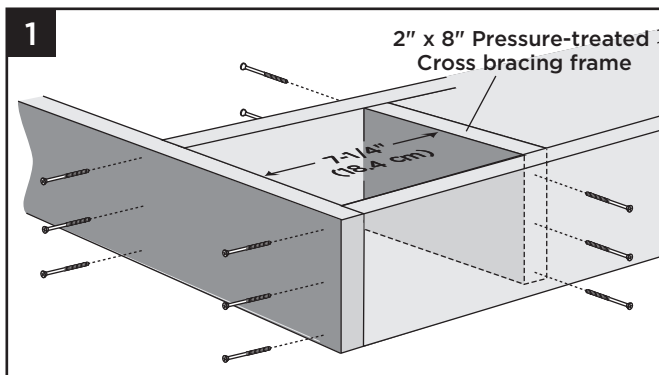

1. Install 2" x 8" (51 mm x 203 mm) cross bracing frame in between joists at 7-1/4" (184 mm). Attach a total of twelve 3" (76 mm) pressure-treated compatible screws (*not provided*).

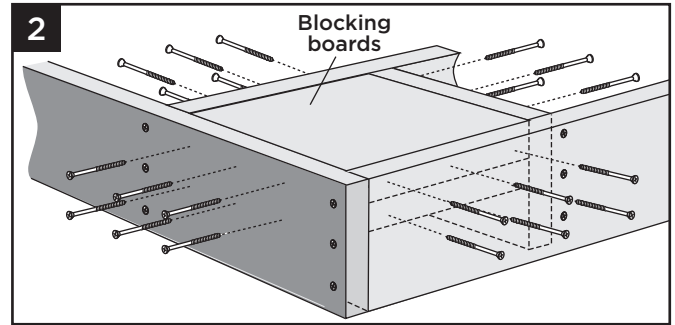

2. Install two 2" x 8" (51 mm x 203 mm) boards as blocking under post location. Securely attach blocking using a total of 24 3" (76 mm) pressure-treated compatible screws (*not provided*).

NOTE: TO ENSURE THE BLOCKING IS FULLY SECURE, USE THE AMOUNT OF SCREWS indicated ABOVE.

TIP: Use two additional screws to "sandwich" blocking boards together for easier attachment to framing.

Line Post Installation

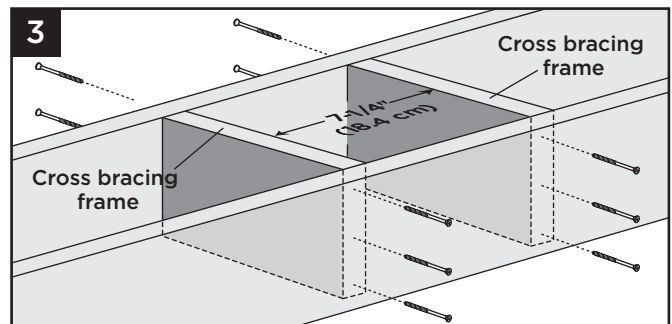

3. Install two 2" x 8" (51 mm x 203 mm) cross bracing frames in between joists at 7-1/4" (184 mm). Attach a total of twelve 3" (76 mm) pressure-treated compatible screws (*not provided*).
4. Install two 2" x 8" (51 mm x 203 mm) boards as

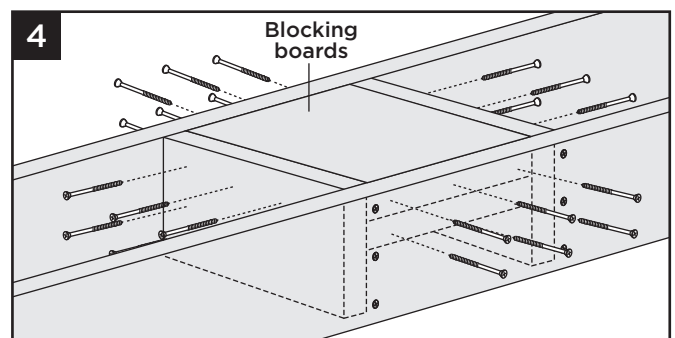

blocking under post location. Securely attach blocking using a total of twenty-four 3" (76 mm) pressure-treated compatible screws (*not provided*).



INSTALLING TREX SIGNATURE® POSTS AND/OR CROSSOVER POSTS ON WOOD OR CONCRETE/*CONTINUED*

NOTES:

» *Metal backplate is only required for 2.5" (64 mm) post in IRC installations. (Consult local code official for more information.)*

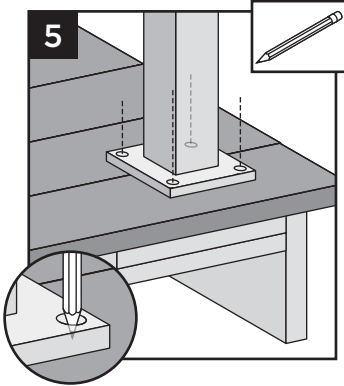

5. Using post as a template, mark locations of holes.
6. Drill through decking and blocking boards using 5/8" diameter bit (long drill bit will be required).

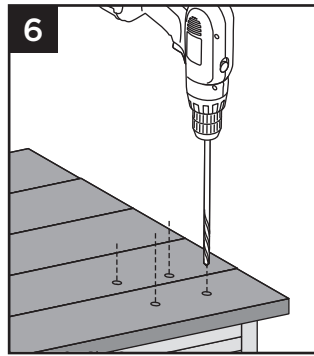

7. Insert the (2) stainless steel barrier strips under the mounting bolt holes. **BARRIER STRIPS ARE REQUIRED ONLY IF ATTACHING POST DIRECTLY TO PRESSURE TREATED FRAMING.**

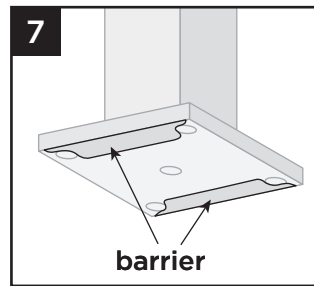

8. Attach posts using four 3/8" x 6" (10 mm x 152 mm) hex cap bolts, washers, and nuts, along with aluminum back plate on underside of blocking. If the project requires IRC compliance, this back plate **MUST** be installed under the decking to ensure this will meet code compliance. Reference SKU part number ALPOSTHWDECK for required hardware and aluminum plate. (Consult local code official for more information on IRC Compliance.)

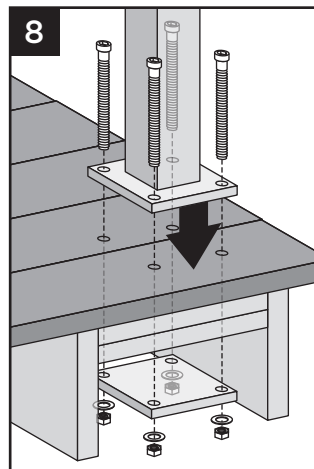

INSTALLING PRESSURE-TREATED POSTS, POST SLEEVES, AND SKIRTS TO USE WITH TREX SIGNATURE RAILING

NOTE: PLEASE REFER TO LOCAL BUILDING CODE REQUIREMENTS PRIOR TO ATTACHING PRESSURE TREATED POSTS. BELOW INSTRUCTIONS ARE GUIDELINES FOR GENERAL REQUIREMENTS.

1. Attach posts using 1/2" (13 mm) carriage bolts.
 - » Minimum joist size is 2" x 8" (51 mm x 203 mm).
 - » Top bolts must be 1" (25 mm) from top of joists.
 - » Bottom bolts must be 5-1/8" (130 mm) from top bolts.

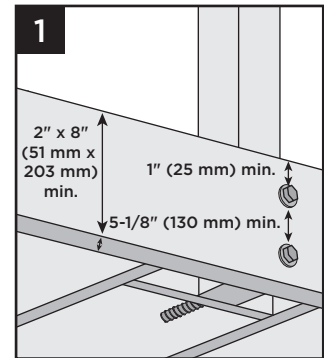

NOTE: Blocking can be added for extra strength.

2. Slide post sleeve skirt over post and down to rest on decking surface. Slide post sleeve over post and position inside post sleeve skirt.

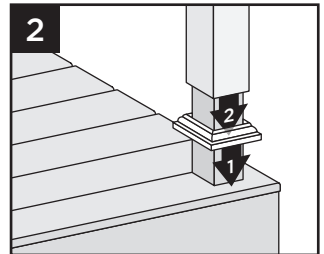

NOTE: Shims can be used to plumb post sleeves.

Installing Trex Signature Posts on Concrete Pre-Drilled Holes

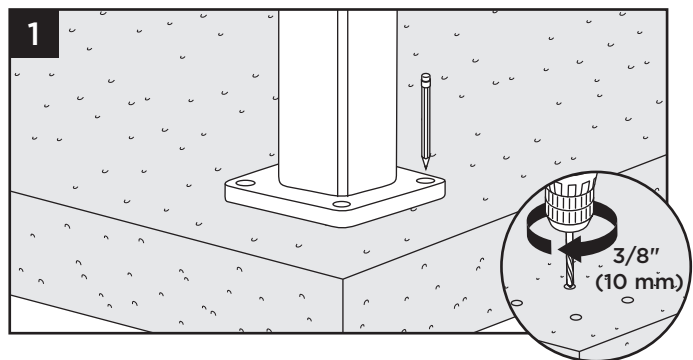

1. Using post as a template, mark locations of the four holes and drill into concrete at least 2-5/8" (67 mm) using a 3/8" (10 mm) masonry bit.

NOTE: You can either set drill bit to correct depth on drill or mark drill bit with tape at required dimension to ensure all holes are drilled at correct depth.

2. Clean out holes to remove all concrete dust using a shop vacuum or other appropriate tool.

INSTALLING TREX SIGNATURE® POSTS AND/OR CROSSOVER POSTS ON WOOD OR CONCRETE/*CONTINUED*

3. Insert (2) stainless steel barrier strips under mounting bolt holes. Use appropriate shims if posts are not plumb. Attach posts using four TREX SUPPLIED 3/8" x 3-3/4" (10 mm x 95 mm) wedge anchors. Reference SKU part number *ALPOSTHWCONC* for required hardware (wedge anchors, washers, and nuts).

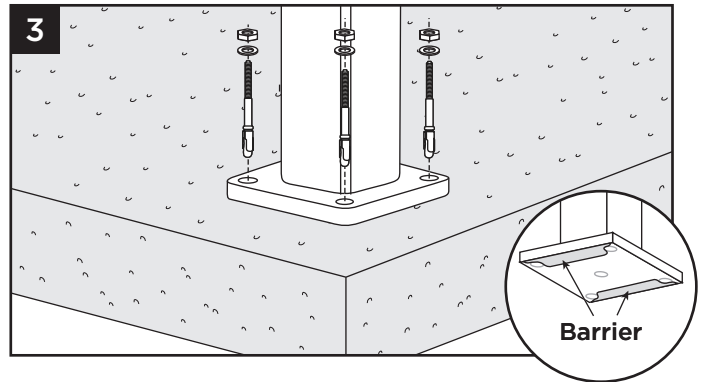

NOTES:

- » When using hammer to tap anchors in place, keep threaded nut at top of anchor in order to not damage threads.
- » Recommended torque for anchors is 20 ft-lbs.

TREX SIGNATURE® RAILING CONFIGURATIONS

Note: See specific installation instructions for attachment of Trex post mounts or Trex Joist Mount Posts prior to installing any railing.

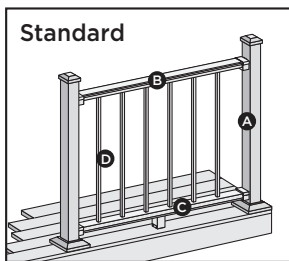

Cutting posts/post sleeves is **NOT** required.

- A. Trex Signature post, pressure-treated post or Trex Post Mounts with Trex post sleeves, or Trex Joist Mount Posts*
- B. Trex Signature top rail
- C. Trex Signature bottom rail
- D. Trex Signature balusters

See page 87 for "How to Install Standard Railing".

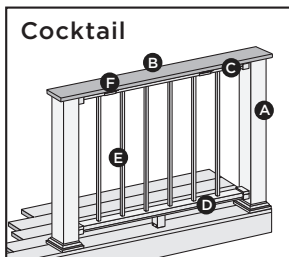

Post sleeves will need to be cut.

- A. Pressure-treated post with Trex post sleeve

NOTE: » Only for use with 4" x 4" (102 mm x 102 mm) post sleeve.
 » Trex Signature Posts, Trex Post Mounts or Joist Mount Posts cannot be used with Trex Signature Cocktail design.

- B. Deck board top rail. **NOTE:** Enhance cannot be used.
- C. Trex Signature top rail
- D. Trex Signature bottom rail
- E. Trex Signature balusters
- F. Trex Signature Cocktail Rail Bracket**

See page 98 for "How to Install Signature Cocktail Railing".

POST SLEEVES WILL NEED TO BE CUT

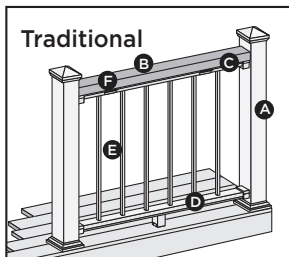

Cutting posts/post sleeves is Not required.

- A. Pressure-treated post, Trex Post Mounts or Trex Joist Mount Post WITH Trex post sleeves.

NOTE: » Trex Signature Posts or Trex Signature Joist Mount Posts cannot be used.

- B. 2 x 4 lateral top rail
- C. Trex Signature top rail
- D. Trex Signature bottom rail
- E. Trex Signature balusters
- F. Trex Signature Cocktail Rail Bracket**

See page 99 for "How to Install Trex Signature Traditional Railing".

** Trex Signature Cocktail Rail brackets (sold separately) are for use with either Trex Signature Traditional or Trex Signature Cocktail designs. For a 6' section, use 4 brackets and screws provided, for 8' section, use 5 brackets and screws provided.

BRACKET HARDWARE - HORIZONTAL APPLICATIONS (INCLUDING HORIZONTAL SWIVEL BRACKETS) TREX SIGNATURE®

HORIZONTAL RAILING HARDWARE

- AA. Lower rail bracket
- BB. Lower rail bracket cover
- CC. Upper rail bracket cover
- DD. Upper rail bracket



FOOT BLOCK COMPONENTS

- EE. Foot block base
- FF. Foot block support

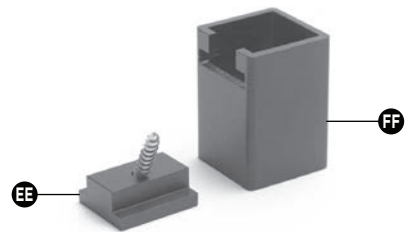

HORIZONTAL SWIVEL HARDWARE

- GG. Swivel base
- HH. Horizontal swivel bracket top rail
- II. Horizontal swivel bracket top rail cover
- JJ. Horizontal swivel bracket bottom rail cover
- KK. Horizontal swivel bracket bottom rail
- LL. Swivel base cover

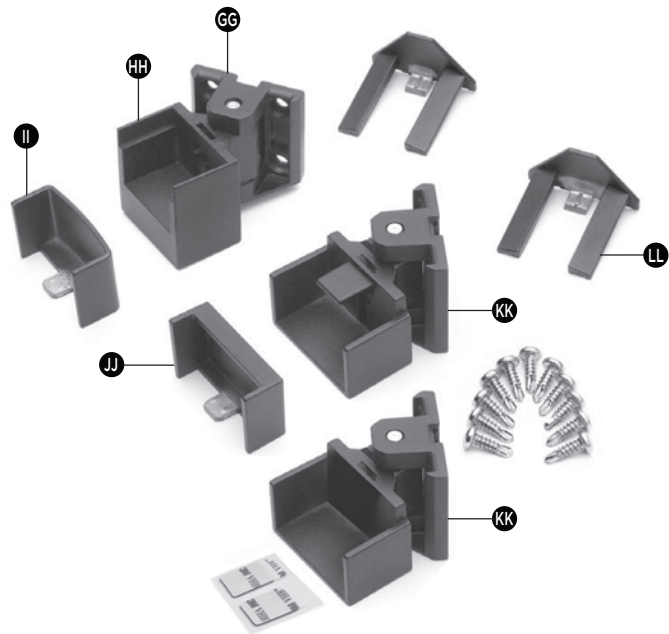

NOTE: Construction methods are always improving. Please refer to www.trex.com for the most up-to-date installation requirements.

HOW TO INSTALL HORIZONTAL RAILING

TREX SIGNATURE®

NOTE: FOR EASE OF INSTALLATION, IT IS RECOMMENDED THAT YOU USE THE TREX SIGNATURE RAIL TEMPLATES TO ATTACH BRACKETS (SOLD SEPARATELY).

Attach Brackets Using Trex Signature Posts

TIP: Use a clamp to help hold brackets in place while fastening with screws.

1. Measure 1-3/8" (3.5 cm) from top of post base plate or 1-7/8" (4.8 cm) from decking surface. Mark with light line.

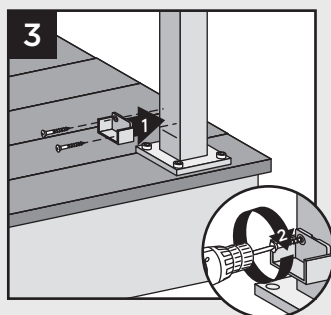
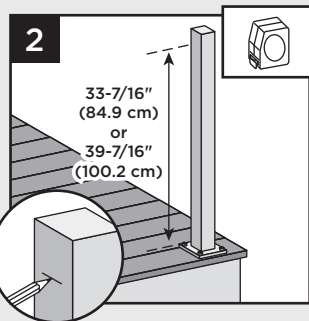
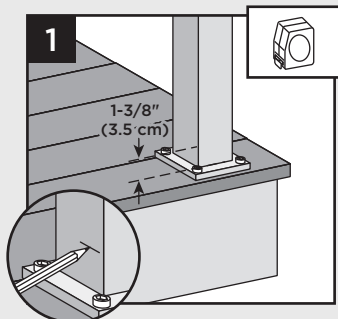

2. Measure up from post base plate 33-7/16" (84.9 cm) for 36" (92 cm) rail height or 39-7/16" (100.2 cm) for 42" (107 cm) rail height. Mark with light line.

NOTE: If measuring from decking surface, measure up 33-15/16" (86.2 cm) for 36" (92 cm) rail height or 39-15/16" (101.4 cm) for 42" (107 cm) rail height.

3. Center lower bracket on post **above** the marked line and attach using two self-tapping screws (provided).
4. Center upper bracket on post **above** marked line and attach using (3) self-tapping screws (provided).

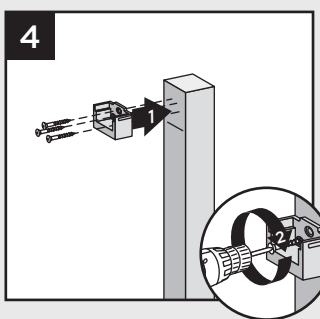

NOTE: Upper bracket is not required on crossover post configuration.

Attach Brackets Using Pressure-Treated Posts and Post Sleeves

TIP: Use a clamp to help hold brackets in place while fastening with screws.

1. Measure 1-7/8" (4.8 cm) up from deck surface to bottom of bracket. Slide skirt up to allow for proper measurement. Mark with light line.

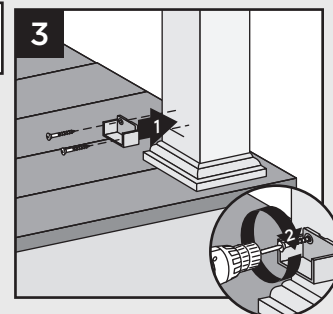
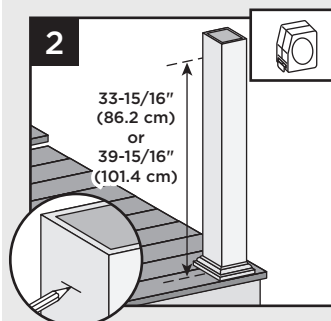
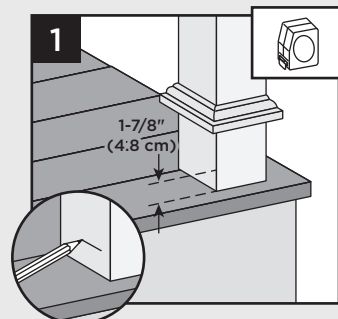

2. Measure up from decking surface 33-15/16" (86.2 cm) for 36" (92 cm) rail height or 39-15/16" (101.4 cm) for 42" (107 cm) rail height. Mark with light line.

NOTE: Push skirt back down onto surface of decking BEFORE ATTACHING BRACKETS.

3. Center lower bracket on post **above** the marked line and attach using two 2" (51 mm) wood screws (provided).
4. Center upper bracket on post **above** marked line and attach using three 2" (51 cm) wood screws (provided).

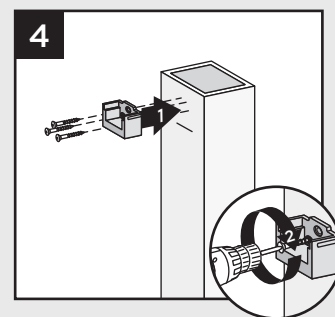

HOW TO INSTALL HORIZONTAL LINE AND CORNER CROSSOVER BRACKETS

TREX SIGNATURE®

PARTS

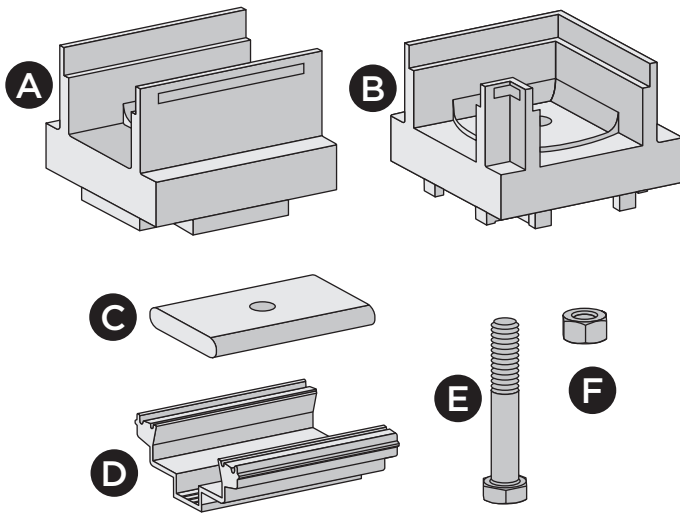

- A. Line Crossover Bracket
- B. Corner Crossover Bracket
- C. Wedge Plate
- D. V-Wedge
- E. 5/16" x 2" SS Bolt
- F. 5/16" SS Nut (1/2" wrench size)

IMPORTANT NOTE REGARDING CUTTING SIGNATURE POSTS:

- » Signature posts must be cut to proper length when using crossover brackets:
 - 36" rail height - cut post to 34" height (measured from deck surface)
 - 42" rail height - cut post to 40" height (measured from deck surface)

Wedge Plate Assembly

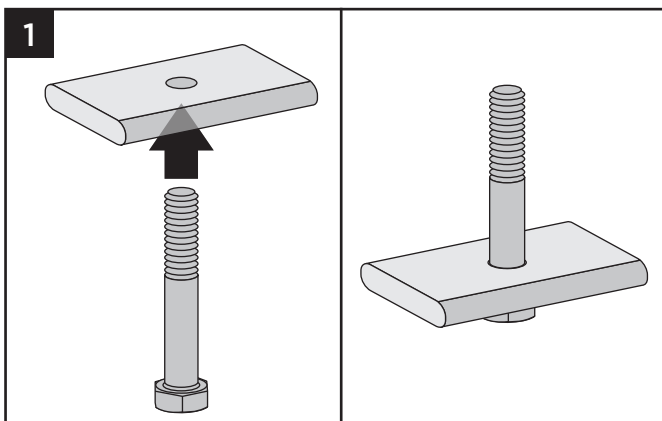

1. Insert the bolt through the hole in wedge plate.

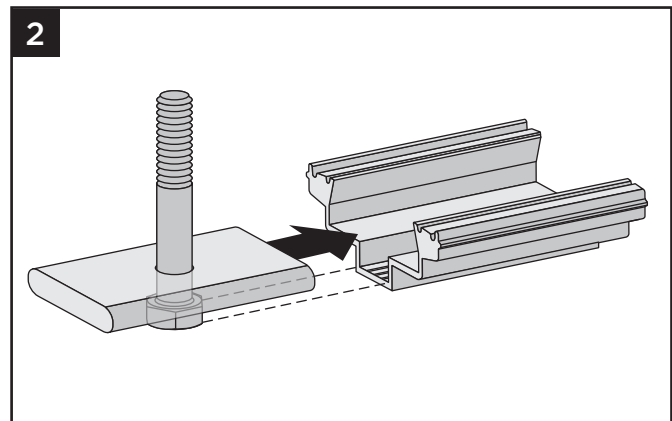

2. Align and insert the wedge plate with bolt into the v-wedge. Slide the wedge plate in until the ends are flush with the ends of the v-wedge.



HOW TO INSTALL HORIZONTAL LINE AND CORNER CROSSOVER BRACKETS/CONTINUED

TREX SIGNATURE®

Installing Wedge Plate Assembly Into Top of Post

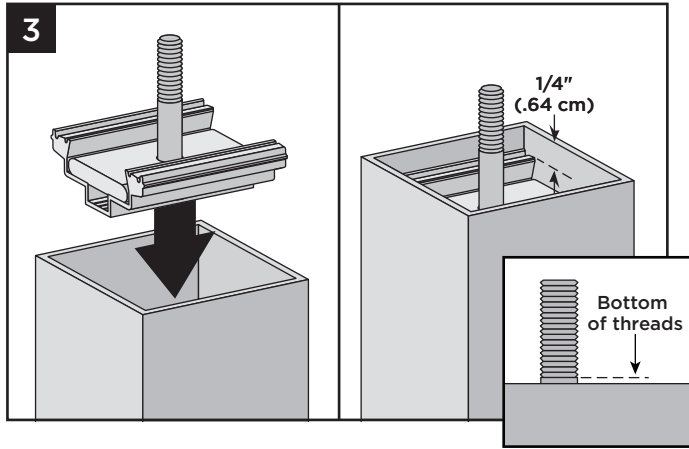

3. Insert assembly (from step 2) into the top of post. Stop when top of v-wedge is about 1/4" into top of post.

Note: Threads of bolt will be slightly above the end of the post.

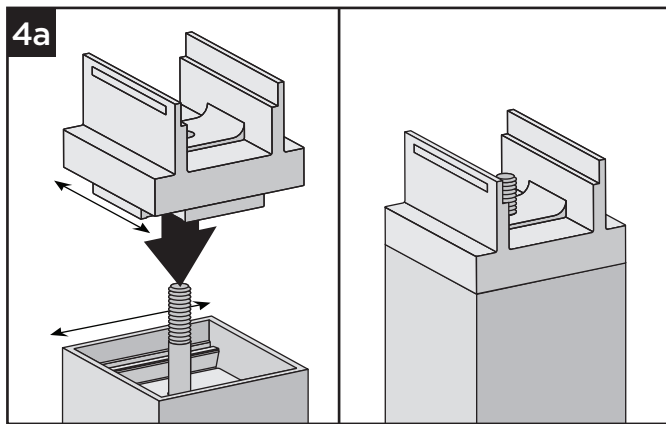

- 4a. Place the line crossover bracket over the bolt onto the end of the post.

IMPORTANT NOTE: For Line Crossover Bracket: Align the bracket such that the rail channel is perpendicular (90°) to the length of the wedge plate assembly.

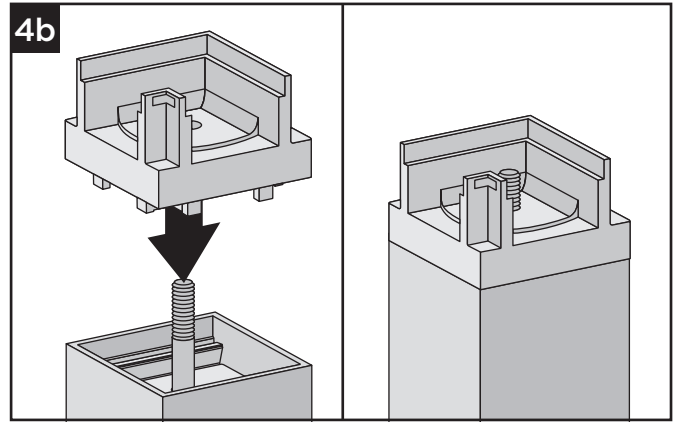

- 4b. Place the corner crossover bracket over the bolt onto the end of the post.

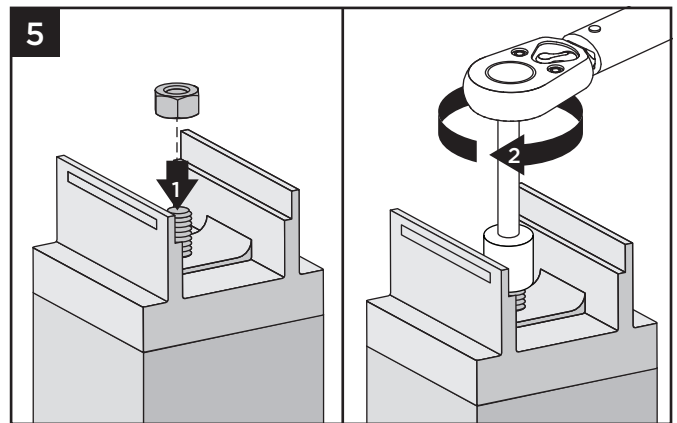

5. Thread the nut onto the bolt. Tighten the nut to **10 ft-lbs** with a torque wrench with 1/2" socket adapter.



HOW TO INSTALL HORIZONTAL RAILING POST TO POST TREX SIGNATURE®

NOTES:

- » TREX SIGNATURE RAILINGS ARE DESIGNED TO BE ATTACHED WITH POSTS INSTALLED AT A CLEAR SPAN OF 6' (1.83 M) OR 8' (2.44 M).
- » IF INSTALLING AT EXACT SPAN LENGTHS OF 6' (1.83 M) OR 8' (2.44 M), AND USING POST-TO-POST CONFIGURATION, THE BOTTOM RAIL WILL NOT NEED TO BE CUT, BUT THE TOP RAIL WILL NEED TO BE MEASURED (MAKING SURE BALUSTERS LINE UP VERTICALLY) AND CUT.
- » FOR ODD SPAN LENGTHS, BOTH TOP RAIL AND BOTTOM RAIL WILL NEED TO BE MEASURED (MAKING SURE BALUSTERS LINE UP VERTICALLY) AND CUT. ENSURE THAT BALUSTERS ARE SPACED WITH AN EQUAL DISTANCE ON EACH SIDE OF THE POST.
- » WHEN RAILINGS ARE CUT TO ODD SPANS, ALL SPANS GREATER THAN 5' (1.52 M) (EXAMPLE: 8' (2.44 M) SPAN CUT INTO ONE 5' (1.52 M) SPAN AND ONE 3' (0.91 M) SPAN) WOULD REQUIRE FOOT BLOCK UNDER 5' (1.52 M) SPAN SINCE SMALLER FIXED BALUSTER IS NO LONGER CENTERED.

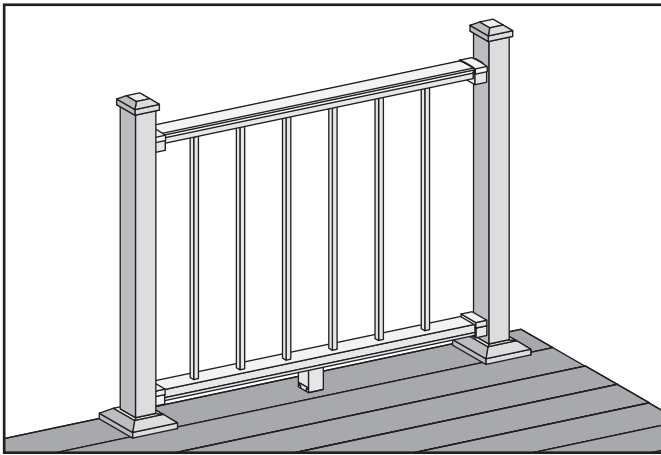

How to Measure and Cut Bottom and Top Railings (When Required)

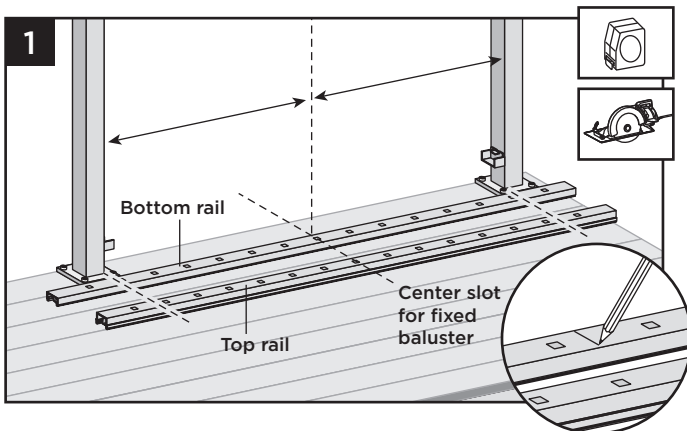

1. Position bottom and top rails between posts and align with bottom bracket. Align the center baluster slot in both rails with the middle of the span between posts.* This will allow an equal number of baluster holes on each side of center slot. Mark bottom rail and top rail at each end (ensure both rails are centered between posts).

* In some cases, due to odd railing spans, the center baluster may need to be offset in one direction to ensure there is enough room at both post locations for balusters to be placed. Review this BEFORE cutting any railings to ensure all balusters are equally spaced.

Cutting Bottom Rail and Bottom Rail Cover

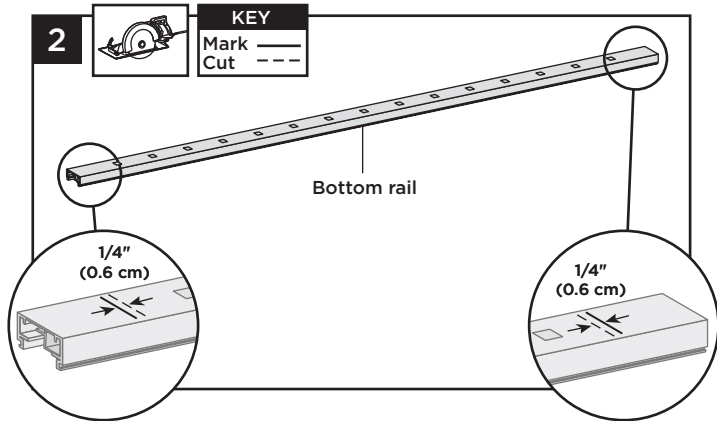

2. Cut each end of bottom rail 1/4" (0.6 cm) shorter than mark on each end to allow for fit into bottom rail brackets.

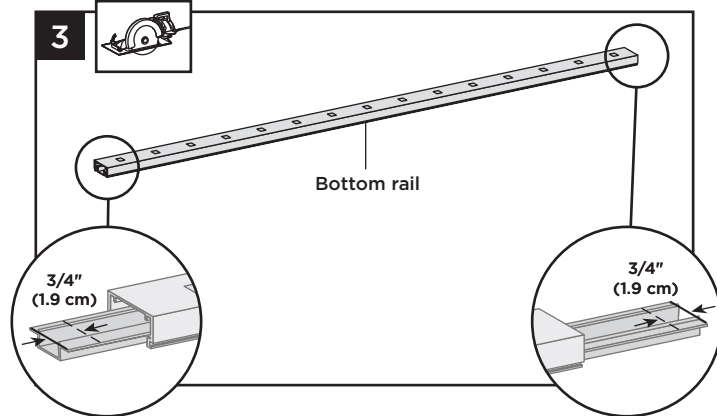

3. Slide rail insert out and cut 3/4" (19 mm) FROM EACH SIDE of insert, then slide back inside rail and center.

4. Mark and cut bottom rail cover 1-1/2" (38 mm) shorter than bottom rail.

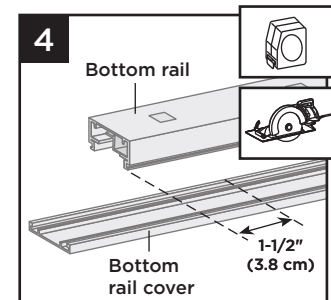

HOW TO INSTALL HORIZONTAL RAILING POST TO POST/CONTINUED

TREX SIGNATURE®

Cutting Top Rail

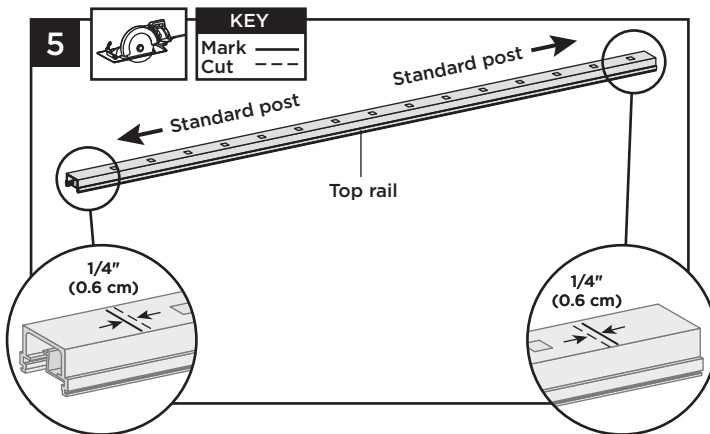

5. Cut each end of top rail 1/4" (0.6 cm) shorter than mark to allow for fit into top rail brackets.

Cutting Top Rail Insert and Cover

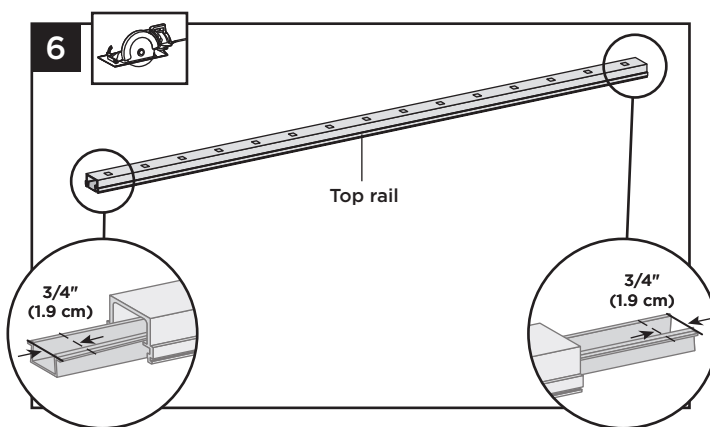

6. Slide rail insert out and cut 3/4" (1.9 cm) FROM EACH SIDE of insert, then slide back inside rail and center.
7. Mark and cut top rail cover same length as top rail for all top rail configurations.

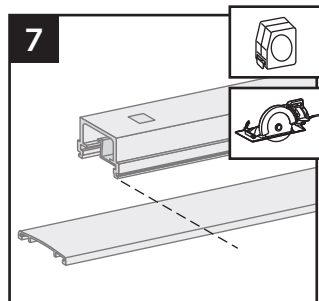

Attaching Center Baluster to Bottom Rail

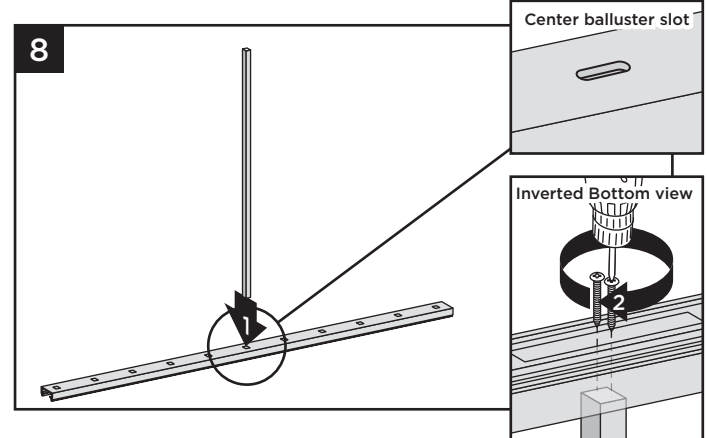

8. Attach shorter, center baluster in center slot in bottom rail using two #8 x 1-1/4" (3.2 cm) screws (provided).

Attaching Bottom Rail Cover

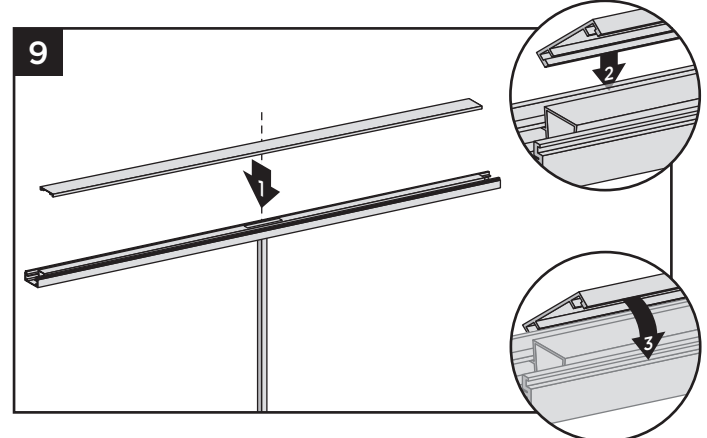

9. Attach "flat" bottom rail cover to bottom rail by first centering cover on bottom rail (this will allow gap on each end of bottom rail for placement into brackets). Align cover on one side of bottom rail in slot on side of rail. Then starting from one end of rail snap cover onto opposing slot working down the length of rail. In some cases, **GENTLE** tapping with a **rubber mallet** may facilitate fastening.



HOW TO INSTALL HORIZONTAL RAILING POST TO POST/CONTINUED TREX SIGNATURE®

Attaching Foot Block (when required)

Required **ONLY** for All Clear Span Applications over 6' (1.83 m) when shorter fixed baluster is centered, or unsupported spans greater than 5' (1.52 m) (example: 8' (2.44 m) span cut into one 5' (1.52 m) span and one 3' (0.91 m) span would require foot block under 5' (1.52 m) span since shorter fixed baluster is no longer centered). Included with 8' (2.44 m) railing kits.

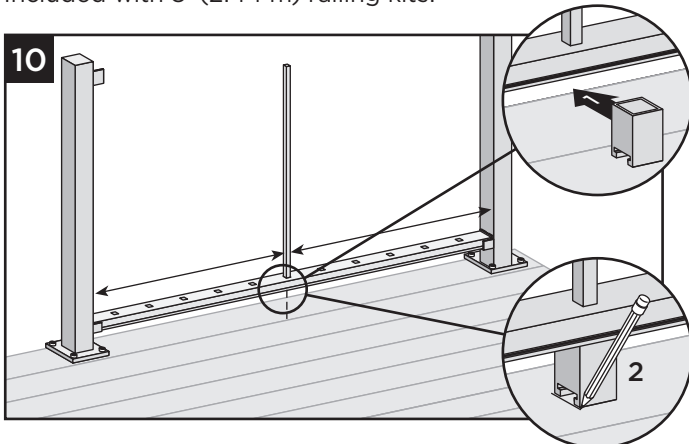

10. Temporarily set bottom rail into bottom brackets, and place foot block under center of bottom rail. Mark to provide placement location of base. Remove bottom rail.

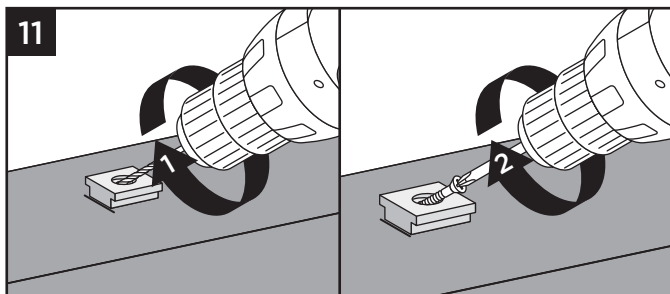

11. Place base (smaller side facing down) on decking surface. Pre-drill using a 3/16" bit. Attach base of foot block using one screw at an angle through base and into decking.

12. After attached, use a **rubber mallet** along with **scrap piece of wood** to tap foot block until it locks into place.

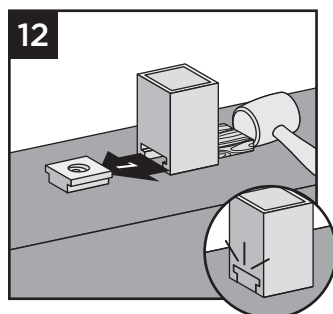

Attaching Bottom Rail to Brackets

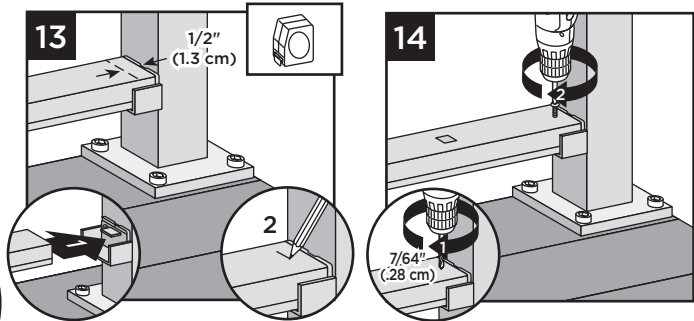

13. Set bottom rail into bottom brackets. Tabs on brackets will be inside of bottom rail (not shown when railing is attached). To ensure fit into tab, measure and mark 1/2" (1.3 cm) out from side of post.

14. Attach bottom rail to bottom bracket by fastening through marked measurement on top of rail into tab on bottom bracket using one self-tapping screw each side (*provided*).

NOTE: Pre-drilling is required (7/64" [0.28 cm] drill bit) for attachment of railing to bracket.

Installing Remaining Balusters into Bottom Rail

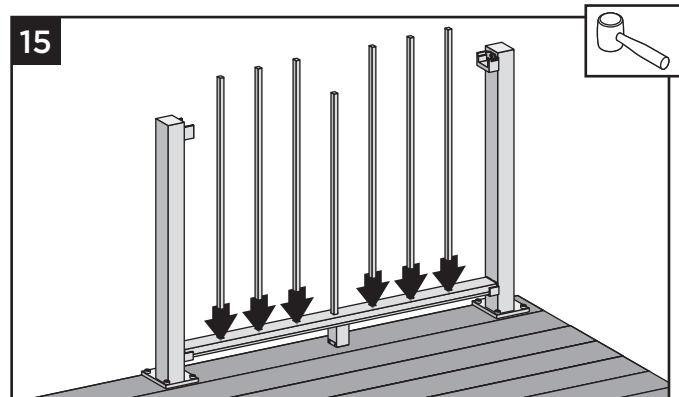

15. Place remaining balusters into holes in lower rail by snapping fully into place. In some cases, **GENTLE** tapping with a **rubber mallet** may facilitate fastening.

HOW TO INSTALL HORIZONTAL RAILING POST TO POST/CONTINUED

TREX SIGNATURE®

Attach Upper Railings

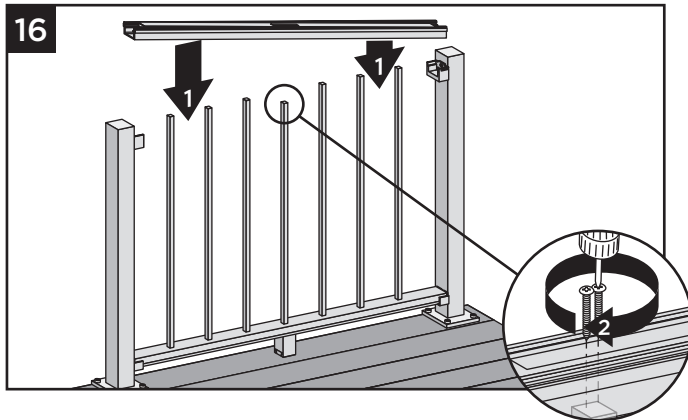

16. Working from one end of upper rail, snap balusters into upper rail working down length of rail. Fasten center baluster into center slot using two #8 x 1-1/4" (3.2 cm) screws (provided).

17. Fasten upper rail to each bracket by installing screws diagonally through upper rail into bracket using two self-tapping screws each side (provided).

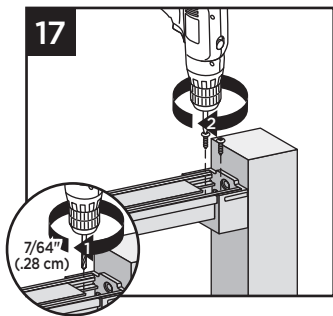

NOTE: Pre-drilling is required (7/64" [0.28 cm] drill bit) for attachment of railing to bracket.

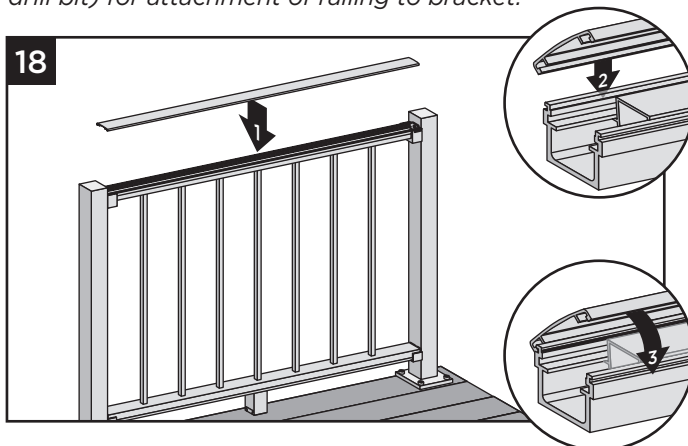

18. Attach "crowned" upper rail cover to upper rail by aligning cover on one side of rail. Then starting from one end of rail, snap cover onto opposing slot working down length of rail. **GENTLE** tapping with a **rubber mallet** may facilitate fastening.

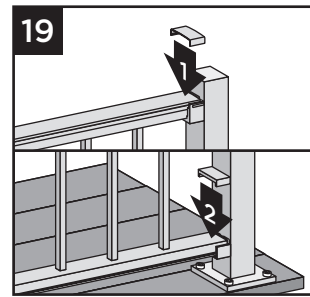

19. Attach corresponding bracket covers over opening in upper and bottom rails.

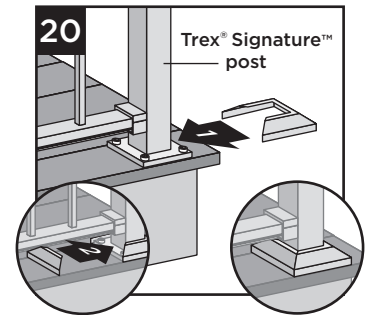

20. Attach provided post skirt to bottom of posts when using Trex Signature posts.

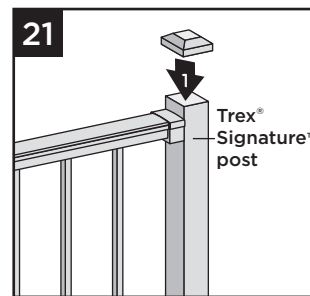

21. Attach post caps to Trex Signature posts. (Use of **rubber mallet** may be required for secure attachment.)

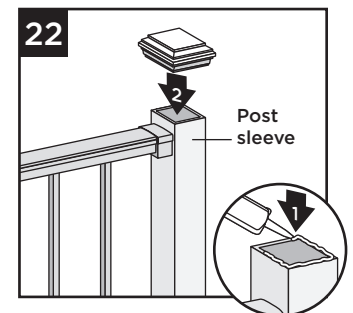

22. Attach post caps to post sleeves using external grade PVC construction adhesive (apply adhesive on the inside self-centering/corner tabs).

HOW TO INSTALL HORIZONTAL RAILING POST TO CROSSOVER POST TREX SIGNATURE®

NOTES:

- » TREX SIGNATURE RAILINGS ARE DESIGNED TO BE ATTACHED WITH POSTS INSTALLED AT A CLEAR SPAN OF 6' (1.83 M) OR 8' (2.44 M).
- » IF INSTALLING AT EXACT SPAN LENGTHS OF 6' (1.83 M) OR 8' (2.44 M), AND USING POST-TO-CROSSOVER POST CONFIGURATION, THE BOTTOM RAIL WILL NOT NEED TO BE CUT, BUT THE TOP RAIL WILL NEED TO BE MEASURED (MAKING SURE BALUSTERS LINE UP VERTICALLY) AND CUT.
- » AT ALL FINAL END POST CONFIGURATIONS, TOP RAIL WILL NEED TO BE MEASURED (MAKING SURE BALUSTERS LINE UP VERTICALLY) AND CUT.
- » FOR ODD SPAN LENGTHS, BOTH TOP RAIL AND BOTTOM RAIL WILL NEED TO BE MEASURED (MAKING SURE BALUSTERS LINE UP VERTICALLY) AND CUT. ENSURE THAT BALUSTERS ARE SPACED WITH AN EQUAL DISTANCE ON EACH SIDE OF THE POST.
- » WHEN RAILINGS ARE CUT TO ODD SPANS, ALL SPANS GREATER THAN 5' (1.52 M) (EXAMPLE: 8' (2.44 M) SPAN CUT INTO ONE 5' (1.52 M) SPAN AND ONE 3' (0.91 M) SPAN) WOULD REQUIRE FOOT BLOCK UNDER 5' (1.52 M) SPAN SINCE SMALLER FIXED BALUSTER IS NO LONGER CENTERED.

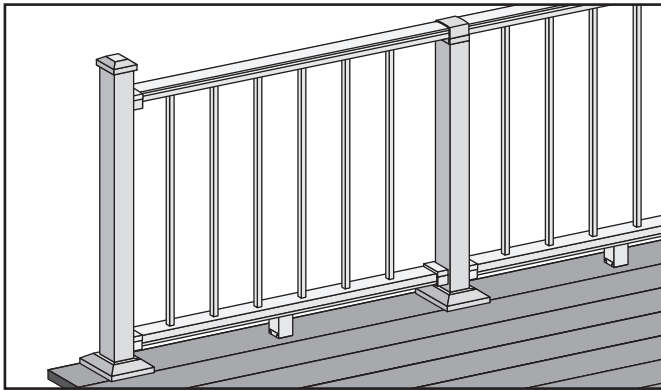

How to Measure, Mark and Cut Bottom and Top Railings (When Required)

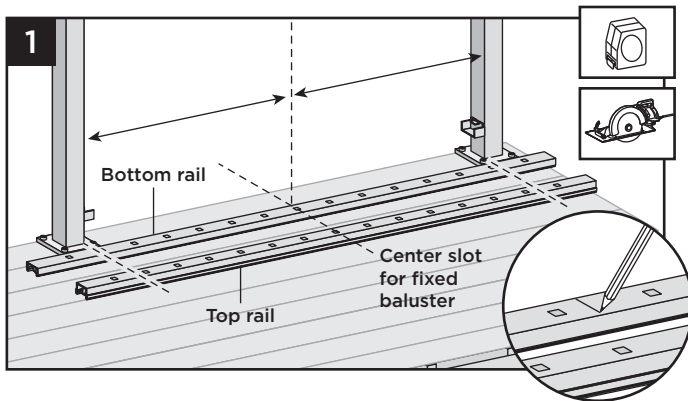

Important: DO NOT cut top rail the same length as bottom rail.

1. Position bottom and top rails between posts and align with bottom bracket. Align the center baluster slot in both rails with the middle of the span between posts.* This will allow an equal number of baluster holes on each side of center slot. Mark bottom rail and top rail at each end (ensure both rails are centered between posts).

* In some cases, due to odd railing spans, the center baluster may need to be offset in one direction to ensure there is enough room at both post locations for balusters to be placed. Review this BEFORE cutting any railings to ensure all balusters are equally spaced.

Cutting Bottom Rail and Bottom Rail Cover ONLY

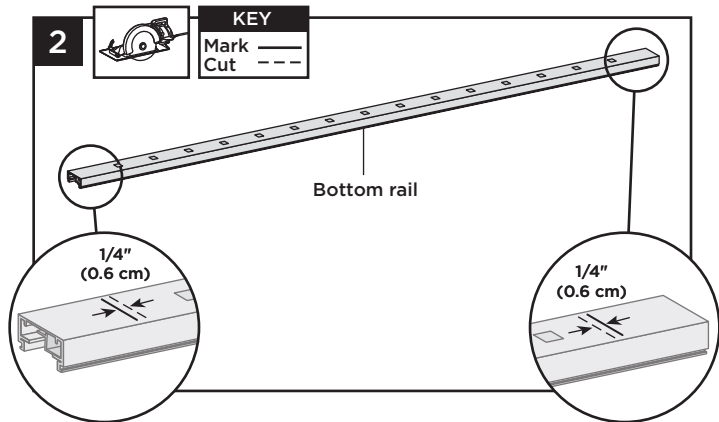

2. Cut each end of bottom rail 1/4" (0.6 cm) shorter than mark on each end to allow for fit into bottom rail brackets.

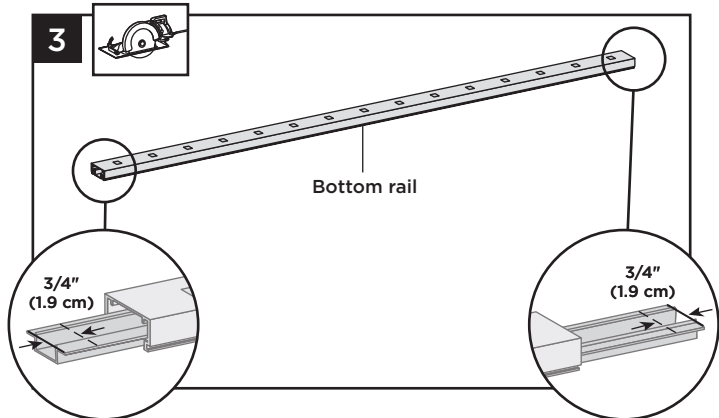

3. Slide rail insert out and cut 3/4" (1.9 cm) FROM EACH SIDE of insert, then slide back inside rail and center.

4. Mark and cut bottom rail cover 1-1/2" (3.8 cm) shorter than bottom rail.

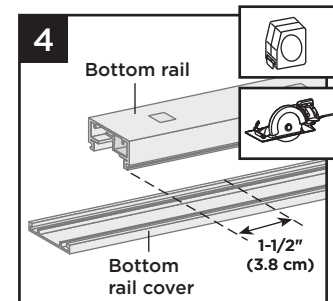

HOW TO INSTALL HORIZONTAL RAILING POST TO CROSSOVER POST/CONTINUED

TREX SIGNATURE®

Cutting Top Rail

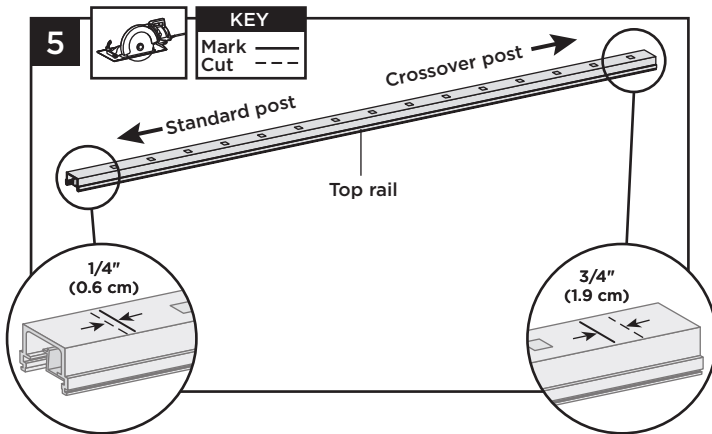

5. Top rail must be cut differently on each side of the rail. Railing side that attaches to standard post should be cut 1/4" (0.6 cm) shorter than the mark to allow for fit into top rail bracket. Railing side that attaches to the crossover post should be cut 3/4" (1.9 cm) **LONGER** than the mark to allow for fit into the crossover post bracket.

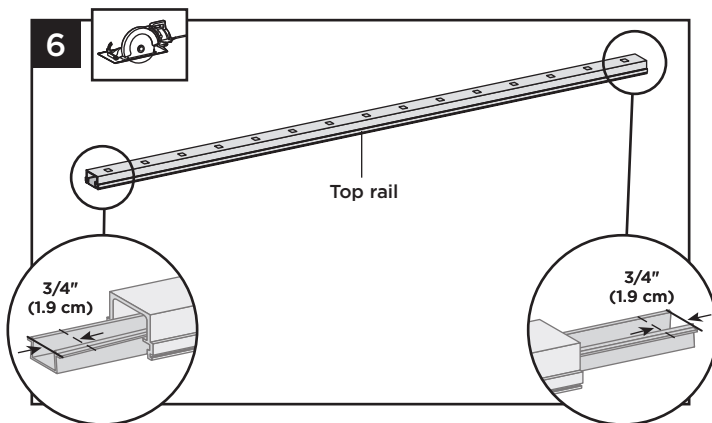

Cutting Top Rail Insert and Cover

6. Slide rail insert out and cut 3/4" (1.9 cm) **FROM EACH SIDE** of insert, then slide back inside rail and center.
7. Mark and cut top rail cover same length as top rail for all top rail configurations.

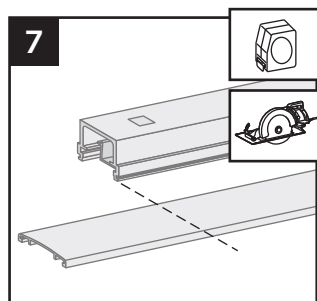

Attaching Center Baluster to Bottom Rail

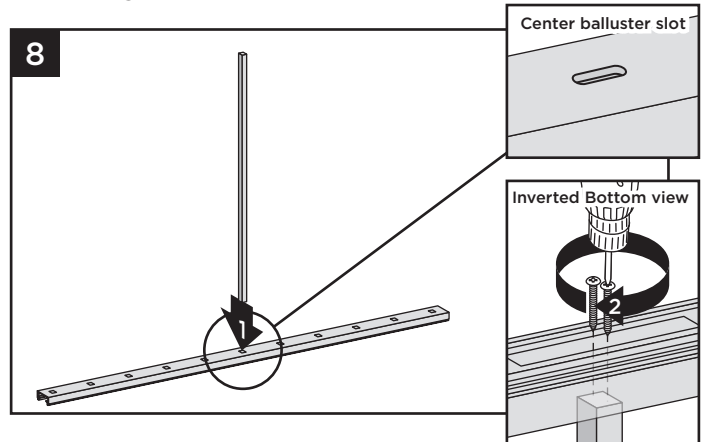

8. Attach shorter, center baluster in center slot in bottom rail using two #8 x 1-1/4" (3.2 cm) screws (provided).

Attaching Bottom Rail Cover

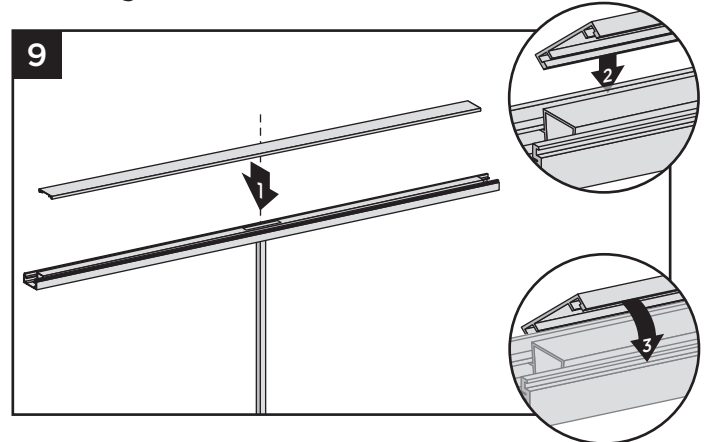

9. Attach "flat" bottom rail cover to bottom rail by first centering cover on bottom rail (this will allow gap on each end of bottom rail for placement into brackets). Align cover on one side of bottom rail in slot on side of rail. Then starting from one end of rail snap cover onto opposing slot working down the length of rail. In some cases, **GENTLE** tapping with a **rubber mallet** may facilitate fastening.

10. Attaching Foot Block (when required)

See instructions on page 89.

HOW TO INSTALL HORIZONTAL RAILING POST TO CROSSOVER POST/CONTINUED

TREX SIGNATURE®

Attaching Bottom Rail to Brackets

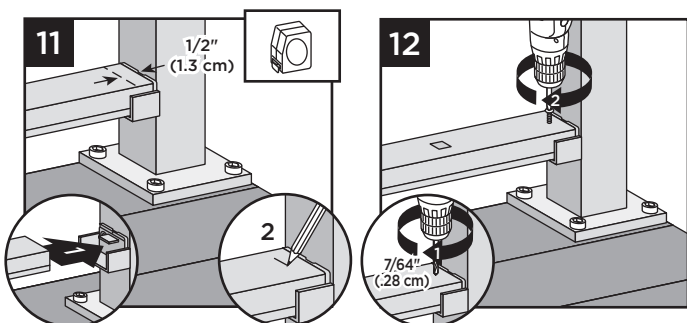

11. Set bottom rail into bottom brackets. Tabs on brackets will be inside of bottom rail (not shown when railing is attached). To ensure fit into tab, measure and mark 1/2" (1.3 cm) out from side of post.
12. Attach bottom rail to bottom bracket by fastening through marked measurement on top of rail into tab on bottom bracket using one self-tapping screw each side (*provided*).

NOTE: Pre-drilling is required (7/64" [0.28 cm] drill bit) for attachment of railing to bracket.

Installing Remaining Balusters into Bottom Rail

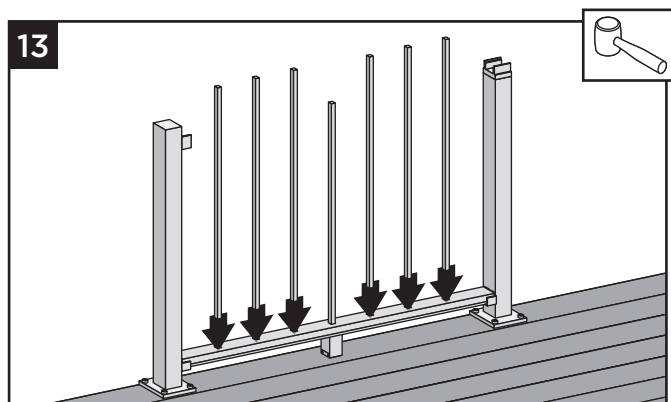

13. Place remaining balusters into holes in lower rail by snapping fully into place. In some cases, **GENTLE** tapping with a **rubber mallet** may facilitate fastening.

Attach Upper Railings

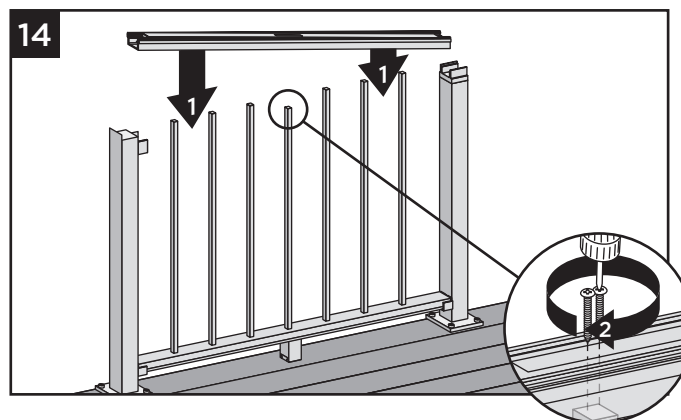

14. Working from one end of upper rail, snap balusters into upper rail working down length of rail. Fasten center baluster into center slot using two #8 x 1-1/4" (3.2 cm) screws (*provided*).
15. At post location, fasten upper rail to each bracket by installing screws diagonally through upper rail into bracket using two self-tapping screws each side (*provided*).

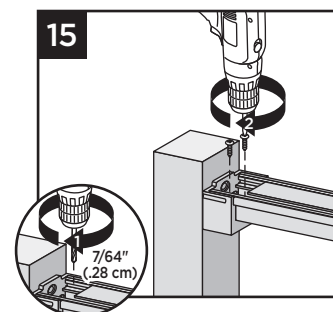

NOTE: Pre-drilling is required (7/64" [0.28 cm] drill bit) for attachment of railing to bracket.

16. At crossover post location, fasten upper rail to crossover post by installing screws diagonally through upper rail into post using two self-tapping screws each side (*provided*).

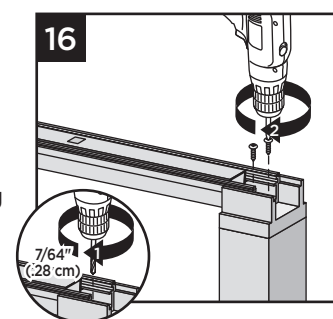

NOTE: Pre-drilling is required (7/64" [0.28 cm] drill bit) for attachment of railing to bracket.

HOW TO INSTALL HORIZONTAL RAILING POST TO CROSSOVER POST POST/CONTINUED TREX SIGNATURE®

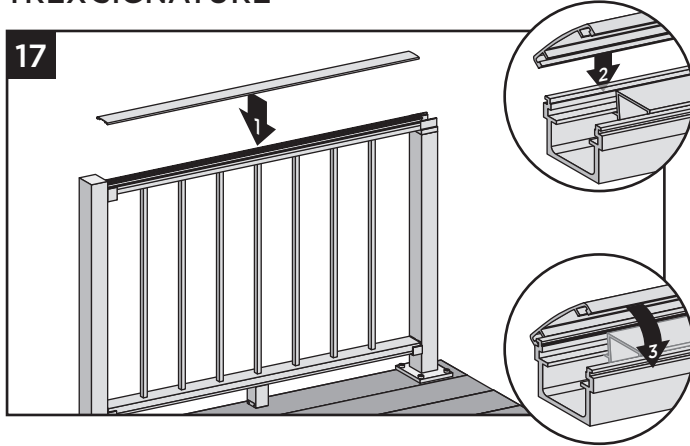

17. Attach “crowned” upper rail cover to upper rail by aligning cover on one side of rail. Then starting from one end of rail, snap cover onto opposing slot working down length of rail. In some cases, **GENTLE** tapping with a **rubber mallet** may facilitate fastening.

Attachment of Bracket Covers, Skirts, and Caps

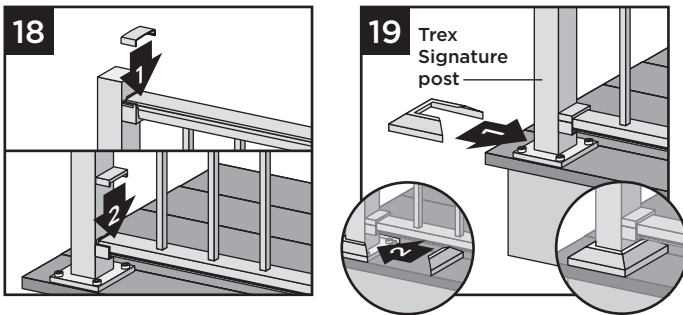

18. Attach corresponding bracket covers over opening in upper and bottom rails.
19. Attach provided post skirt to bottom of posts when using Trex Signature posts.

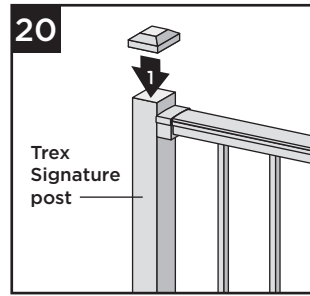

20. Attach post caps to Trex Signature posts. (Use of **rubber mallet** may be required for secure attachment.)

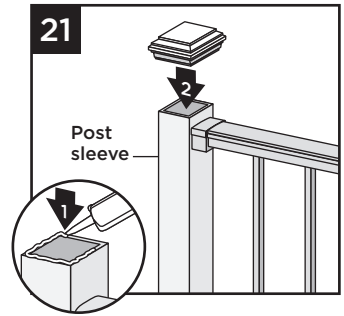

21. Attach post caps to post sleeves using external grade PVC construction adhesive (apply adhesive on the inside self-centering/corner tabs).

22. For crossover post configuration, attach crossover post cap to crossover post.

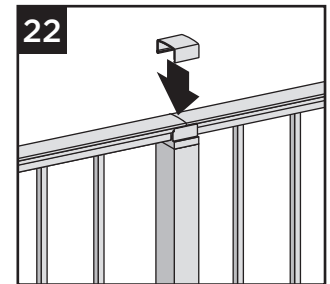

HOW TO INSTALL HORIZONTAL RAILING CROSSOVER POST TO CROSSOVER POST TREX SIGNATURE®

NOTES:

- » TREX SIGNATURE RAILINGS ARE DESIGNED TO BE ATTACHED WITH POSTS INSTALLED AT A CLEAR SPAN OF 6' (1.83 M) OR 8' (2.44 M).
- » IF INSTALLING AT EXACT SPAN LENGTHS OF 6' (1.83 M) OR 8' (2.44 M), AND USING POST-TO-CROSSOVER POST CONFIGURATION, THE BOTTOM RAIL WILL NOT NEED TO BE CUT, BUT THE TOP RAIL WILL NEED TO BE MEASURED (MAKING SURE BALUSTERS LINE UP VERTICALLY) AND CUT.
- » FOR ODD SPAN LENGTHS, BOTH TOP RAIL AND BOTTOM RAIL WILL NEED TO BE MEASURED (MAKING SURE BALUSTERS LINE UP VERTICALLY) AND CUT. ENSURE THAT BALUSTERS ARE SPACED WITH AN EQUAL DISTANCE ON EACH SIDE OF THE POST.
- » WHEN RAILINGS ARE CUT TO ODD SPANS, ALL SPANS GREATER THAN 5' (1.52 M) (EXAMPLE: 8' (2.44 M) SPAN CUT INTO ONE 5' (1.52 M) SPAN AND ONE 3' (0.91 M) SPAN) WOULD REQUIRE FOOT BLOCK UNDER 5' (1.52 M) SPAN SINCE SMALLER FIXED BALUSTER IS NO LONGER CENTERED.

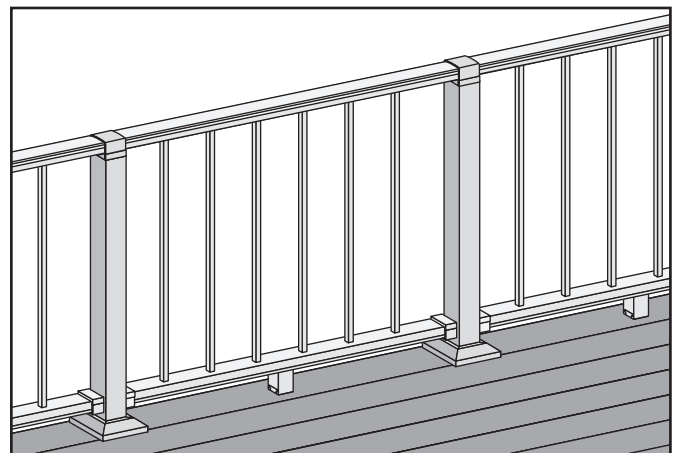

NOTE: Construction methods are always improving. Please refer to www.trex.com for the most up-to-date installation requirements.

HOW TO INSTALL HORIZONTAL RAILING CROSSOVER POST TO CROSSOVER POST/CONTINUED

TREX SIGNATURE®

How to Measure, Mark and Cut Bottom and Top Railings (When Required)

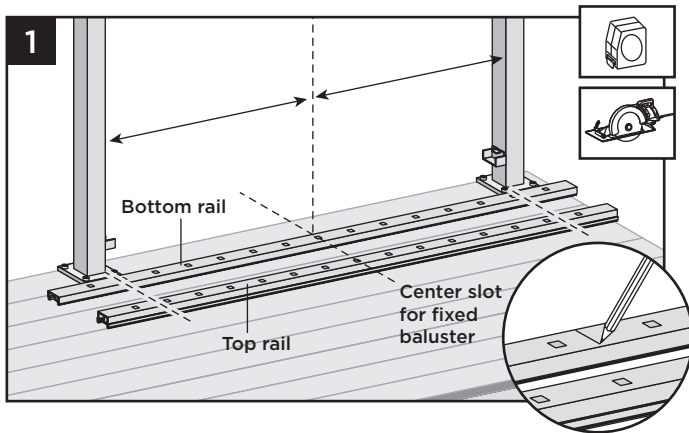

Important: DO NOT cut top rail the same length as bottom rail.

1. Position bottom and top rails between posts and align with bottom bracket. Align the center baluster slot in both rails with the middle of the span between posts.* This will allow an equal number of baluster holes on each side of center slot. Mark bottom rail and top rail at each end (ensure both rails are centered between posts).

* In some cases, due to odd railing spans, the center baluster may need to be offset in one direction to ensure there is enough room at both post locations for balusters to be placed. Review this **BEFORE** cutting any railings to ensure all balusters are equally spaced.

Cutting Bottom Rail and Bottom Rail Cover ONLY

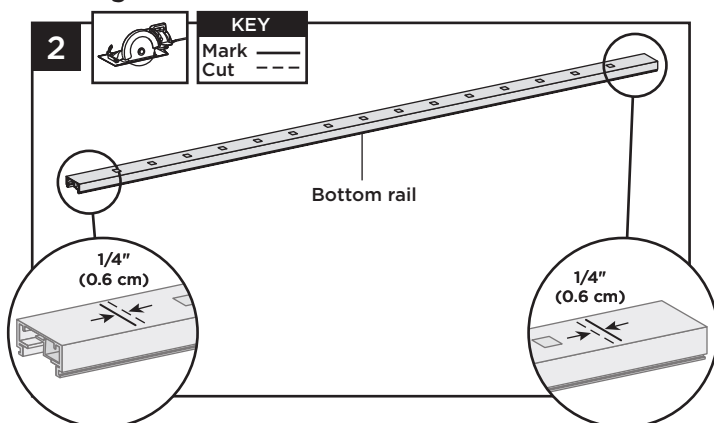

2. Cut each end of bottom rail 1/4" (0.6 cm) shorter than mark on each end to allow for fit into bottom rail brackets.

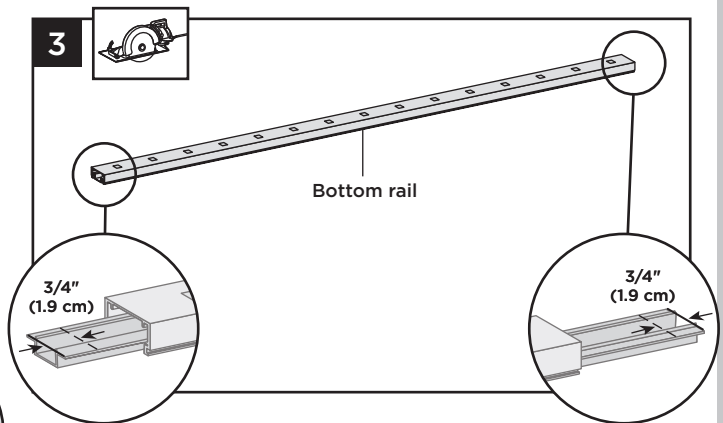

3. Slide rail insert out and cut 3/4" (1.9 cm) **FROM EACH SIDE** of insert, then slide back inside rail and center.

4. Mark and cut bottom rail cover 1-1/2" (3.8 cm) shorter than bottom rail.

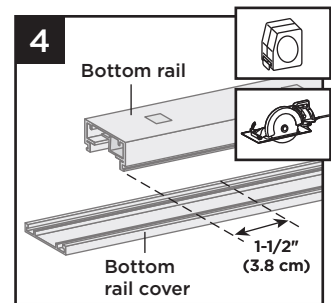

Cutting Top Rail

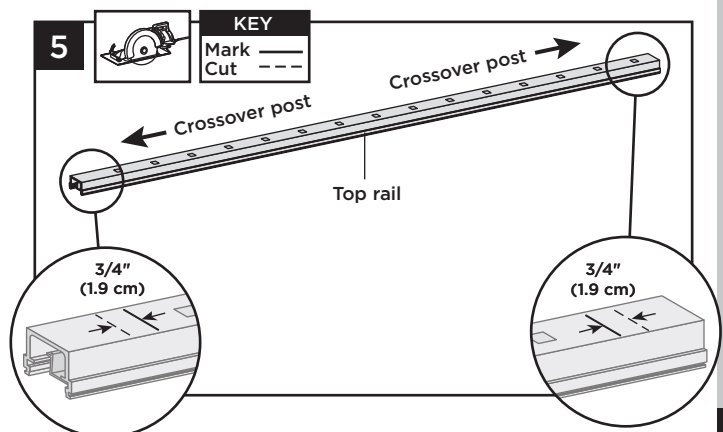

5. Cut each end of top rail 3/4" (1.9 cm) **LONGER** than the mark to allow for fit into the crossover post bracket on each side.

HOW TO INSTALL HORIZONTAL RAILING CROSSOVER POST TO CROSSOVER POST/*CONTINUED*

TREX SIGNATURE®

Cutting Top Rail Insert and Cover

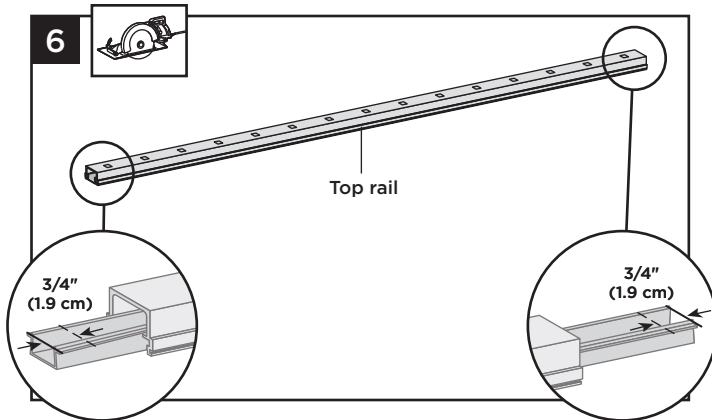

6. Slide rail insert out and cut 3/4" (1.9 cm) **FROM EACH SIDE** of insert, then slide back inside rail and center.
7. Mark and cut top rail cover same length as top rail for all top rail configurations.

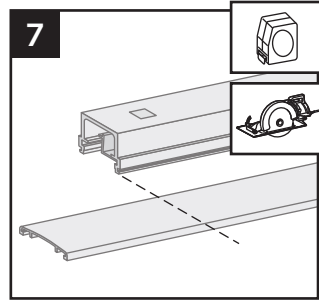

Attaching Center Baluster to Bottom Rail

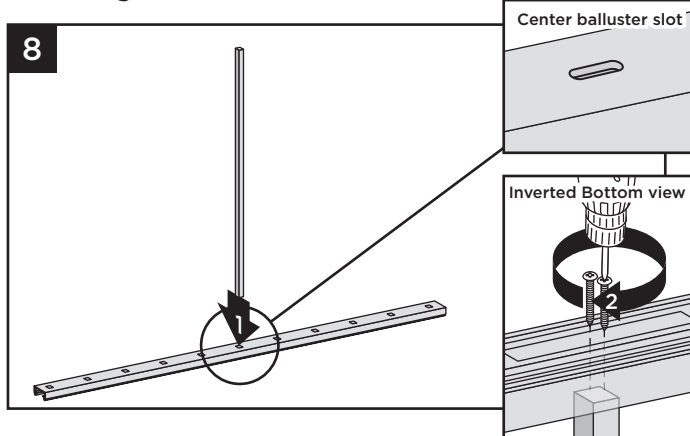

8. Attach shorter, center baluster in center slot in bottom rail using two #8 x 1-1/4" (3.2 cm) screws (*provided*).

Attaching Bottom Rail Cover and

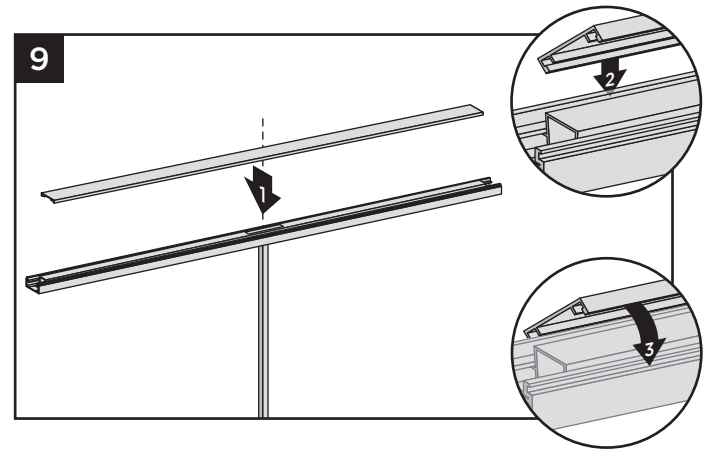

Bottom Rail to Brackets

9. Attach "flat" bottom rail cover to bottom rail by first centering cover on bottom rail (this will allow gap on each end of bottom rail for placement into brackets). Align cover on one side of bottom rail in slot on side of rail. Then starting from one end of rail snap cover onto opposing slot working down the length of rail. In some cases, **GENTLE** tapping with a **rubber mallet** may facilitate fastening.

10. Attaching Foot Block (when required)

See instructions on page 89.

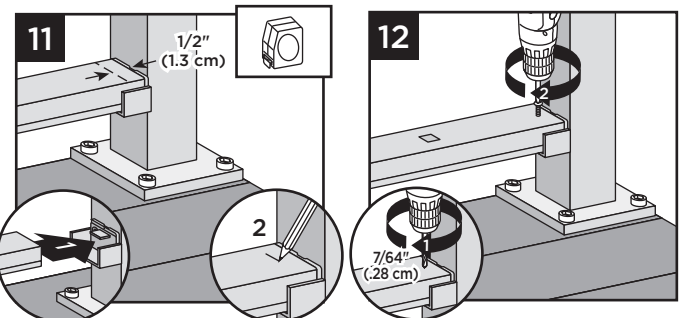

Attaching Bottom Rail to Brackets

11. Set bottom rail into bottom brackets. Tabs on brackets will be inside of bottom rail (not shown when railing is attached). To ensure fit into tab, measure and mark 1/2" (1.3 cm) out from side of post.
12. Attach bottom rail to bottom bracket by fastening through marked measurement on top of rail into tab on bottom bracket using one self-tapping screw each side (*provided*).

NOTE: Pre-drilling is required (7/64" [0.28 cm] drill bit) for attachment of railing to bracket.



HOW TO INSTALL HORIZONTAL RAILING CROSSOVER POST TO CROSSOVER POST/CONTINUED

TREX SIGNATURE®

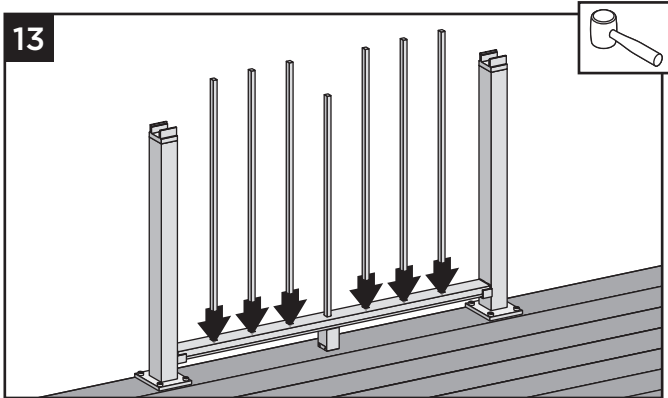

Installing Remaining Balusters into Bottom Rail
 13. Place remaining balusters into holes in lower rail by snapping fully into place. In some cases, **GENTLE** tapping with a **rubber mallet** may facilitate fastening.

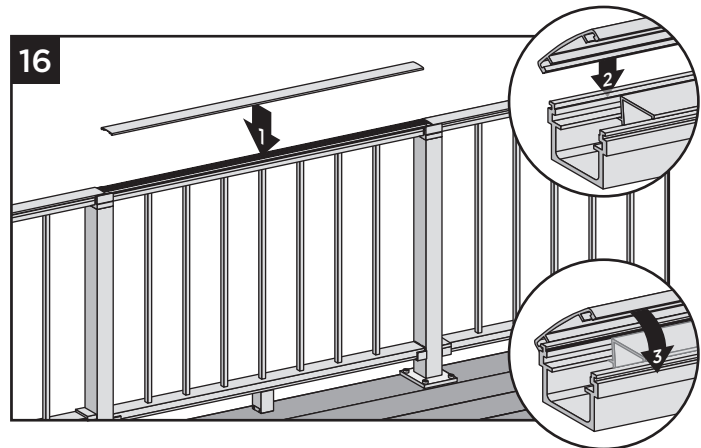

NOTE: Pre-drilling is required (7/64" [0.28 cm] drill bit) for attachment of railing to bracket.

16. Attach "crowned" upper rail cover to upper rail by aligning cover on one side of rail. Then starting from one end of rail, snap cover onto opposing slot working down length of rail. **GENTLE** tapping with a **rubber mallet** may facilitate fastening.

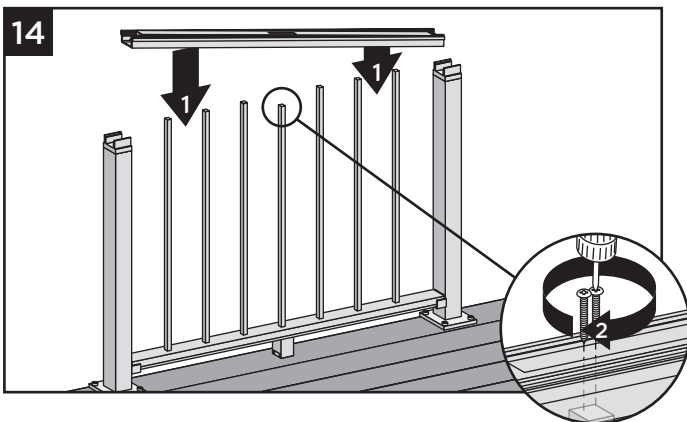

Attach Upper Railings
 14. Working from one end of upper rail, snap balusters into upper rail working down length of rail. Fasten center baluster into center slot using two #8 x 1-1/4" (3.2 cm) screws (provided).

NOTE: Pre-drilling is required (7/64" [0.28 cm] drill bit) for attachment of railing to bracket.

15. At post locations, fasten upper rail to crossover post by installing screws diagonally through upper rail into post using two self-tapping screws each side (provided).

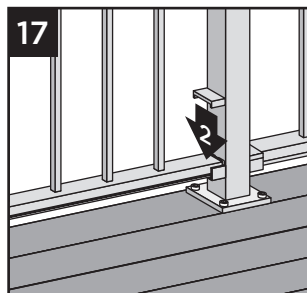
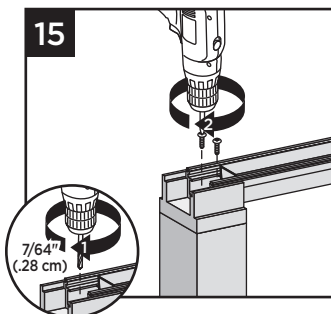

Attachment of Bracket Covers, Skirts, and Caps
 17. Attach corresponding bracket covers over opening in bottom rails.

18. Attach provided post skirt to bottom of posts when using Trex Signature posts.

19. Attach crossover post cap to crossover post.

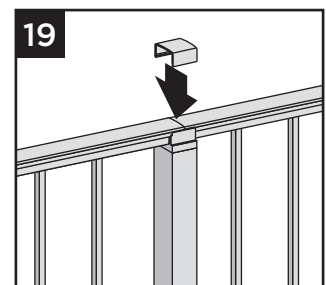
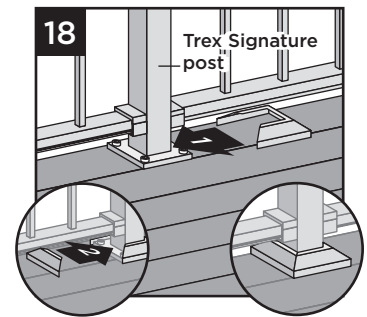

HOW TO INSTALL TREX SIGNATURE® COCKTAIL RAILING

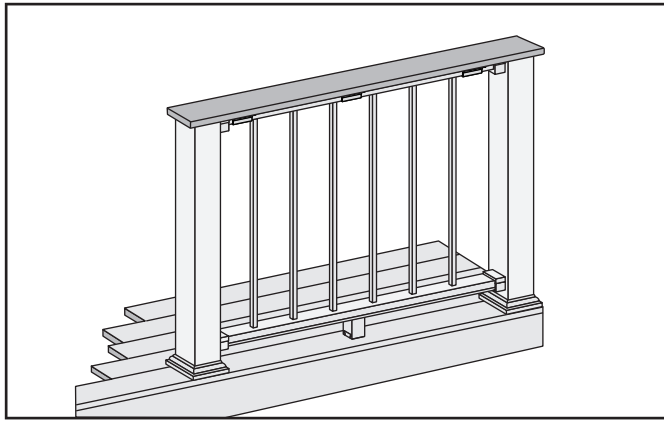

IMPORTANT NOTE:

» **ONLY** for use with pressure-treated 4 x 4 post (3.5" nominal square) and 4" x 4" (102 mm x 102 mm) post sleeve. Trex Signature posts, Trex post mounts or joist mount posts cannot be used with Trex Signature Cocktail railing. Cutting post and post sleeve only apply to the Cocktail style railing.

1. Installing Pressure-Treated Posts, Post Sleeves, and Skirts to Use with Trex Signature Railing

See instructions on page 81.

Cutting Post and Post Sleeve

2. Mark and cut post and post sleeve measuring from deck surface:
 - » 36-1/32" (915 mm) for 36" (914 mm) height.
 - » 42-1/32" (1068 mm) for 42" (1067 mm) height.

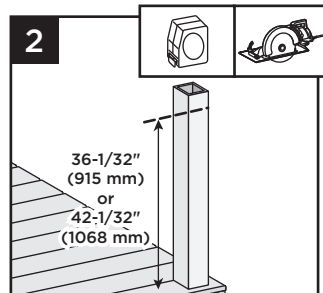

3. Installing Horizontal Fixed Brackets

See instructions on page 84.

4. Installing Horizontal Swivel Brackets

See instructions on page 101.

5. Cutting Railings for Horizontal Fixed Brackets

See instructions on page 87 - Post-to-Post, page 91 - Post-to-Crossover Post, or page 95 - Crossover Post-to-Crossover Post.

6. Cutting Railings for Horizontal Swivel Brackets

See instructions on page 102.

7. Attaching Center Baluster to Bottom Rail

See instructions on page 88 - Post-to-Post, page 92 - Post-to-Crossover Post, or page 96 - Crossover Post-to-Crossover Post.

8. Attaching Foot Block (when required)

See instructions on page 89.

9. Attaching Bottom Rail Cover and Bottom Rail to Brackets

See instructions on page 88 - Post-to-Post, page 92 - Post-to-Crossover Post, or page 96 - Crossover Post-to-Crossover Post.

10. Installing Remaining Balusters into Bottom Rail

See instructions on page 89 - Post-to-Post, page 93 - Post-to-Crossover Post, or page 97 - Crossover Post-to-Crossover Post.

11. Attaching Top Rail and Top Rail Cover

See instructions on page 90 - Post-to-Post, page 93 - Post-to-Crossover Post, or page 97 - Crossover Post to-Crossover Post.

NOTE: Top Bracket Covers are not attached in this configuration.

12. Attaching Deck Board to Top Rail

Place deck boards (**DO NOT** use Enhance deck boards for top rail) over top rails. Attach boards on each post with Trex-recommended composite screws (quantity of 2 per each board end).

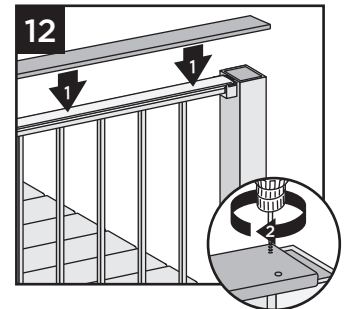

13. Secure boards to top rail using Trex Signature Cocktail Bracket (sold separately). Ensure that there is a bracket at each end of the railing section, then space brackets approximately every 24" and attach with 4 screws provided.

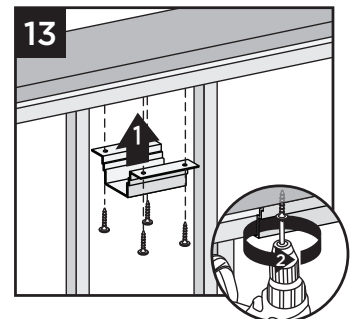

NOTE: Pre-drilling before attachment is recommended.



HOW TO INSTALL TREX SIGNATURE® COCKTAIL RAILING/CONTINUED

14. Use scarf cut for posts where two deck boards meet.

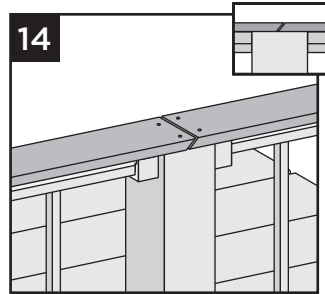

NOTES:

- » Leave 1/8" (3 mm) gap between deck boards.
- » Deck boards can overhang end of last post maximum 1/2" (13 mm).

15. **Attachment of Bottom Bracket Covers and Skirts**

See instructions on page 90.

HOW TO INSTALL TREX SIGNATURE® TRADITIONAL RAILING

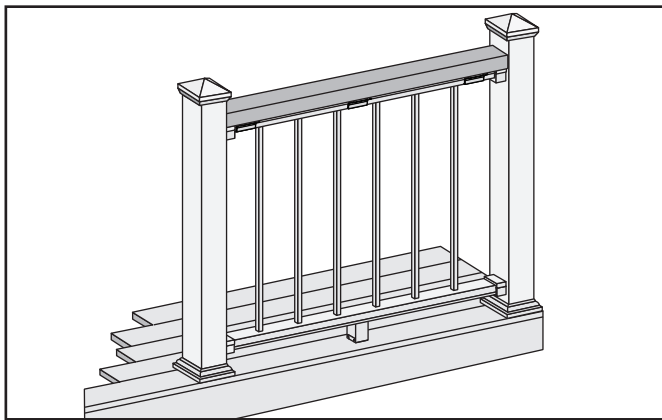

Important: Only use for use with pressure-treated 4 x 4 post (3.5" nominal square), Trex Post Mounts or Joist Mount Posts and 4" x 4" (102 mm x 102 mm) or 6" x 6" post sleeve. Trex Signature Posts and Joist Mount Posts cannot be used with Trex Signature Traditional railing.

1. **Installing Pressure-Treated Posts, Post Sleeves, and Skirts to Use with Trex Signature Railing**
See instructions on page 81.
2. **Installing Horizontal Fixed Brackets**
See instructions on page 84.
3. **Installing Horizontal Swivel Brackets**
See instructions on page 101.
4. **Cutting Railings for Horizontal Fixed Brackets**
See instructions on page 87 - Post-to-Post, page 91 - Post-to-Crossover Post, or page 95 - Crossover Post-to-Crossover Post.
5. **Cutting Railings for Horizontal Swivel Brackets**
See instructions on page 102.

6. **Attaching Center Baluster to Bottom Rail**

See instructions on page 88 - Post-to-Post, page 92 - Post-to-Crossover Post, or page 96 - Crossover Post-to-Crossover Post.

7. **Attaching Foot Block (when required)**

See instructions on page 89.

8. **Attaching Bottom Rail Cover and Bottom Rail to Brackets**

See instructions on page 88 - Post-to-Post, page 92 - Post-to-Crossover Post, or page 96 - Crossover Post-to-Crossover Post.

9. **Installing Remaining Balusters into Bottom Rail**

See instructions on page 89 - Post-to-Post, page 93 - Post-to-Crossover Post, or page 97 - Crossover Post-to-Crossover Post.

10. **Attaching Top Rail and Top Rail Cover**

See instructions on page 90 - Post-to-Post, page 93 - Post-to-Crossover Post, or page 97 - Crossover Post-to-Crossover Post.

NOTE: Top Bracket Covers are not attached in this configuration.

11. **Attaching 2 x 4 to Top Rail**

Measure between posts and cut 2 x 4 to length.

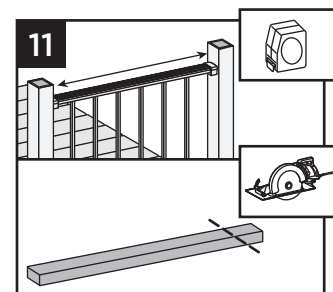

HOW TO INSTALL TREX SIGNATURE® TRADITIONAL RAILING/CONTINUED

12. Place 2 x 4 on Trex Signature top rail.

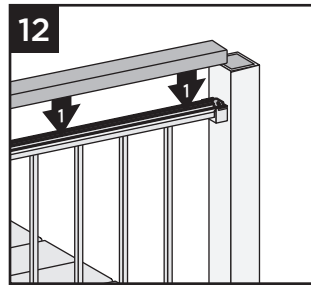

14. Pre-drill and toenail 2-1/2" (6.4 cm) approved deck screw at each end of 2 x 4 into post on back side of rail (side not facing decking).

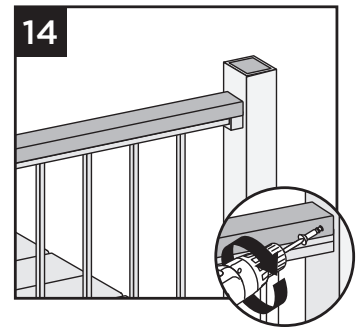

13. Secure 2 x 4 (to top rail using Trex Signature Cocktail Bracket (sold separately). Ensure that there is a bracket at each end of the railing section, then space brackets approximately every 24" and attach with 4 screws provided.

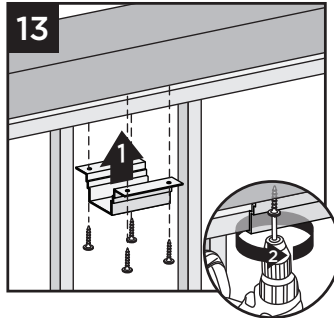

15. **Attachment of Bottom Rail Bracket Covers and Caps**

See instructions on page 90.

NOTE: *Pre-drilling before attachment is recommended.*

HOW TO INSTALL HORIZONTAL SWIVEL BRACKETS

TREX SIGNATURE® STANDARD

Attach Swivel Brackets Base Using Trex Signature Posts

TIP: Use a clamp to help hold brackets in place while fastening with screws.

1. Measure 1-3/8" (3.5 cm) from top of post base plate or 1-7/8" (4.8 cm) from decking surface. Mark with light line.

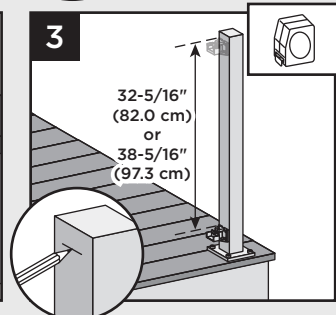
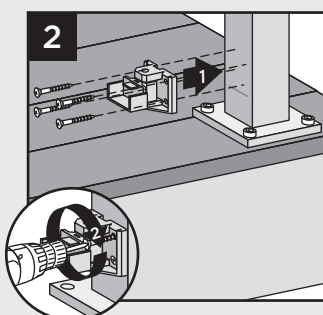
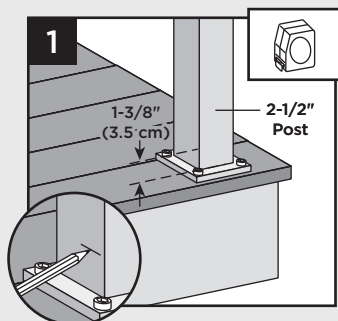

2. Center lower bracket on post **above** the marked line and attach using four self-tapping screws (*provided*).
3. Measure up 32-5/16" (82.0 cm) for 36" (91.4 cm) tall railing or 38-5/16" (97.3 cm) for 42" (106.7 cm) tall railing from top of lower rail bracket. Mark with a light line.
4. Center upper bracket on post **below** marked line and attach using four self-tapping screws (*provided*).

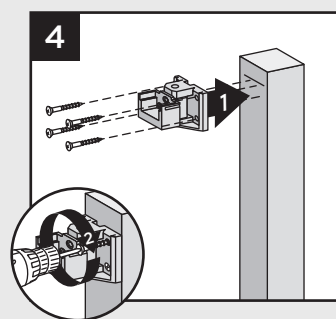

NOTE: Upper bracket is not required on crossover post configuration.

Attach Swivel Brackets Using Pressure-treated Posts and Post Sleeves

TIP: Use a clamp to help hold brackets in place while fastening with screws.

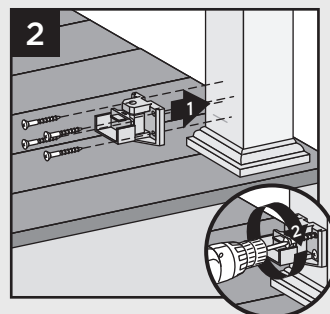
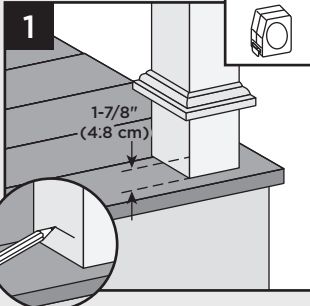

1. Measure 1-7/8" (4.8 cm) up from deck surface to bottom of bracket. Slide skirt up to allow for proper measurement, then push skirt back down onto surface of decking **BEFORE ATTACHING BRACKET**. Mark with light line.
2. Center lower bracket on post **above** the marked line and attach using four 2" (5.1 cm) wood screws (*provided*).

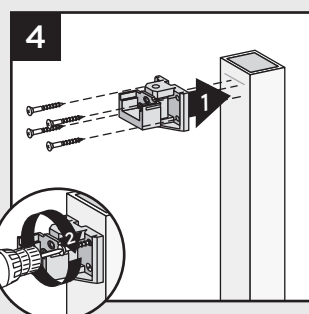
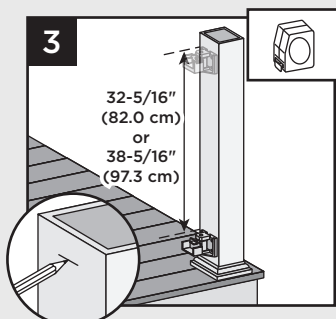

3. Measure up 32-5/16" (82.0 cm) for 36" (91.4 cm) tall railing or 38-5/16" (97.3 cm) for 42" (106.7 cm) tall railing from top of lower rail bracket. Mark with a light line.
4. Center upper bracket on post **below** marked line and attach using four 2" (5.1 cm) wood screws (*provided*).

HOW TO INSTALL HORIZONTAL SWIVEL RAILING

TREX SIGNATURE® STANDARD

NOTES:

- » WHEN USING TREX SIGNATURE HORIZONTAL SWIVEL BRACKETS, BOTH BOTTOM AND TOP RAILS WILL NEED TO BE MEASURED AND CUT TO APPROPRIATE LENGTHS.
- » HORIZONTAL SWIVEL BRACKETS CAN BE USED UP TO A 50° ANGLE FOR TREX SIGNATURE RAILINGS.
- » WHEN USING HORIZONTAL SWIVEL BRACKETS VERY IMPORTANT TO LAY OUT LOCATION AND ORIENTATION OF POSTS AND SWIVEL BRACKETS BEFORE INSTALLING SWIVEL BRACKETS.
- » WHEN RAILINGS ARE CUT TO ODD SPANS, ALL SPANS GREATER THAN 5' (1.52 M) (EXAMPLE: 8' (2.44 M) SPAN CUT INTO ONE 5' (1.52 M) SPAN AND ONE 3' (0.91 M) SPAN) WOULD REQUIRE FOOT BLOCK UNDER 5' (1.52 M) SPAN SINCE SMALLER FIXED BALUSTER IS NO LONGER CENTERED.

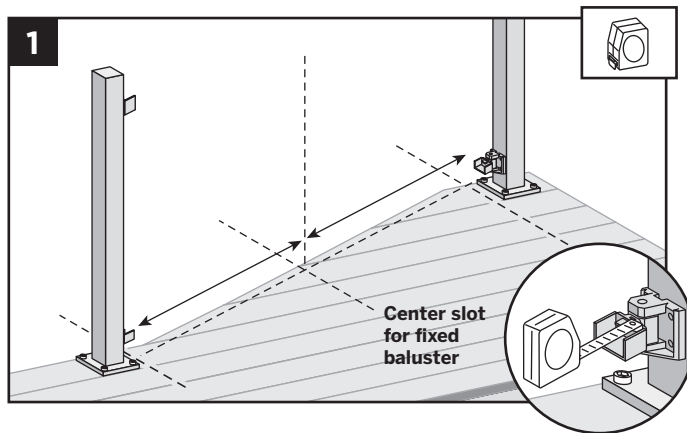

How to Measure and Cut Bottom and Top Railings

1. With brackets in correct swivel location, measure distance from inside of bracket to inside of bracket. ENSURE THAT BEFORE CUTTING, BALUSTERS HOLES ON BOTH BOTTOM AND TOP RAIL LINE UP. ALSO MAKE SURE CENTER BALUSTER SLOT IS AS CLOSE TO THE MIDDLE OF THE SPAN AS POSSIBLE. In some cases, due to odd railing spans, the center baluster may need to be offset in one or the other direction to ensure there is enough room at both post locations for balusters to be placed.

Cutting Bottom Rail and Bottom Rail Cover

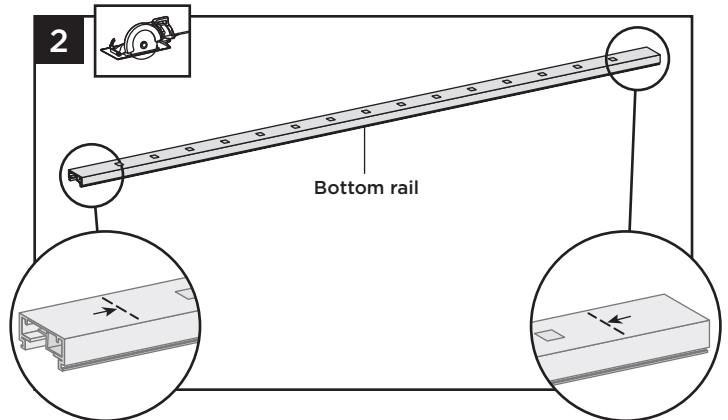

2. Cut bottom rail to the measurement between the bottom swivel brackets.

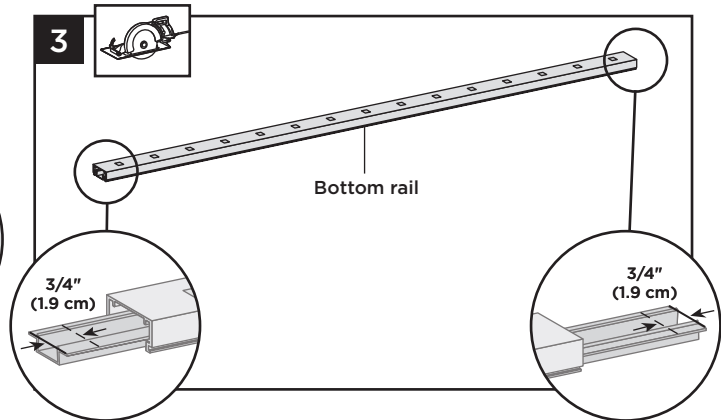

3. Slide rail insert out and cut 3/4" (1.9 cm) FROM EACH SIDE of insert, then slide back inside rail and center.

4. Mark and cut bottom rail cover 1-1/2" (3.8 cm) shorter than bottom rail.

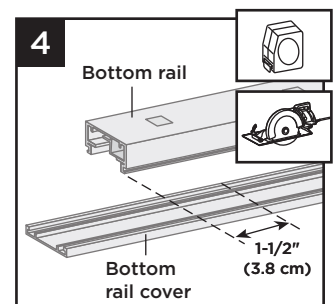

HOW TO INSTALL HORIZONTAL SWIVEL RAILING/CONTINUED

TREX SIGNATURE® STANDARD

Cutting Top Rail

Option 1:

For Post-to-Post Configuration

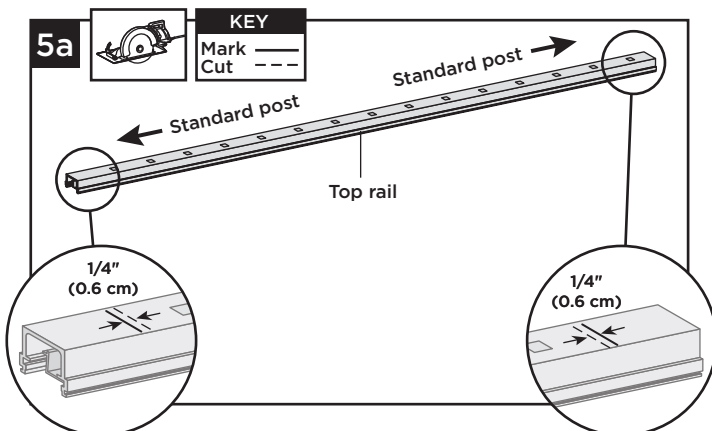

5a. Cut top rail to the measurement between the top swivel brackets. For standard post-to-standard post configurations this would be same dimensions as that of the bottom rail.

Cutting Top Rail

Option 2:

For Post-to-Crossover Post Configuration

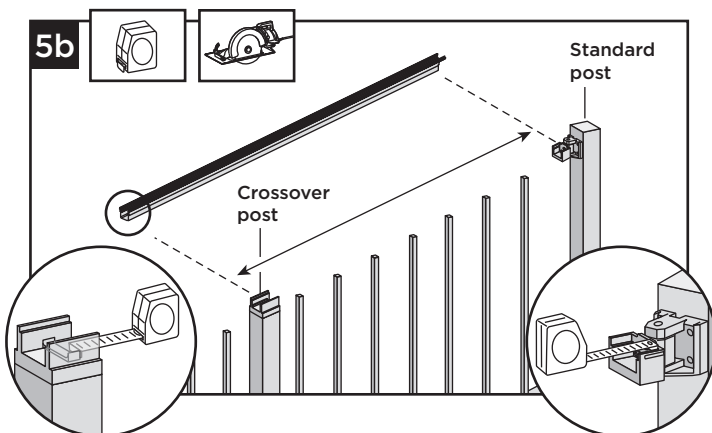

5b. When going from standard-post to crossover post, measurement must be taken from inside of top horizontal swivel bracket to inside lip of crossover post (which is attached to top of crossover post).

Cutting Top Rail Insert and Cover

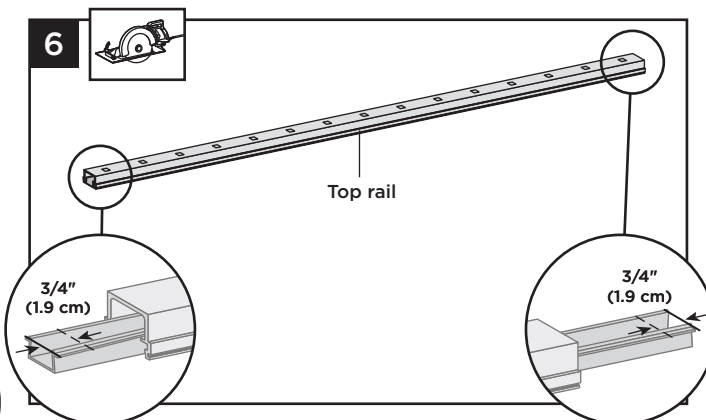

6. Slide rail insert out and cut 3/4" (1.9 cm) FROM EACH SIDE of insert, then slide back inside rail and center.

7. Mark and cut top rail cover same length as top rail for all top rail configurations.

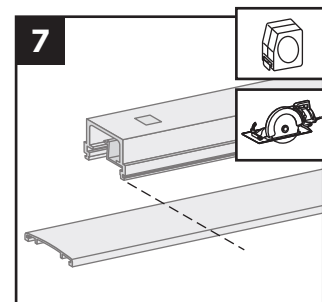

8. Attaching Center Baluster to Bottom Rail

See instructions on page 88 Post-to-Post or 92 Post-to-Crossover Post.

9. Attaching Foot Block (when required)

See instructions on page 89.

10. Attaching Bottom Rail Cover and Bottom Rail to Brackets

See instructions on page 89 Post-to-Post or 92 Post-to-Crossover Post.

11. Installing Remaining Balusters into Bottom Rail

See instructions on page 89 Post-to-Post or 93 Post-to-Crossover Post.

12. Attach Upper Railings

See instructions on page 90 Post-to-Post or 93 Post-to-Crossover Post.

13. Attachment of Bracket Covers, Skirts, and Caps

See instructions on page 90 Post-to-Post or 94 Post-to-Crossover Post.

TREX SIGNATURE® STAIR RAILING

BRACKET HARDWARE (INCLUDING STAIR SWIVEL BRACKETS, STAIR CROSSOVER BRACKET, AND COMPOUND SWIVEL BRACKETS) TREX SIGNATURE

FIXED BRACKET - STAIR HARDWARE

- AA. Bottom Stair Bracket and Cover - Lower Rail
- BB. Top Stair Bracket and Cover - Lower Rail
- CC. Fastener Pack
- DD. Bottom Stair Bracket and Cover - Upper Rail
- EE. Top Stair Bracket and Cover - Upper Rail

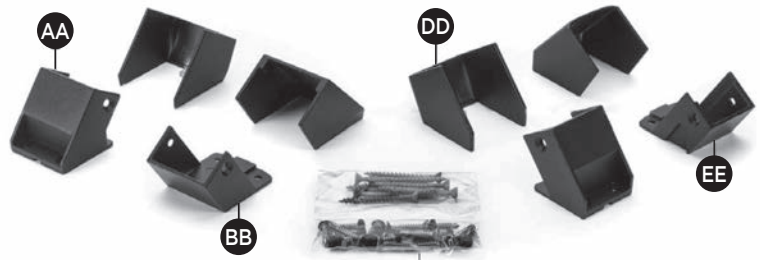

SWIVEL BRACKET - STAIR HARDWARE

- FF. Swivel Top Rail Bracket and Cover - Stair
- GG. Swivel Bottom Rail Bracket and Cover - Stair
- HH. Fastener Covers
- II. Fastener Pack

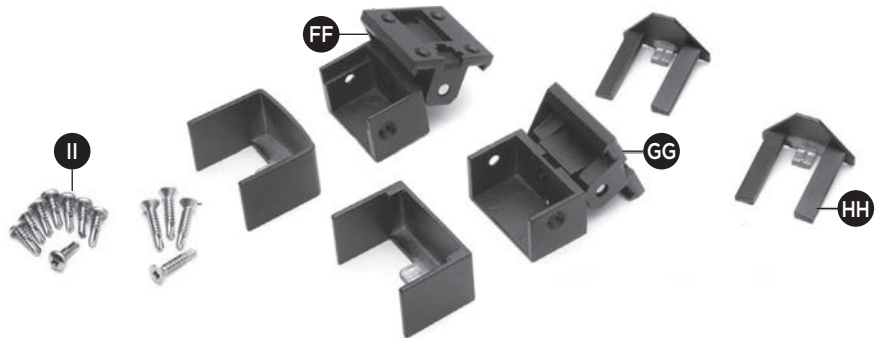

COMPOUND SWIVEL BRACKET - STAIR HARDWARE

- JJ. Compound Swivel Top Rail Bracket and Cover - Stair
- KK. Compound Swivel Bottom Rail Bracket and Cover - Stair
- LL. Fastener Covers
- MM. Fastener Pack

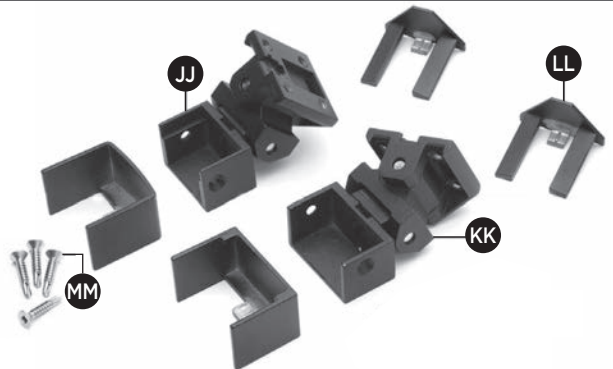

SWIVEL CROSSOVER BRACKET KIT - STAIR HARDWARE

- NN. Swivel Crossover Bracket - Stair
- OO. Post-to-Bracket Fasteners

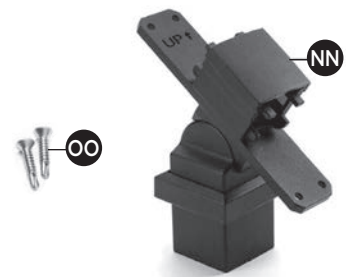

HOW TO INSTALL STAIR POSTS AND STAIR RAILING

TREX SIGNATURE®

IMPORTANT NOTES:

- » FOR A 6' OR 8' STAIR RAIL, POST TO POST SPAN WILL BE LESS THAN 6' OR 8'. PRIOR TO INSTALLING STAIR POSTS CALCULATE POST TO POST SPAN USING A MAXIMUM STAIR RAIL LENGTH REQUIRED AND THE ANGLE (32°-37°) AT WHICH THE STAIR RAILS WILL BE INSTALLED. DO NOT INSTALL STAIR POSTS AT 6' OR 8' SPAN, AS STAIR RAILINGS WILL THEN BE TOO SHORT.
- » TREX SIGNATURE POSTS CANNOT BE USED WITH TREX SIGNATURE TRADITIONAL OR TREX SIGNATURE COCKTAIL STAIR DESIGNS, ONLY PRESSURE-TREATED POST/POST SLEEVES CAN BE USED. REFER TO DETAILED INSTRUCTIONS FOR MORE INFORMATION.
- » All Trex Signature stair installations require the use of 53" (134.6 CM) stair post, measured and cut to appropriate length if required.
- » If crossover stair post is required, use stair post (again cut to appropriate length if required) and use swivel crossover bracket.
- » Trex Signature Stair fixed brackets are designed to work only with stair slopes of 32°-37°.
- » For smaller (less than 32°) or larger angles (greater than 37°), use the Trex Signature Stair Swivel brackets.
- » Trex Signature Compound swivel stair brackets are designed for flared stair designs.
- » At all final end post configurations, top stair rail will need to be measured (making sure balusters line up vertically) and cut.
- » For odd span lengths, both bottom and top stair rails will need to be measured (making sure balusters line up vertically) and cut. Also, ensure that balusters are spaced with equal distance on each side of the post.
- » Rails that do not require cutting must be oriented in the correct direction to ensure balusters are spaced properly when installed in brackets. On both bottom and top stair railings, baluster hole closest to the end of each stair rail is to be installed at the top of the stair section. Ensure that both bottom and top rails are correct and balusters line up vertically before INSTALLING.
- » Foot blocks are required ONLY for All Clear Span Applications over 6' (1.83 m) thus these stair railing spans must be installed over the decking frame or on inside of rim joist. Signature Stair Foot blocks are sold separately.

Installing Standard Trex Signature Stair Posts, Trex Signature Stair Crossover Posts, or Pressure-treated Post, Post Sleeves and Skirts

1. Make sure 53" (135.6 cm) posts are used for all stair posts.

2. If Trex Signature stair posts are used, install at nose of stair tread directly under required blocking. See Trex Signature horizontal post instructions.

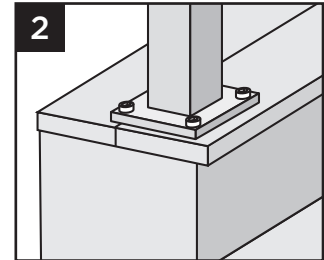

Installing Pressure-Treated Posts

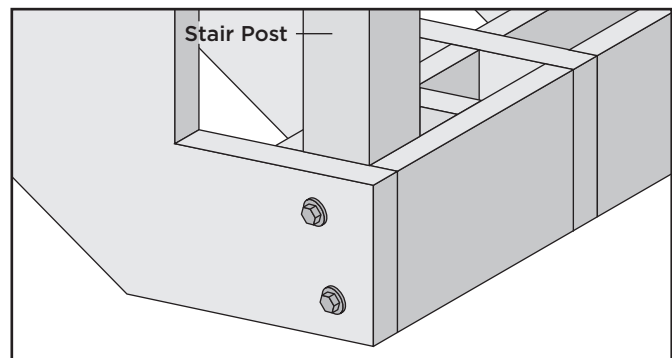

- » PLEASE REFER TO LOCAL BUILDING CODE REQUIREMENTS PRIOR TO ATTACHING PRESSURE TREATED POSTS.
- » PRESSURE TREATED POSTS MUST BE INSTALLED ON INSIDE OF STAIR STRINGER AND AT NOSE OF STAIR TREAD.
- » POST TO POST SPAN WILL BE LESS THAN 6' OR 8'. PRIOR TO INSTALLING POSTS CALCULATE POST TO POST SPAN USING A MAXIMUM RAIL LENGTH REQUIRED AND THE ANGLE (32°-37°) AT WHICH THE RAILS WILL BE INSTALLED. DO NOT INSTALL STAIR POSTS AT 6' OR 8' SPAN, AS STAIR RAILINGS WILL THEN BE TOO SHORT.
- » Attach posts using code approved hardware and also use added blocking.
- » Bolts can be countersunk flush with framing to allow for fascia attachment.
- » In most cases, a post and post sleeve longer than 39" (991 mm) will be needed on the lower section of stair rail to accommodate stair angle.

NOTE: Blocking can be added for extra strength.



ATTACHING FIXED STAIR BRACKETS AND RAILS TO POSTS AND PRESSURE-TREATED POST AND POST SLEEVES TREX SIGNATURE®

NOTES:

- » All Trex Signature fixed stair brackets work **ONLY** with stair slopes of 32°-37°.
- » Illustrations shown are representations when using Trex Signature post, but same rules apply if using pressure-treated posts and post sleeves.
- » Use a clamp to help hold stair brackets in place while fastening with screws.

IMPORTANT NOTE:

» **BEFORE ATTACHING ANY UPPER BRACKETS MAKE SURE PROPER RAILING HEIGHTS ARE ACHIEVED. RAILING HEIGHTS AND UPPER BRACKET HEIGHTS MAY NEED TO BE ADJUSTED, HOWEVER, DO NOT REDUCE HEIGHTS BASED ON YOUR RAILING CODE REQUIREMENTS. MEASURE CAREFULLY AS DIMENSION HEIGHTS MAY NEED TO BE ADJUSTED!**

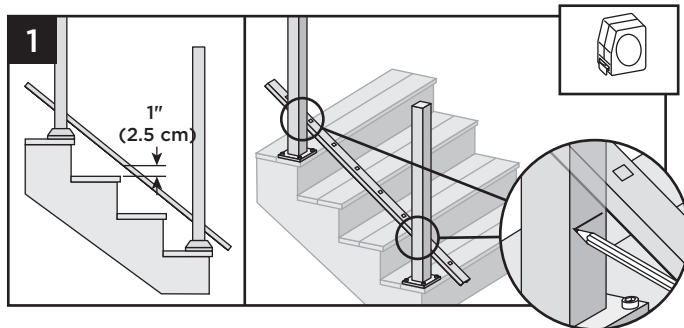

1. Lay bottom stair rail on steps beside posts. Position bottom rail at least 1" (2.5 cm) above nose of stair tread.

Tip: Use a 1" (2.5 cm) deck board as a spacer board and clamp rails to post. Mark where lower brackets are to be attached to both posts. Mark at underside of railing location.

Installing Lower Fixed Stair Brackets

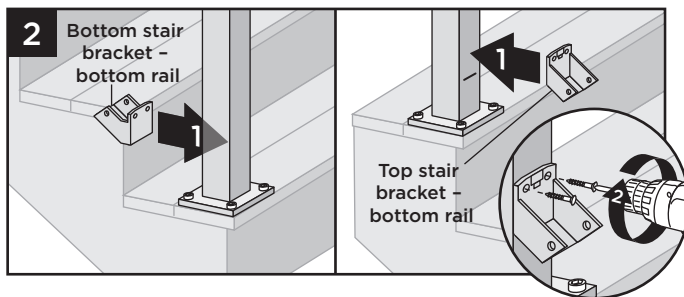

2. Center lower stair bracket on post above the marked line and attach using two self-tapping screws (provided). In some cases it may be difficult to attach the stair bracket on the lower stair post. A 90° cordless drill is recommended to attach screws in this area.

How to Measure Bottom Stair Railing (WHEN REQUIRED)

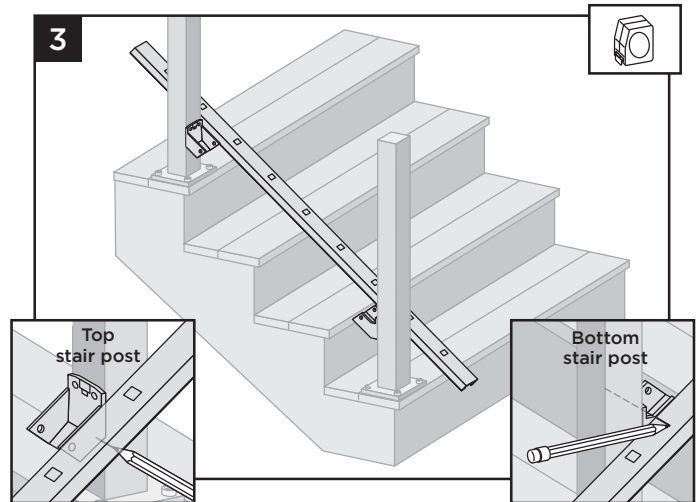

- 3 Position bottom stair rail along the nose of the stair treads. Ensure that before cutting, balusters holes are centered in between the posts and also allow for clearance for attachment to brackets. On top stair post location, mark **UNDERSIDE** of lower rail. On bottom stair post location mark **TOPSIDE** of lower rail at angled intersection of the bracket.

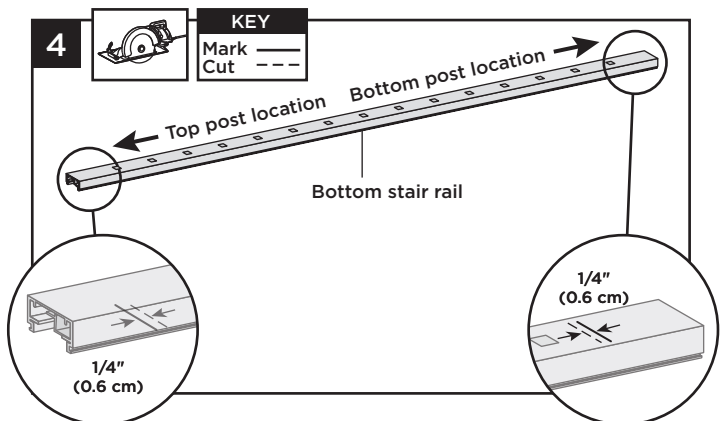

4. Cut each end of the bottom stair rail, rail insert, and bottom rail cover 1/4" (0.6 cm) shorter than the mark on each end to allow for fit into bottom stair rail brackets.

NOTE: Railing does not need to be cut at angle. Brackets are designed to allow for railing to be installed with standard straight cut.

ATTACHING FIXED STAIR BRACKETS AND RAILS TO POSTS AND PRESSURE-TREATED POST AND POST SLEEVES/CONTINUED

TREX SIGNATURE®

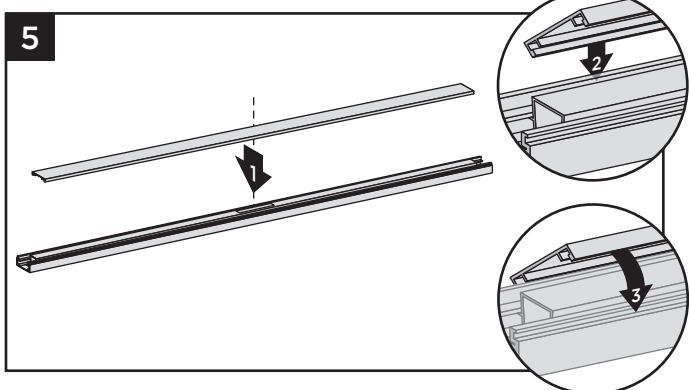

5. Attach “flat” bottom stair rail cover to bottom stair rail. Align cover on one side of the bottom rail in slot on side of rail. Then starting from one end of rail snap cover onto opposing slot working down the length of the rail. In some cases, **GENTLE** tapping with a **rubber mallet** may facilitate fastening.

Attaching Foot Block (when required)

Required **ONLY** for All Clear Span Applications over 6' (1.83 m) when shorter fixed baluster is fully centered, or unsupported spans greater than 5' (1.52 m) (example: 8' (2.44 m) span cut into one 5' (1.52 m) span and one 3' (0.91 m) span would require foot block under 5' (1.52 m) span since shorter fixed baluster is no longer centered). **NOTE THAT FOOT BLOCK IS SOLD SEPARATELY.**

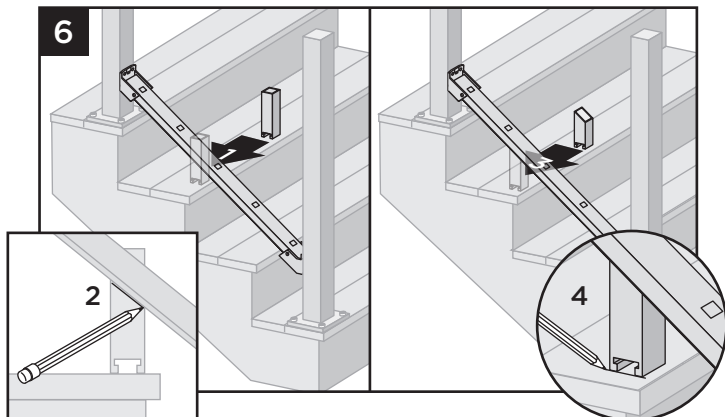

6. Temporarily set bottom rail in bottom brackets, and place foot block towards the nose of the stair tread along the side of the bottom rail. Mark location of angle on foot block and cut on mark. Then place foot block under the center of the bottom rail. Mark placement location of the base. Remove lower rail.

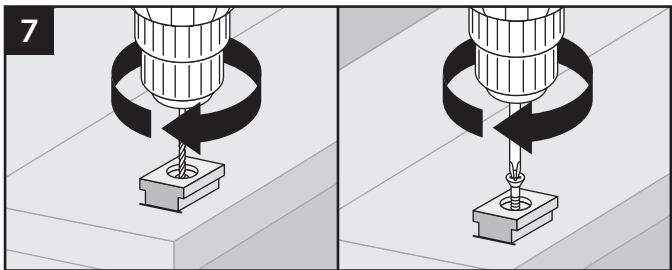

7. Place base (smaller side facing down) on decking surface. Pre-drill using a 3/16" bit. Attach base of foot block using one screw at an angle through base and into decking.

8. After attached, use a **rubber mallet** along with **scrap piece of wood** to tap foot block until it locks into place.

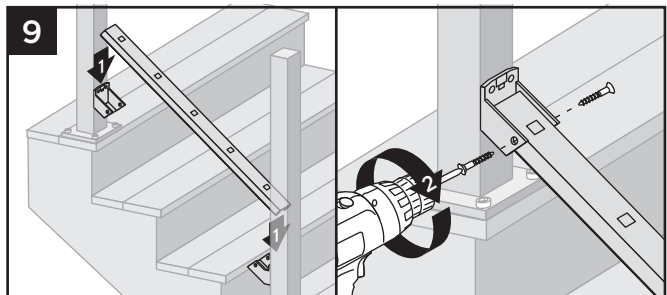
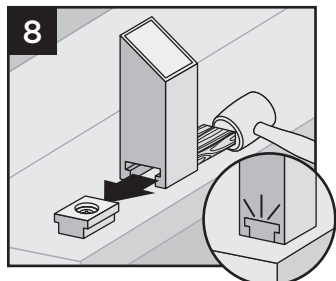

9. Set bottom stair rail into bottom stair rail brackets. Attach bottom stair rail to bottom stair bracket using two self-tapping screws (*provided*) on each side of bracket.

Installing Upper Fixed Stair Brackets and Measuring Upper Rail

IMPORTANT NOTE: BEFORE CUTTING ANY TOP RAILS, MAKE SURE THAT ALL BALUSTER HOLES LINE UP PARALLEL WHEN MEASURING!

10. Place two balusters into lower rail at each end closest to post.

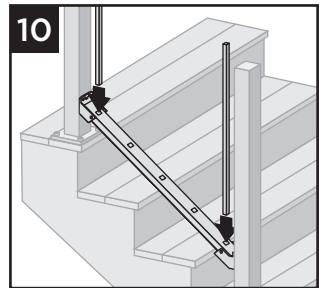

ATTACHING FIXED STAIR BRACKETS AND RAILS TO POSTS AND PRESSURE-TREATED POST AND POST SLEEVES/CONTINUED

TREX SIGNATURE®

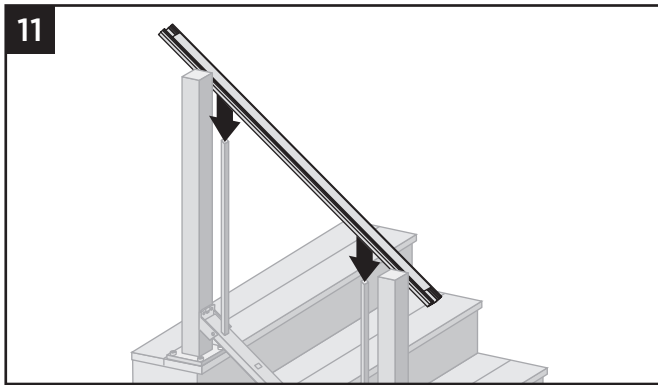

11. Position top stair rail onto balusters ensuring balusters are fully seated in top rail (position to side of post) and **ENSURE** that balusters are parallel with post.

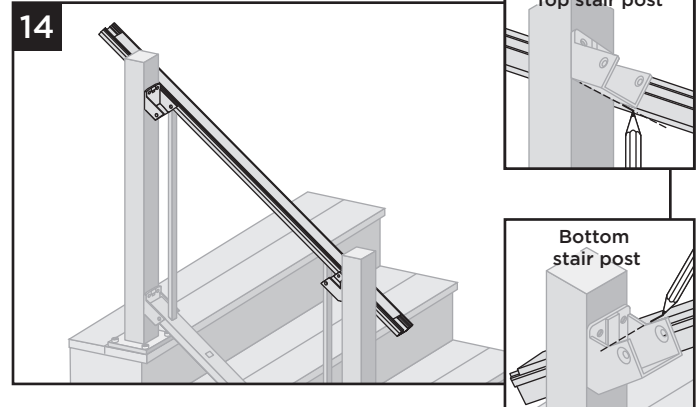

14. On top stair post location, mark **UNDERSIDE** of upper rail. On bottom stair post location mark **TOPSIDE** of upper rail at angled intersection inside the bracket.

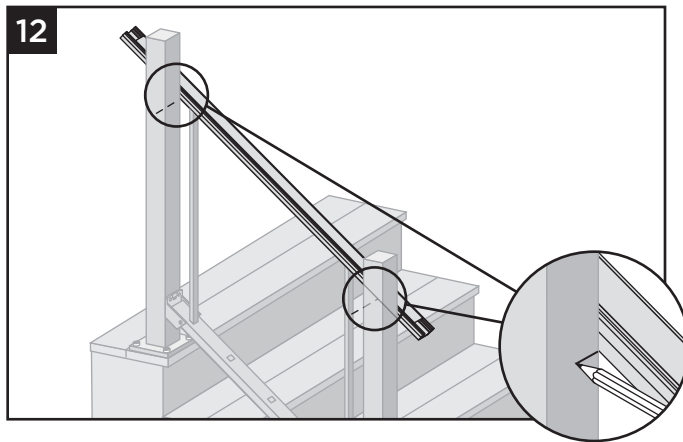

12. Mark a light line on posts at **UNDERSIDE** of rail to show the location of the fixed stair brackets.

Cutting Top Stair Rail Cover, and Attachment of Top Stair Rail Cover

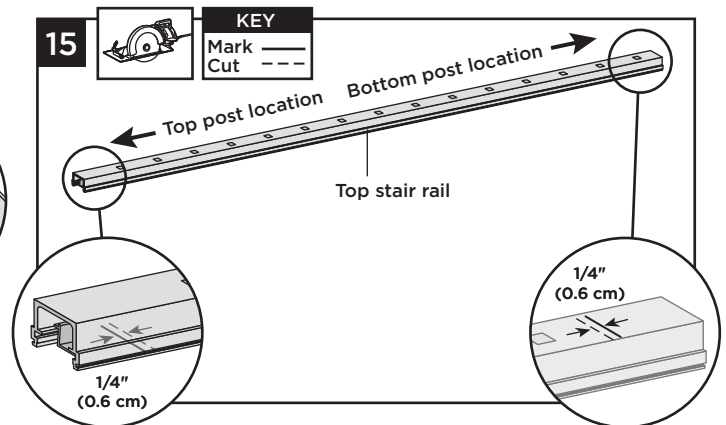

15. Cut each end of top stair rail along with rail insert 1/4" (0.6 cm) shorter than mark to allow for fit into top stair rail bracket.

NOTE: Railing does not need to be cut at angle. Brackets are designed to allow for railing to be installed with standard straight cut.

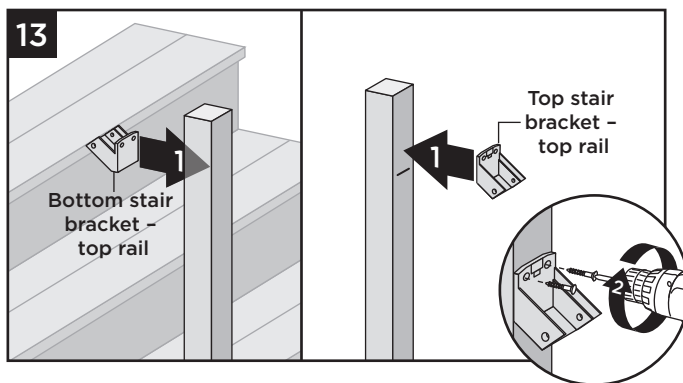

13. Remove upper stair rail and center upper stair fixed bracket on post **above** the marked line and attach using two self-tapping screws (*provided*).

16. Mark and cut top rail cover same length as top rail for all top rail configurations.

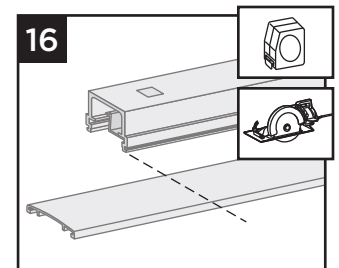

ATTACHING FIXED STAIR BRACKETS AND RAILS TO POSTS AND PRESSURE-TREATED POST AND POST SLEEVES/CONTINUED

TREX SIGNATURE®

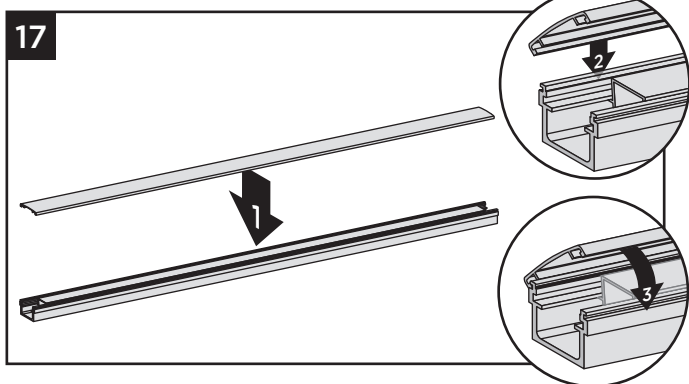

17. Attach “crowned” upper stair rail cover to upper stair rail by aligning cover on one side of rail. Then starting from one end of stair rail, snap cover onto opposing slot working down length of stair rail. **GENTLE** tapping with a **rubber mallet** may facilitate the fastening.

Installing Balusters into Bottom Stair Rail

18. Place balusters into holes in lower stair rail by snapping fully into place. In some cases, **GENTLE** tapping with a **rubber mallet** may facilitate fastening.

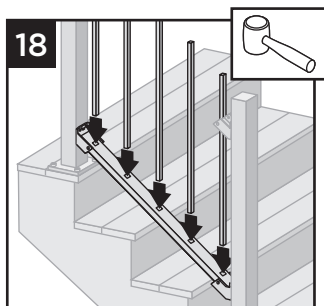

Attaching Upper Stair Rails

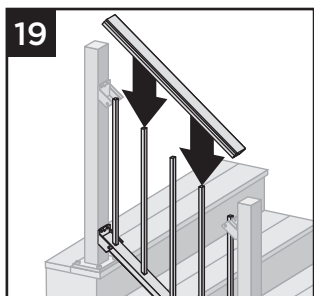

19. Working from one end of upper stair rail, snap balusters into upper stair rail working down length of rail.

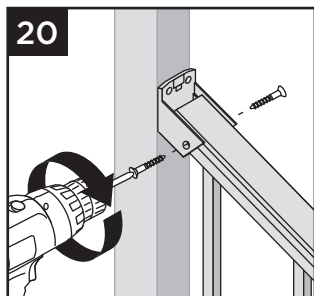

20. Attach top stair rail to top stair bracket (all types) using two self-tapping screws (*provided*) on each side of stair bracket.

NOTE: Pre-drilling is required (7/64" [0.28 cm] drill bit) for attachment of stair railing to stair bracket.

Attachment of Stair Bracket Covers, Skirts, and Caps

21. Attach corresponding bracket covers over opening in upper and bottom rails.

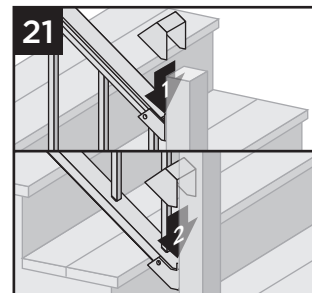

22. Attach provided post skirt to bottom of posts when using Trex Signature posts.

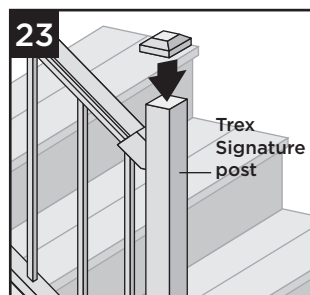
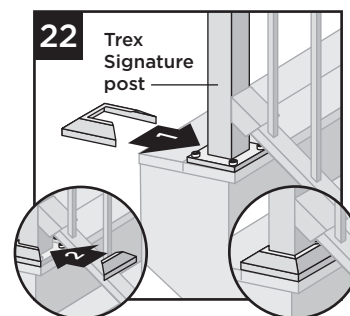

23. Attach post caps to Trex Signature posts (use of **rubber mallet** may be required for secure attachment).

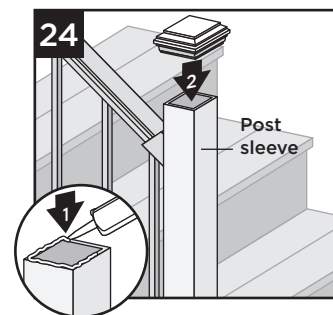

24. Attach post caps to post sleeves using external grade PVC construction adhesive (apply adhesive on the inside self-centering/corner tabs).

ATTACHING STAIR SWIVEL/COMPOUND SWIVEL BRACKETS AND RAILS TO POSTS AND PRESSURE-TREATED POST AND POST SLEEVES

TREX SIGNATURE®

NOTES:

- » Illustrations shown are representations when using Trex Signature posts, but same rules apply if using pressure-treated posts and post sleeves.
- » Use a clamp to help hold stair brackets in place while fastening with screws.

IMPORTANT NOTE:

- » BEFORE ATTACHING ANY UPPER BRACKETS, MAKE SURE PROPER RAILING HEIGHTS ARE ACHIEVED. RAILING HEIGHTS AND UPPER BRACKET HEIGHTS MAY NEED TO BE ADJUSTED, HOWEVER, DO NOT REDUCE HEIGHTS BASED ON YOUR RAILING CODE REQUIREMENTS. MEASURE CAREFULLY AS DIMENSION HEIGHTS MAY NEED TO BE ADJUSTED!

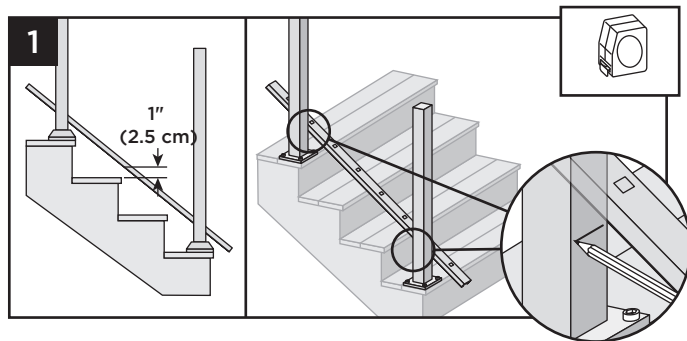

1. Lay bottom stair rail on steps beside posts. Position bottom rail at least 1" (2.5 cm) above nose of stair tread.

Tip: Use a 1" (2.5 cm) deck board as a spacer board and clamp rails to post. Mark where lower brackets are to be attached to both posts. Mark at underside of railing location.

Installing Lower Stair Swivel and Compound Swivel Brackets

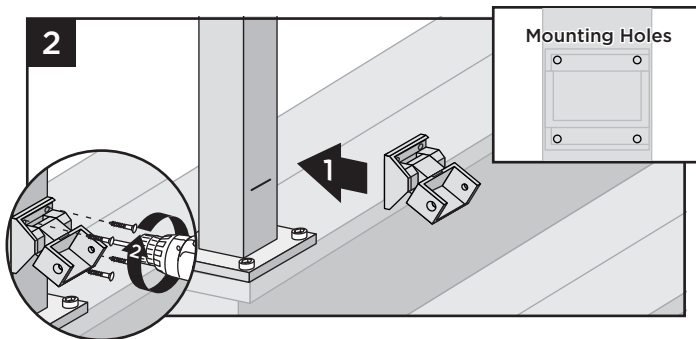

2. Center lower stair swivel bracket on post above the marked line and attach using four self-tapping screws (provided). In some cases it may be difficult to attach the stair bracket on the lower stair post. A 90° cordless drill is recommended to attach screws in this area.

How to Measure Bottom Stair Railings (WHEN REQUIRED)

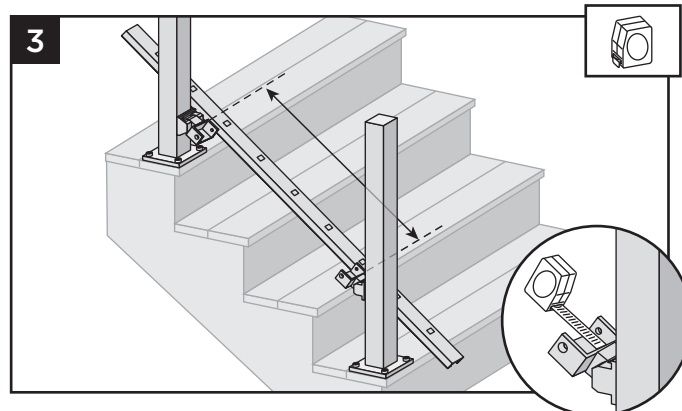

3. With brackets in correct swivel locations, measure distance from inside of swivel bracket to inside of swivel bracket. Ensure that before cutting, balusters holes are parallel and centered in between the posts and also allow for clearance for attachment to brackets. Mark bottom stair rail at each intersection.

Cutting Bottom Stair Rail, Bottom Stair Rail Cover, and Attachment of Bottom Stair Rail Cover

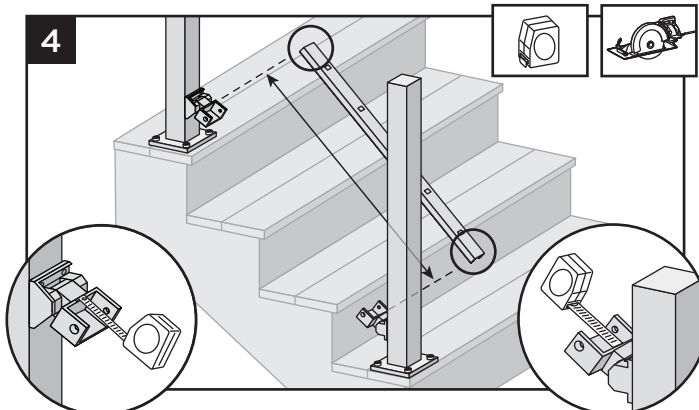

4. Cut each end of the bottom rail, rail insert, and bottom rail cover at the mark on each end to allow for fit into bottom stair rail brackets.

NOTE: Railing does not need to be cut at angle. Brackets are designed to allow for railing to be installed with standard straight cut.



ATTACHING STAIR SWIVEL/COMPOUND SWIVEL BRACKETS AND RAILS TO POSTS AND PRESSURE-TREATED POST AND POST SLEEVES/CONTINUED

TREX SIGNATURE®

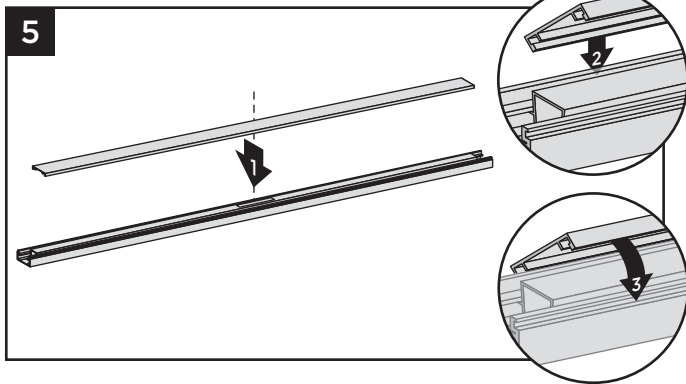

5. Attach “flat” bottom stair rail cover to bottom stair rail. Align cover on one side of the bottom rail in slot on side of rail. Then starting from one end of rail snap cover onto opposing slot working down the length of the rail. In some cases, **GENTLE** tapping with a **rubber mallet** may facilitate fastening.

6. **Attaching Foot Block (when required)**
See instructions on page 107.

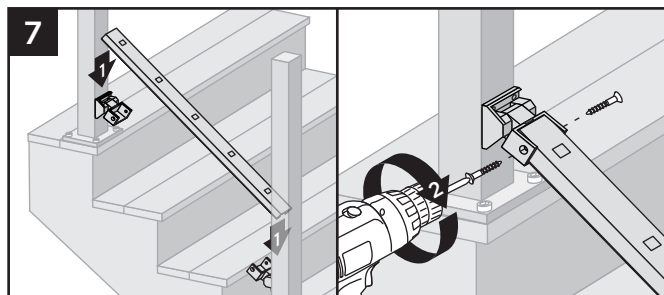

7. Set bottom stair rail into bottom stair rail brackets. Attach bottom stair rail to bottom stair bracket using two self-tapping screws (*provided*) on each side of bracket.

Installing Upper Brackets and Measuring Upper Stair Rail—Stair Swivel and Compound Swivel

IMPORTANT NOTE: BEFORE CUTTING ANY TOP RAILS MAKE SURE THAT WHEN MEASURING, ALL BALUSTER HOLES LINE UP PARALLEL!

8. Place two balusters into lower rail at each end closest to post.

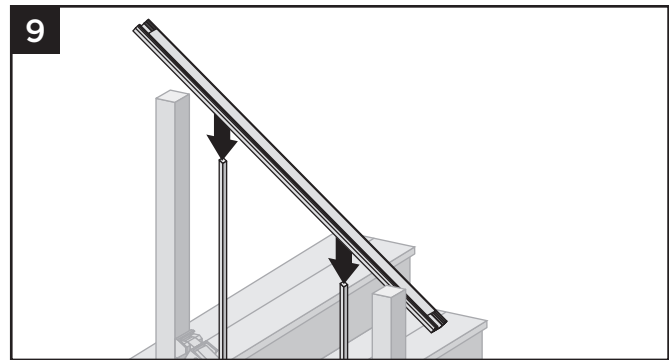
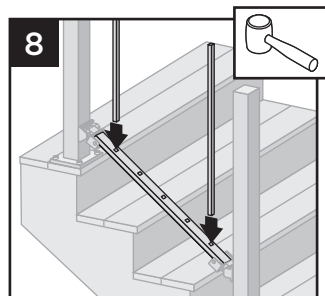

9. Position top stair rail onto balusters ensuring balusters are fully seated in top rail (position to side of post) and **ENSURE** that balusters are parallel with post.

Installing Upper Stair Swivel and Compound Swivel Brackets

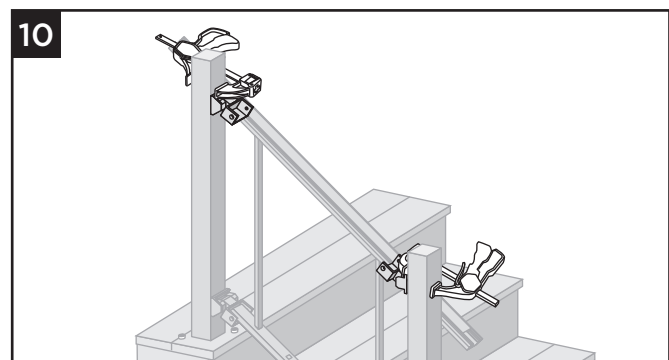

10. Clamp brackets to side of rail with brackets in correct swivel location/angle (this is important to ensure correct location of swivel brackets).

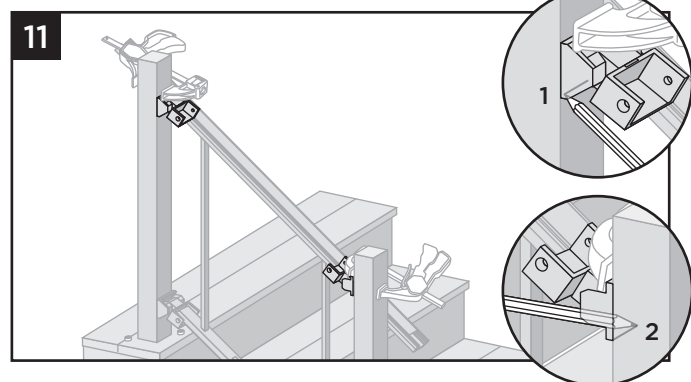

11. Mark a light line on posts at **UNDERSIDE** of where swivel bases (positioned correctly) meets the posts.

ATTACHING STAIR SWIVEL/COMPOUND SWIVEL BRACKETS AND RAILS TO POSTS AND PRESSURE-TREATED POST AND POST SLEEVES/CONTINUED

TREX SIGNATURE®

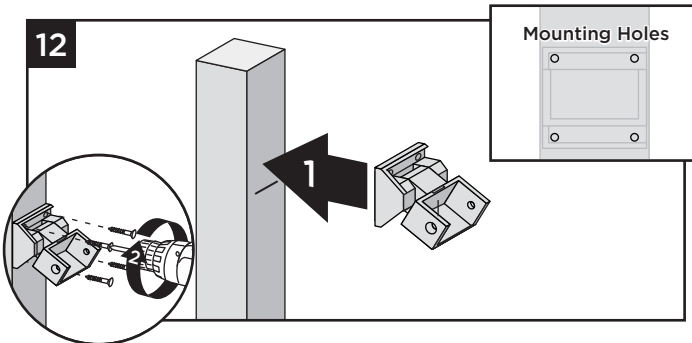

12. Remove upper stair rail from balusters and center upper stair swivel bracket on post **above** the marked line and attach using four self-tapping screws (*provided*).

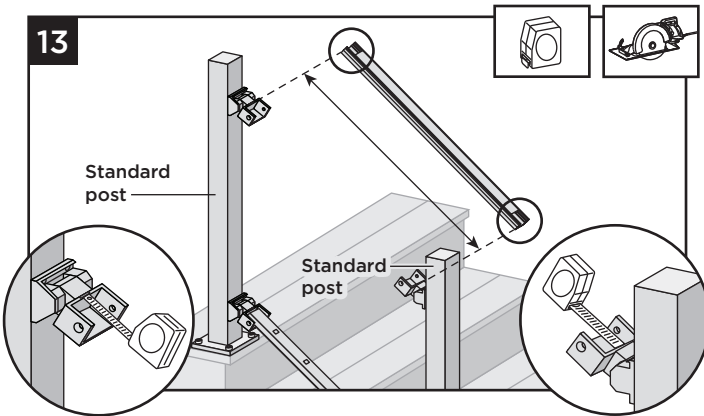

13. Cut top rail along with rail insert to the measurement between the top stair swivel brackets. For standard post to standard post configurations this would be same dimensions as that of the bottom stair rail.

14. Mark and cut top rail cover same length as top rail for all top rail configurations.

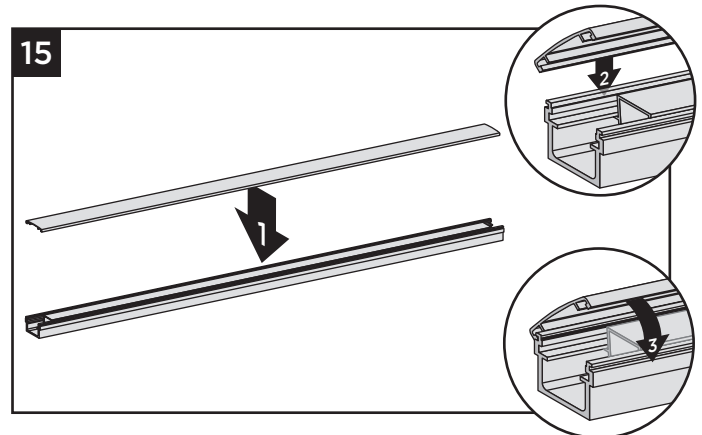
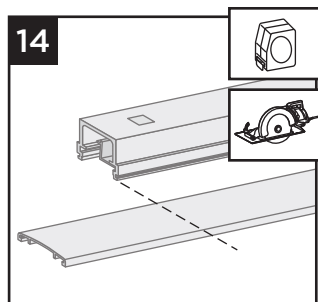

15. Attach “crowned” upper stair rail cover to upper stair rail by aligning cover on one side of rail. Then starting from one end of stair rail, snap cover onto opposing slot working down length of stair rail. **GENTLE** tapping with a **rubber mallet** may facilitate fastening.

Installing Balusters into Bottom Stair Rail

16. Place balusters into holes in lower stair rail by snapping fully into place. In some cases, **GENTLE** tapping with a **rubber mallet** may facilitate fastening.

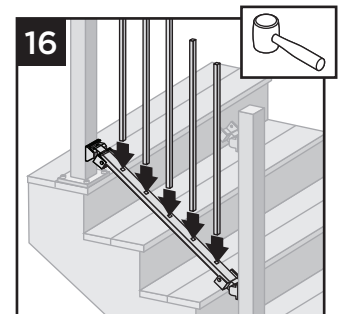

Attaching Upper Stair Rails

17. Working from one end of upper stair rail, snap balusters into upper stair rail working down length of rail.

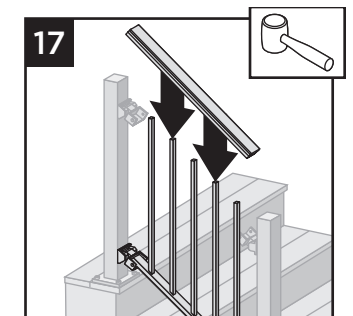

18. Attach top stair rail to top stair bracket (all types) using two self-tapping screws (*provided*) on each side of stair bracket.

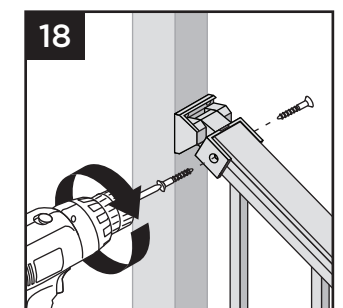

NOTE: Pre-drilling is required (7/64" [0.28 cm] drill bit) for attachment of stair railing to stair bracket.



ATTACHING STAIR SWIVEL/COMPOUND SWIVEL BRACKETS AND RAILS TO POSTS AND PRESSURE-TREATED POST AND POST SLEEVES/CONTINUED

TREX SIGNATURE®

Attachment of Stair Bracket Covers, Skirts, and Caps

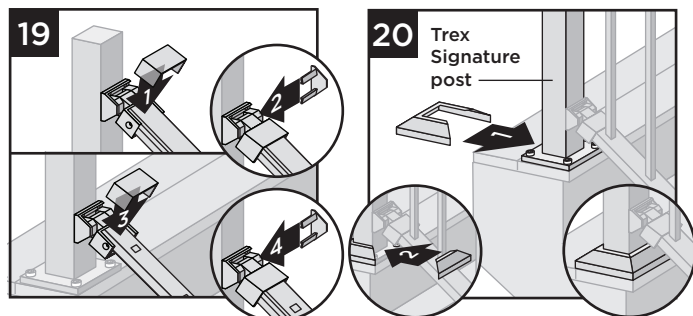

19. Attach corresponding bracket covers over opening in upper and bottom rails.
20. Attach provided post skirt to bottom of posts when using Trex Signature posts.

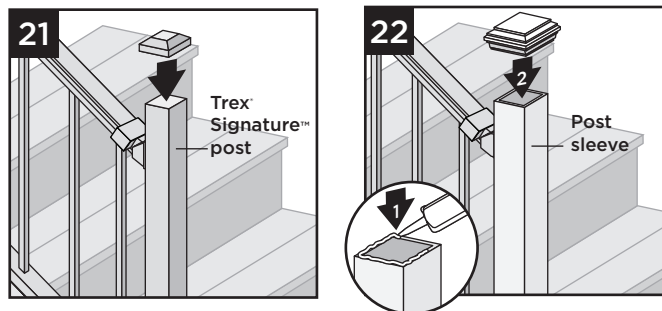

21. Attach post caps to Trex Signature posts (use of **rubber mallet** may be required for secure attachment).
22. Attach post caps to post sleeves using external grade PVC construction adhesive (apply adhesive on the inside self-centering/corner tabs).

ATTACHING CROSSOVER SWIVEL BRACKETS ON SIGNATURE POSTS

TREX SIGNATURE

1. Follow previous instructions for installation of lower stair rail into either fixed or swivel brackets.
2. Place two balusters into lower stair rail at each end of post.

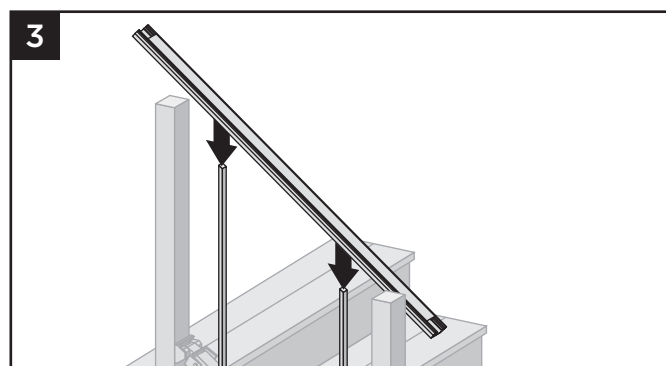
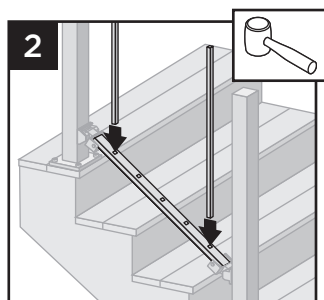

3. Position top stair rail onto balusters ensuring balusters are fully seated in top rail (position to side of post) and **ENSURE** that balusters are parallel with post.

4. Follow previous instructions marking and installation of either fixed or swivel bracket where this is required.

Attaching Stair Crossover Swivel Bracket to Post

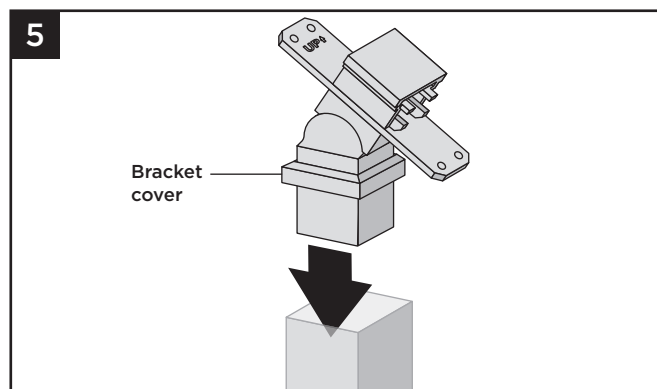

5. Insert stair crossover swivel bracket into post.

NOTE: Keep the bracket cover on when inserting this into post, this will cover the screw attachment area.

ATTACHING CROSSOVER SWIVEL BRACKETS TO POSTS/CONTINUED TREX SIGNATURE®

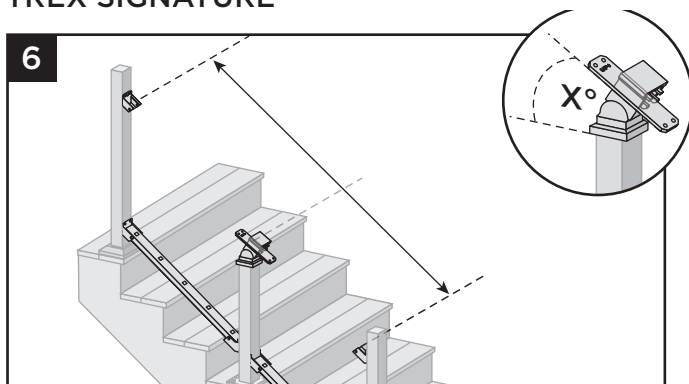

6. Determine location/height of the stair crossover swivel bracket by aligning the angle of this with the fixed brackets (or compound swivel brackets) already installed (posts can be cut if necessary).

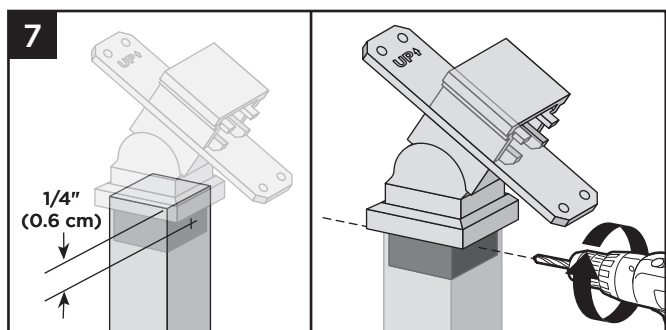

7. Once location/height is determined, center and pre-drill two holes (using a drill bit slightly smaller than that of self-tapping screw diameter) on opposite sides of post, approx. 1/4" (0.6 cm) from top of post. Drill through the post and into the stair crossover swivel bracket on each side.

NOTE: Slightly countersink pre-drilled holes to allow for flat head screw to seat flush on the post. This will allow cover to fit over screw heads.

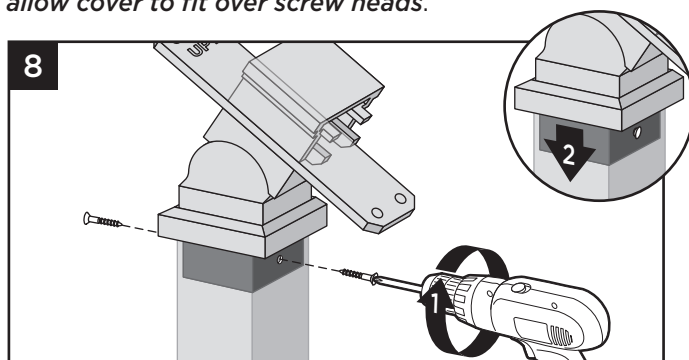

8. Attach stair crossover swivel bracket to post with two self-tapping screws (provided). Slide cover over post to hide screws.

ATTACHING RAILS IN CROSSOVER POST APPLICATIONS TREX SIGNATURE®

Cutting Top Stair Rail and Insert For Stair Post-to-Stair Crossover Post Configuration

When Using Fixed Stair Brackets:

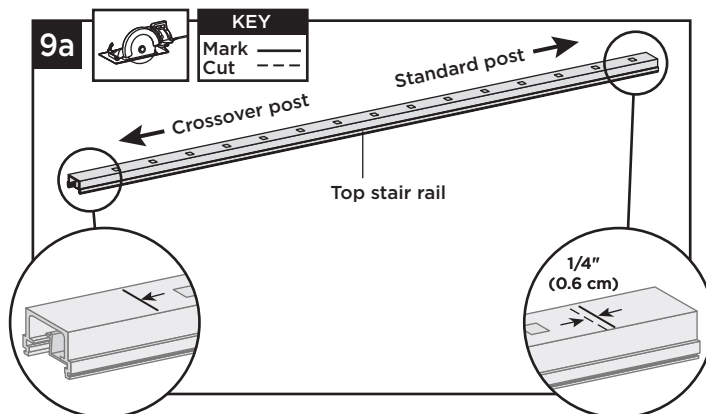

9a. Top stair rail along with rail insert must be cut differently on each side of the rail. Railing side that attaches to standard post should be cut 1/4" (0.6 cm) shorter than the mark to allow for fit into top rail bracket. Railing side that attaches to the crossover post should be cut directly on the mark to allow for fit into the crossover post bracket.

When using Upper Stair Swivel and Stair Crossover Swivel Brackets:

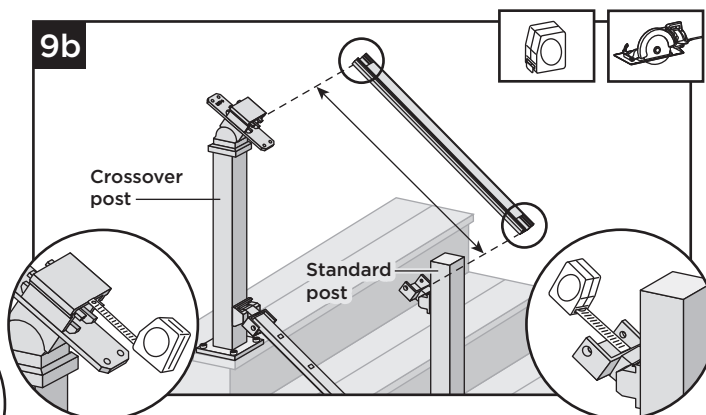

9b. When going from standard stair post to stair crossover post, measurement must be taken from inside of top horizontal stair swivel bracket to inside lip of stair crossover bracket. Crossover post will need to be modified to have swivel crossover bracket installed.

ATTACHING RAILS IN CROSSOVER POST APPLICATIONS CONTINUED TREX SIGNATURE®

Cutting Top Stair Rail and Rail Insert For Stair Crossover Post-to-Stair Crossover Post Configuration

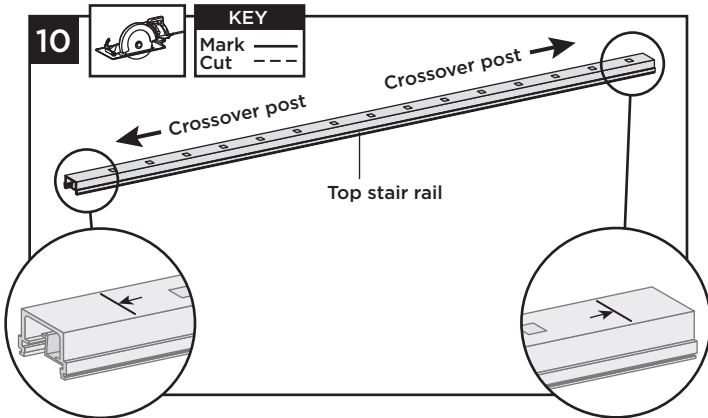

10. Cut each end of the top stair rail along with rail insert on the mark line to allow for fit into the crossover post bracket on each side.

Cutting Top Stair Rail Cover, and Attachment of Top Stair Rail Cover

11. Mark and cut top rail cover same length as top rail for all top rail configurations.

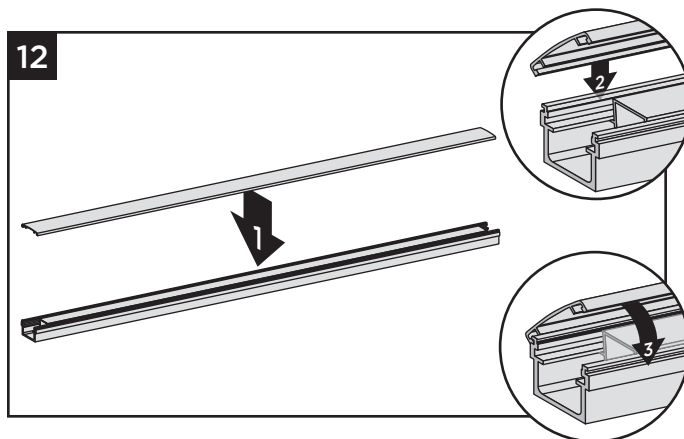
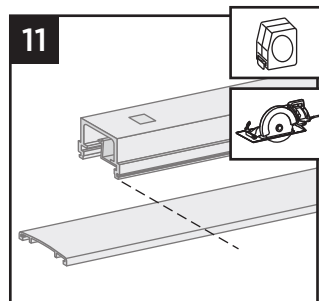

12. Attach "crowned" upper stair rail cover to upper stair rail by aligning cover on one side of rail. Then, starting from one end of stair rail, snap cover onto opposing slot working down length of stair rail. **GENTLY** tapping with a **rubber mallet** may facilitate fastening.

Installing Balusters into Bottom Stair Rail

13. Place balusters into holes in lower stair rail by snapping fully into place. In some cases, **GENTLE** tapping with a **rubber mallet** may facilitate fastening.

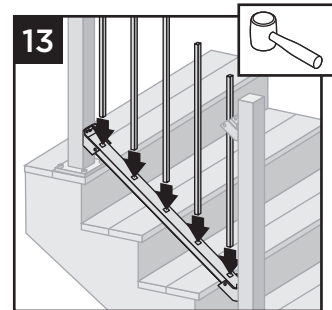

Attaching Upper Stair Rails

14. Working from one end of upper stair rail, snap balusters into upper stair rail working down length of rail.

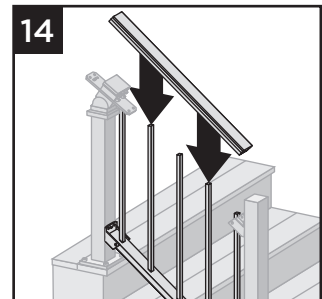

15a. For stair post-to-post configuration, attach top stair rail to top stair bracket (all types) using two self-tapping screws (*provided*) on each side of stair bracket.

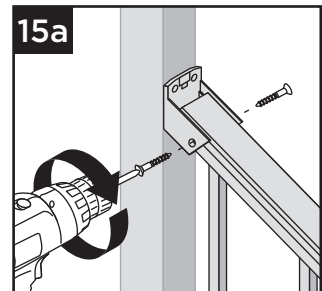

15b. For stair crossover post configuration, fasten upper stair rail to swivel crossover post bracket by installing screws diagonally through crossover stair bracket into upper rail using two self-tapping screws (*provided*) on each side.

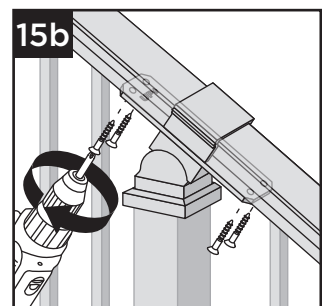

NOTE: Pre-drilling is required (7/64" [0.28 cm] drill bit) for attachment of stair railing to stair bracket.

ATTACHING RAILS IN CROSSOVER POST APPLICATIONS/CONTINUED TREX SIGNATURE®

Attachment of Skirts and Caps

16. Attach provided post skirt to bottom of posts when using Trex Signature posts.

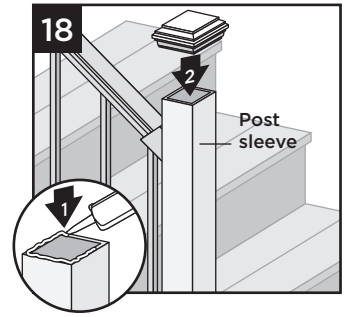
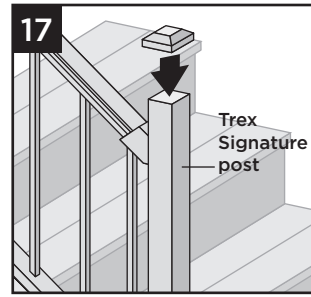
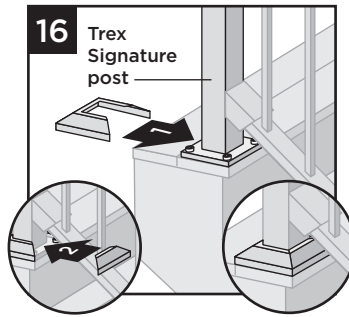

17. Attach post caps to Trex Signature posts (use of **rubber mallet** may be required for secure attachment).
18. Attach post caps to post sleeves using external grade PVC construction adhesive (apply adhesive on the inside self-centering/corner tabs).

HOW TO INSTALL COCKTAIL STAIR RAILING TREX SIGNATURE®

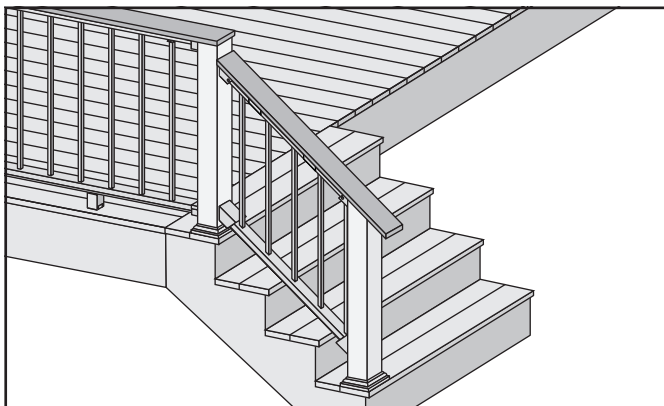

IMPORTANT NOTES:

- » *Only for use with pressure-treated 4 x 4 post (3.5" nominal square) and 4" x 4" (102 mm x 102 mm) post sleeve. Trex Signature posts, Trex post mounts or joist mount posts cannot be used with Trex Signature Cocktail stair railing. Cutting post and post sleeve only apply to the Cocktail style railing.*
- » *DO NOT CUT POST/POST SLEEVES UNTIL TOP RAILING AND COVER IS FULLY INSTALLED.*
- » *When referring to previous instructions referenced, disregard all crossover post instructions as these cannot be used with Cocktail railing.*

- » *THE DECK BOARD USED IN TREX SIGNATURE COCKTAIL RAILING WILL NEED TO TERMINATE AT THE TOP OF THE POST AS SHOWN ABOVE. THE DECK BOARD WILL HAVE TO BE TOENAILED INTO THE SIDE OF THE POST IN THESE AREAS USING 2 APPROPRIATE COMPOSITE DECKING SCREWS - PRE-DRILLING IS RECOMMENDED.*
- » *Do Not use Enhance for top board.*

Installing Pressure-treated Posts, Post Sleeves, and Skirts to Use with Trex Signature Railing

1. See instructions on page 105.

Installing Brackets

2. Follow previous stair instructions for the installation of desired brackets, making sure that all dimensions are calculated before installation, and ensuring deck board is placed in correct location. See instructions on pages 106 for fixed stair brackets and 110 for swivel stair brackets.

Cutting Bottom Stair Rail and Cover

3. See instructions on page 106 for fixed stair brackets and pages 110 for swivel stair brackets.

Installing Foot Block (when required)

4. See instructions on page 107.

Attachment of Bottom Stair Rail

5. See instructions on page 107 for fixed stair brackets and page 111 for swivel stair brackets.

How to Measure Top Stair Railings (WHEN REQUIRED)

6. See instructions on page 107 for fixed stair brackets and page 111 for swivel stair brackets.



HOW TO INSTALL COCKTAIL STAIR RAILING/CONTINUED

TREX SIGNATURE®

Cutting Top Stair Rail and Rail Insert When using Fixed Stair Brackets

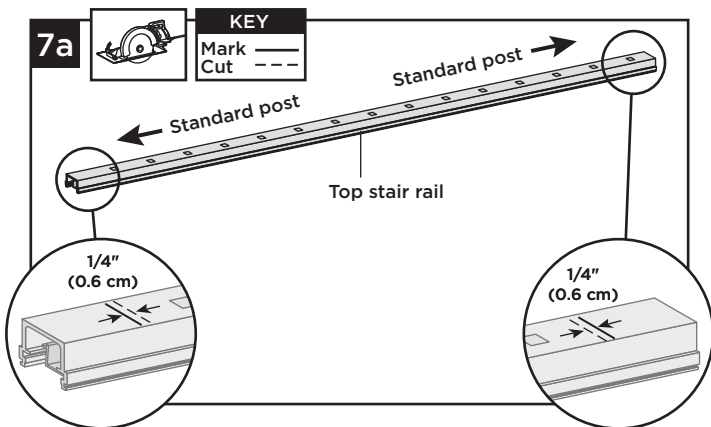

7a. Cut each end of top stair rail along with rail insert 1/4" (0.6 cm) shorter than mark to allow for fit into top stair rail bracket.

NOTE: THE TOP RAIL WILL NEED TO BE CUT AT APPROPRIATE ANGLE ON THE END OF THE RAIL THAT CONNECTS TO THE UPPER FIXED BRACKET, SO THAT WHEN THE RAIL IS INSTALLED IT SITS FLUSH WITH THE END OF THE BRACKET AS SHOWN.

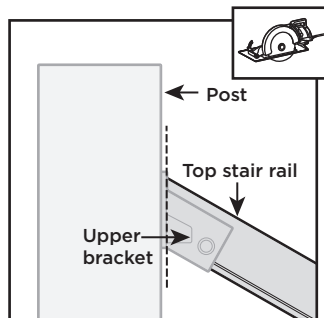

Cutting Top Stair Rail and Rail Insert When using Upper Stair Swivel and Compound Swivel Brackets

7b. See instructions on page 111.

Cutting Top Stair Rail Cover, and Attachment of Top Stair Rail Cover

8. See instructions on page 108.

Installing Balusters into Bottom Stair Rail

9. See instructions on page 109.

Attaching Upper Stair Rails

10. See instructions on page 109.

Cutting Post and Post Sleeve and Attaching Deck Board to Top Rail

11. Cut post and post sleeves at proper angle so these are flush with the top of the top brackets and/or top rail cover. BE CAREFUL **NOT** to CUT brackets.

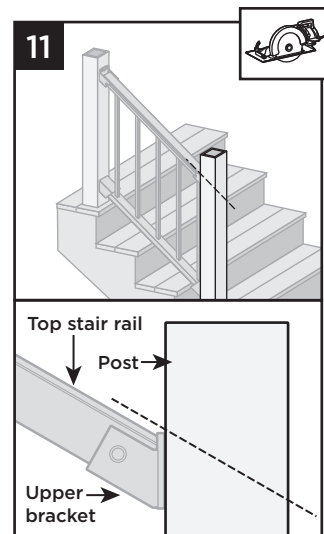

12. Place deck boards over top rails. PLACE DECK BOARD ON TOP RAIL TO CHECK FOR PROPER FIT AND RAIL CLEARANCE AT BRACKET LOCATIONS. DECK BOARD MAY REQUIRE EITHER A NOTCH CUT ON THE UNDERSIDE OR SLIGHT PLANING ON THE UNDERSIDE TO ALLOW DECK BOARD TO CLEAR TOPS OF BRACKETS AND SIT FLUSH ON TOP OF POSTS AND RAILS. Attach boards on each post with Trex-recommended composite screws (quantity of 2 per each board end).

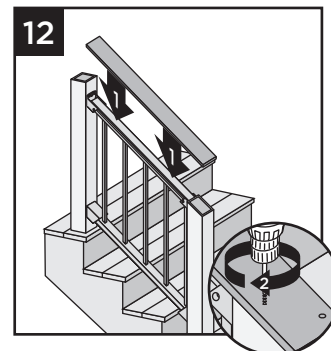

13. Secure boards to top rail using Trex Signature Cocktail Bracket (sold separately). Ensure that there is a bracket at each end of the stair railing section, then space brackets approximately every 24" and attach with 4 screws provided.

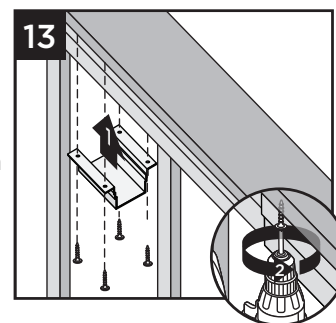

NOTE: Pre-drilling before attachment is recommended.

HOW TO INSTALL COCKTAIL STAIR RAILING/CONTINUED TREX SIGNATURE®

14. Use scarf cut for posts where two deck boards meet.

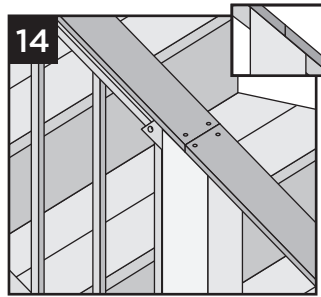

NOTES:

- » Leave 1/8" (3 mm) gap between deck boards.
- » Deck boards can overhang end of last post maximum 1/2" (13 mm).

15. Where deck board terminates at top of post horizontal deck board, PREDRILL and toenail two approved composite deck screws as shown into post, being careful to avoid hitting stair bracket.

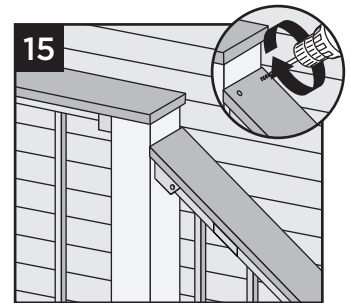

Attachment of Bracket Covers and Skirts

16. See instructions on page 109.

NOTE: Top Bracket Covers are not attached in this configuration.

HOW TO INSTALL TRADITIONAL STAIR RAILING TREX SIGNATURE®

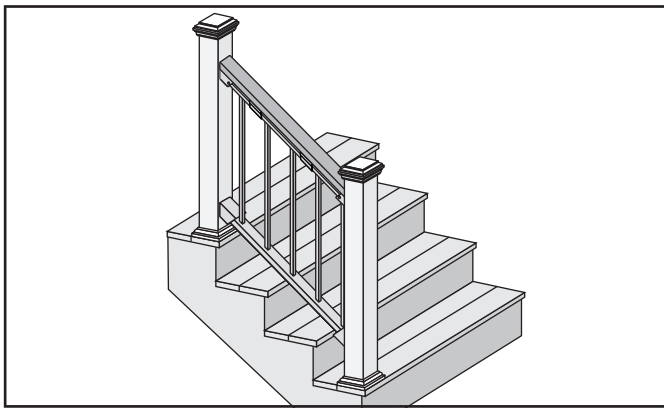

IMPORTANT NOTE:

- » Only for use with pressure-treated 4 x 4 post (3.5" nominal square) and 4" x 4" (102 mm x 102 mm) or 6" x 6" post sleeve. Trex Signature Posts, Trex Post Mounts or Joist Mount Posts cannot be used with Trex Signature Traditional railing.

Installing Standard Trex Signature Stair Posts, or Pressure-treated Post

1. See instructions on page 106.

Installing Lower Fixed Stair Brackets

- 2a. See instructions on pages 106.

Installing Lower Stair Swivel and Compound Swivel Brackets

- 2b. See instructions on page 110.

How to Measure Bottom Stair Railings Fixed Stair Brackets

- 3a. See instructions on page 105.

How to Measure Bottom Stair Railings When using Stair Swivel and Compound Swivel Brackets

- 3b. See instructions on page 110.

Cutting Bottom Stair Rail, Bottom Stair Rail Cover When Using Fixed Stair Brackets

- 4a. See instructions on page 106.

Cutting Bottom Stair Rail, Bottom Stair Rail Cover When Using Stair Swivel and Compound Swivel Brackets

- 4b. See instructions on page 110.

Attaching Foot Block (when required)

5. See instructions on page 107.

Attachment of Bottom Stair Rail Cover and Bottom Stair Rail to Fixed Brackets

- 6a. See instructions on page 107.

Attachment of Bottom Stair Rail Cover and Bottom Stair Rail to Swivel and Compound Swivel Brackets

- 6b. See instructions on page 111.

Installing Upper Fixed Stair Brackets and Measuring Upper Rail

- 7a. See instructions on pages 107.

Installing Upper Swivel and Swivel Compound Stair Brackets and Measuring Upper Rail

- 7b. See instructions on pages 111.



HOW TO INSTALL TRADITIONAL STAIR RAILING/CONTINUED

TREX SIGNATURE®

Cutting Top Stair Rail and Rail Insert When Using Fixed Stair Brackets

8a. See instructions on page 108.

Cutting Top Stair Rail and Rail Insert When Using Swivel Compound Stair Brackets and Measuring Upper Rail

8b. See instructions on page 111.

Installing Balusters into Bottom Stair Rail When Using Fixed Stair

9a. See instructions on page 109.

Installing Balusters into Bottom Stair Rail When Using Swivel and Compound Swivel Brackets

9b. See instructions on page 112.

Attaching Upper Stair Rails When Using Fixed Stair Brackets

10a. See instructions on page 109.

Attaching Upper Stair Rails When Using Swivel Compound Stair Brackets

10b. See instructions on page 112.

Attaching 2 x 4 to Top Rail

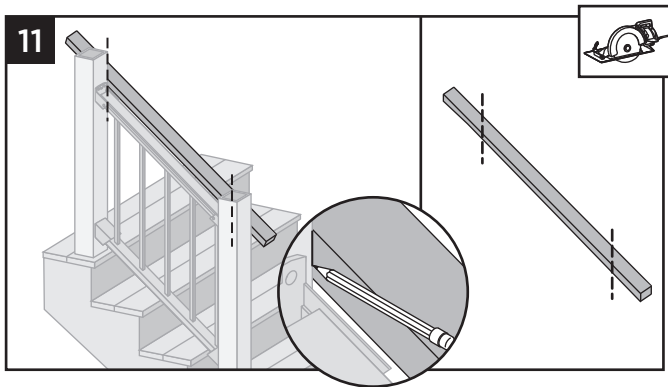

11. Place 2 x 4 beside top rail. Mark and cut (both ends need to be cut on an angle for proper fit).

12. Place 2 x 4 on Trex Signature top stair rail.

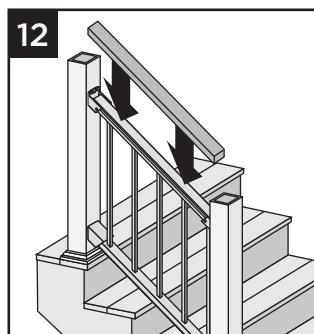

13. Secure 2 x 4 to top rail using Trex Signature Cocktail Bracket (sold separately). Ensure that there is a bracket at each end of the railing section, then space brackets approximately every 24" and attach with 4 screws provided.

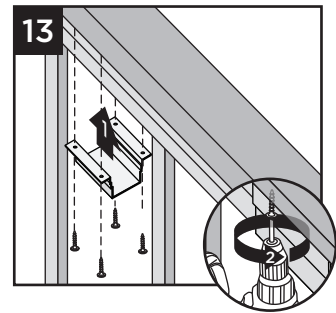

NOTE: Pre-drilling before attachment is recommended.

14. Pre-drill a pilot hole and toenail 2-1/2" (6.4 cm) screw at each end of 2 x 4 into post on back side of rail (side not facing decking).

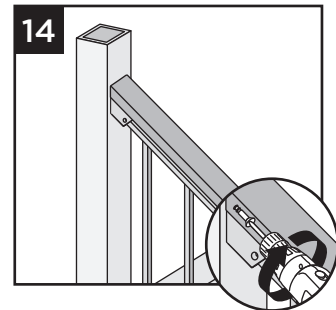

Attachment of Lower Stair Bracket Covers, Skirts, and Caps Fixed Bracket

15a. See instructions on page 109.

Attachment of Lower Stair Bracket Covers, Skirts, and Caps Swivel or Compound Swivel Bracket

15b. See instructions on page 113.

NOTE: Top Bracket Covers are not attached in this configuration.

HORIZONTAL CURVED RAILING

TREX SIGNATURE®

NOTES:

- » DESIGN AND FABRICATION WILL BE HANDLED BETWEEN TREX COMMERCIAL PRODUCTS (TCP) AND THE CONTRACTOR/CUSTOMER. FOR MORE INFORMATION VISIT TREX.COM OR CALL 1-800 BUY TREX.
- » EVERY SECTION IS CUSTOM FABRICATED FOR EACH SPECIFIC JOB. CURVED RAILS ARE DESIGNED WITH 8' LENGTH RAILS, BUT DUE TO MANUFACTURING PROCESS THIS WILL ALLOW 6' USABLE SECTIONS. THUS, WHEN DESIGNING CURVED RAILING, SPANNING IS 6' MAXIMUM CURVED SPAN.
- » SIGNATURE CURVED RAILINGS CAN ONLY BE USED WITH HORIZONTAL RAILINGS. STAIR RAILINGS CANNOT BE CURVED.
- » WHEN INSTALLING SIGNATURE CURVED RAILING, ONLY HORIZONTAL SWIVEL BRACKETS OR HORIZONTAL SWIVEL TABLESS BRACKETS (PREFERRED) CAN BE USED.
- » FOOTBLOCKS ARE REQUIRED FOR EVERY SIGNATURE CURVED RAIL SECTION. THUS THESE RAILING SPANS MUST BE INSTALLED OVER THE DECKING FRAME OR ON INSIDE OF RIM JOIST.
- » CANNOT BE USED WITH TREX JOIST MOUNT POSTS THAT ARE ATTACHED OUTSIDE OF THE RIM JOIST.

PARTS

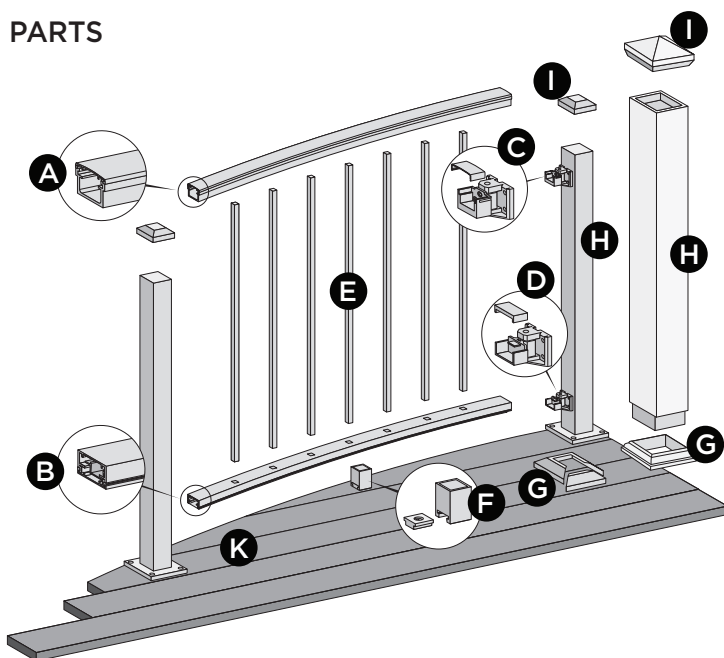

BALUSTER OPTIONS

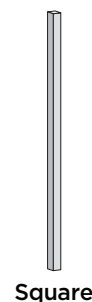

NOTES: This is an overview of CURVED railing components for Signature Horizontal applications.

- A. Trex Signature curved top rail
- B. Trex Signature bottom rail and flat cover
- C. Trex Signature top rail bracket and cover
- D. Trex Signature bottom rail bracket and cover
- E. Trex Signature balusters (square)
- F. Trex Signature foot block**
- G. Trex Signature post skirt or post sleeve skirt*
- H. Trex Signature post*
 - 36" (actual length 37" [94.0 cm])
 - 42" (actual length 43" [109.2 cm])
 - or Trex post sleeve***
 - 36" (actual length 40" [102 cm])
 - 42" (actual length 46" [117 cm])

- I. Trex Signature post cap or post sleeve cap*

* Item not included in Trex Signature Railing kits.

** One required per each curved railing section.

*** Both 4" x 4" (10.2 cm x 10.2 cm) and 6" x 6" (15.2 cm x 15.2 cm) post sleeves are designed to fit over 4" x 4" pressure-treated post.

NOTE: If installing 42" (106.7 cm) railing, and using pressure-treated posts with Trex post sleeves, ensure that a longer pressure-treated post is used along with longer post sleeve, both cut to a height of 46" (116.8 cm) from decking surface.

NOTE: MUST USE TREX DECK MOUNT POST HARDWARE AND METAL PLATE WHEN ATTACHING TREX SIGNATURE POSTS.

HOW TO INSTALL HORIZONTAL CURVED RAILING/CONTINUED

TREX SIGNATURE®

Installing Posts and Swivel Brackets

1. Install posts and horizontal swivel brackets as stated within Trex Signature Post and Horizontal Swivel Bracket Instructions.

How to Measure and Cut Bottom and Top Rails

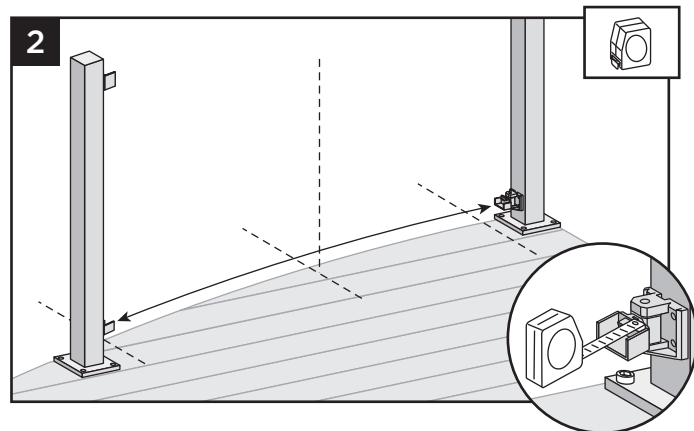

2. With brackets in correct swivel location, measure distance from inside of bracket to inside of bracket. **BEFORE CUTTING, ENSURE THAT BALUSTER HOLES ON BOTH BOTTOM AND TOP RAIL LINE UP.**

Attachment of Foot Block

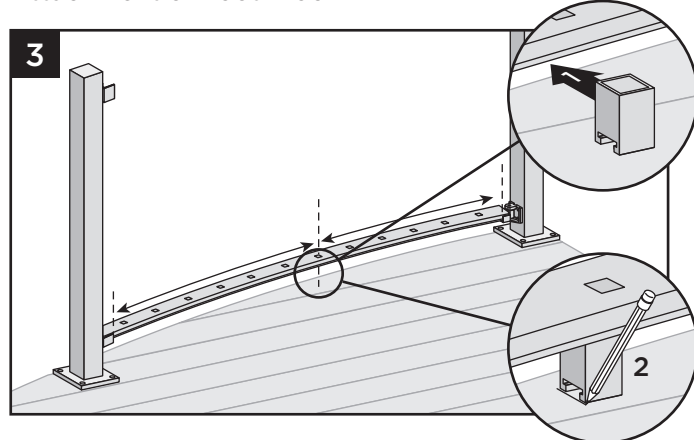

3. Temporarily set bottom rail into bottom brackets, and place foot block under bottom rail centered between bottom brackets. Mark to provide placement location of base. Remove bottom rail.

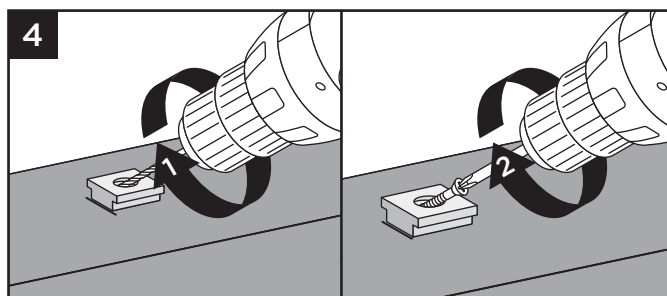

4. Place base (smaller side facing down) on decking surface. Pre-drill using a 3/16" bit. Attach base of foot block using one screw at an angle through base and into decking.

5. After attached, use a rubber mallet along with scrap piece of wood to tap foot block until it locks into place.

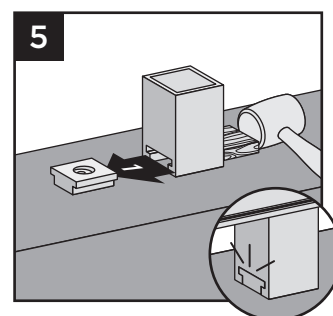

Installing Lower Rail to Brackets

If using Tabbed Lower Swivel Brackets:

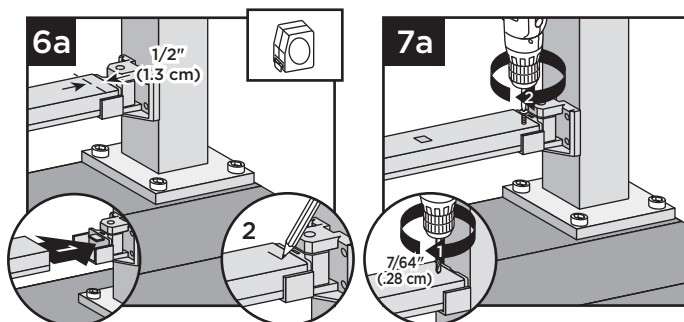

- 6a. Set bottom rail into bottom brackets. Tabs on brackets will be inside of bottom rail (not shown when railing is attached). To ensure fit into tab, measure and mark 1/2" (1.3 cm) out from end of rail/inside edge of bracket.
- 7a. Attach bottom rail to bottom bracket by fastening through marked measurement on top of rail into tab on bottom bracket using one self-tapping screw on each side (*provided*).

NOTE: Pre-drilling is recommended (7/64" [0.28 cm] drill bit) for attachment of railing to bracket.

HOW TO INSTALL CURVED RAILING/CONTINUED

TREX SIGNATURE™ STANDARD

NOTE: If there is no room to get drill in between last baluster and post:

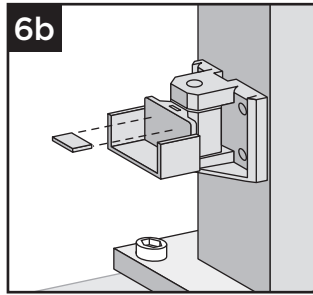

6b. Break or cut the bottom tab off the bottom brackets.

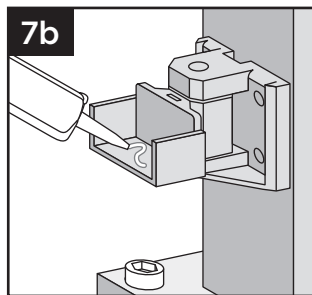

7b. Put a dab of silicone in the basket of the bottom of the bracket to prevent rattle.

If using Tabless Lower Swivel Brackets:

6c. Place adhesive strips (provided) into bottom rail brackets, and then place bottom rail into brackets (proceed to step 8).

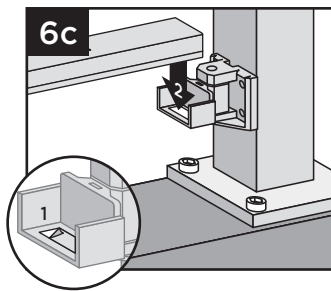

NOTE: Make sure surface is clean and dry.

Installing Balusters into Bottom Rail

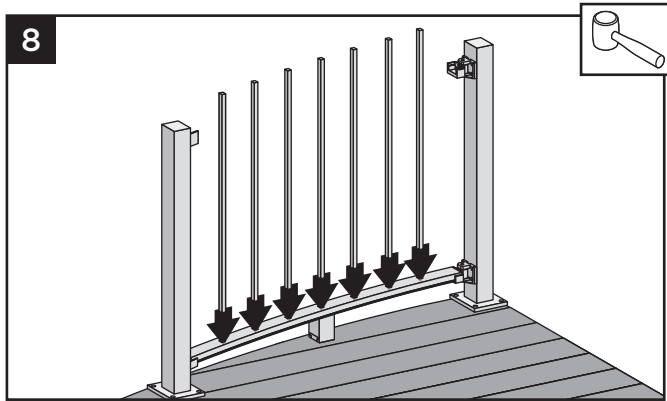

8. Place balusters into holes in lower rail by snapping fully into place.

Attach Upper Railings

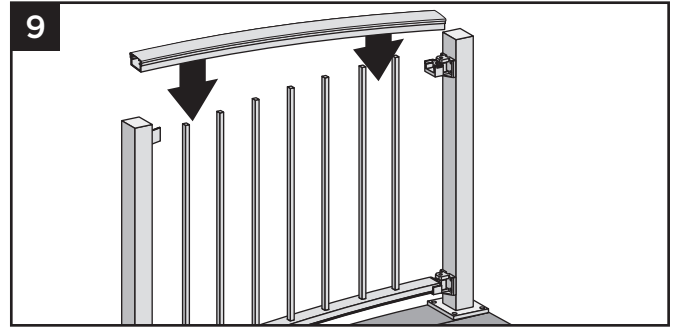

9. Working from one end of upper rail, snap balusters into upper rail, working down length of curved rail.

10a. If there is room to get drill in between last baluster and post, pop out access panel on underside of top bracket, and attach top rail to bracket using two self-tapping screws each side (provided). Screw from the bottom up into the top rail.

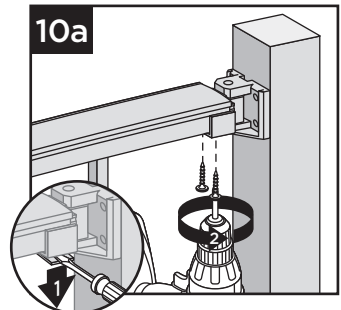

NOTE: Pre-drilling is required (7/64" [0.28 cm] drill bit) for attachment of railing to bracket.

If there is no room to get drill in between last baluster and post:

10b. Use a step bit or dremel and create two small holes in top rail. **NOTE: DO NOT EXCEED THE WIDTH OF THE TOP HORIZONTAL SWIVEL BRACKET COVER OR DRILL TOO CLOSE TO EDGE OF RAIL.** Attach top rail to bracket using two self-tapping screws on each side (provided).

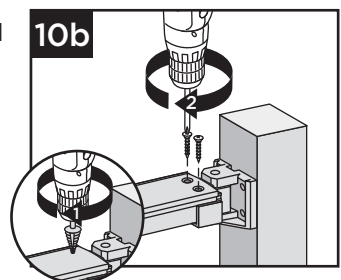

NOTE: Pre-drilling is required (7/64" [0.28 cm] drill bit) for attachment of railing to bracket.

HOW TO INSTALL HORIZONTAL CURVED RAILING/CONTINUED TREX SIGNATURE®

11. Install upper and lower bracket covers. If self-tapping screws were installed from above on top rail, bracket cover will hide the screw hole locations.

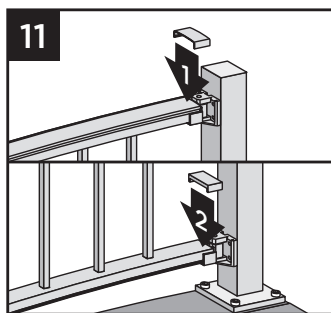

13. Attach post caps to Signature posts. (A **rubber mallet** may be required for secure attachment.)

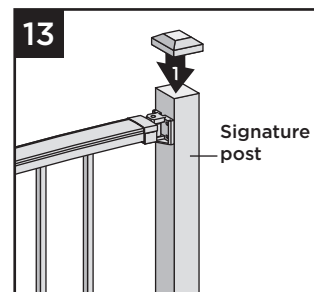

Attachment of Skirts and Caps

12. Attach provided post skirt to bottom of posts when using Signature posts.

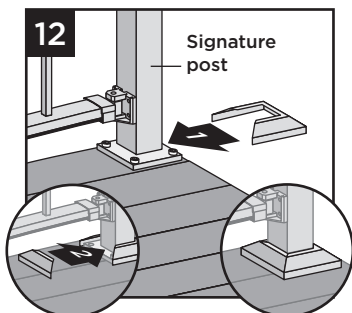

14. Attach post caps to post sleeves using external-grade PVC construction adhesive (apply adhesive on the inside self-centering/corner tabs).

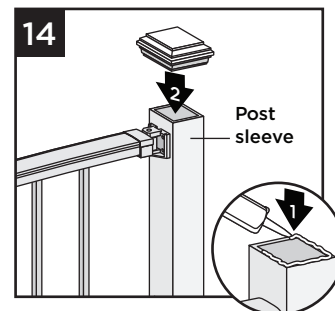

TREX SIGNATURE® PANELS

NOTES:

- » TREX SIGNATURE RAILINGS ARE DESIGNED TO BE ATTACHED WITH POSTS INSTALLED AT A CLEAR SPAN OF 6' (1.83 M) OR 8' (2.44 M). THUS THESE RAILING SPANS MUST BE INSTALLED OVER THE DECKING FRAME OR ON INSIDE OF RIM JOIST.
- » IF INSTALLING AT EXACT SPAN LENGTHS OF 6' (1.83 M) OR 8' (2.44 M), AND USING POST-TO-POST CONFIGURATION, THE BOTTOM RAIL WILL NOT NEED TO BE CUT, BUT THE TOP RAIL WILL NEED TO BE MEASURED AND CUT.
- » IF INSTALLING AT EXACT SPAN LENGTHS OF 6' (1.83 M) OR 8' (2.44 M), AND USING CROSSOVER POST CONFIGURATION (SPANS FROM ONE CROSSOVER POST TO ANOTHER CROSSOVER POST), BOTH THE BOTTOM RAIL AND TOP RAIL WILL NOT NEED TO BE CUT.
- » IN ADDITION, AT ALL FINAL END POST CONFIGURATIONS, TOP RAIL WILL NEED TO BE MEASURED AND CUT.
- » SEE INFORMATION WITHIN DETAILED INSTRUCTIONS FOR MORE INFORMATION.
- » SEE PAGE 51 FOR SKU NUMBERS.

PARTS

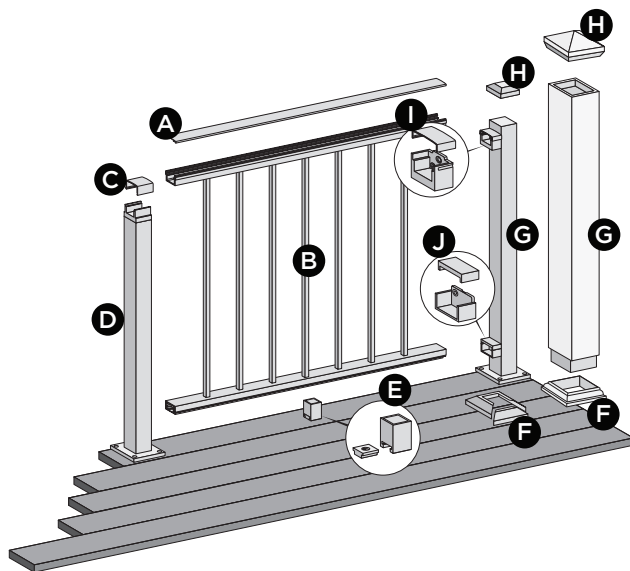

- A. Trex Signature upper rail cover*
 - 6' (actual length 73-1/2" [1867 mm])
 - 8' (actual length 97-1/2" [2477 mm])
- B. Trex Signature Panel (includes top and bottom railings and square balusters)
- C. Crossover bracket cover (supplied with crossover post)
- D. Trex Signature crossover post**
 - 36" (actual length 34-1/2" [876 mm])
 - 42" (actual length 40-1/2" [1029 mm])
- E. Trex Signature foot block***
- F. Trex Signature post skirt or post sleeve skirt**
- G. Trex Signature post**
 - 2-1/2"
 - 36" (actual length 37" [940 mm])
 - 42" (actual length 43" [1092 mm])
 - or Trex 4x4 post sleeve**
 - 36" (actual length 40" [102 cm])
 - 42" (actual length 46" [117 cm])
- H. Trex Signature post cap or post sleeve cap**

TOOLS NEEDED

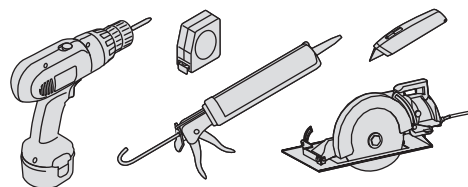

NOTES:

- » Assembled Trex Signature Panels DO NOT come with foot blocks. You must purchase foot blocks separately. SKU - BKALFTBLK (one per panel required on spans greater than 6', see note below***).
- » Assembled Trex Signature Panels DO NOT come with brackets and screws. You must purchase the horizontal rail hardware separately. SKU - BKFHBTALPNL (one per panel).

- I. Trex Signature upper rail bracket and cover
- J. Trex Signature lower rail tabless bracket and cover

* Covers are slightly longer to accommodate crossover post applications.

** Item not included in Trex Signature Panel kits. Both 4" x 4" (102 mm x 102 mm) and 6" x 6" (152 mm x 152 mm) post sleeves are designed to fit over 4" x 4" pressure-treated post.

*** Required ONLY for all clear span applications over 6' (1.83 m) when fixed baluster is centered or unsupported spans greater than 5' (1.52 m). For example, if an 8' (2.44 m) panel is cut into a 5-1/2' (1.68 m) section, it would require a foot block due to the off-center placement of the fixed baluster.

NOTE: If installing 42" (1067 mm) railing, and using pressure-treated posts with Trex post sleeves, ensure that a longer pressure-treated post is used along with longer post sleeve, both cut to a height of 46" (1168 mm) from decking surface.

BRACKET HARDWARE - HORIZONTAL APPLICATIONS (INCLUDING HORIZONTAL SWIVEL BRACKETS) TREX SIGNATURE®

HORIZONTAL RAILING HARDWARE

- AA. Tabless Lower rail bracket
- BB. Lower rail bracket cover
- CC. Upper rail bracket cover
- DD. Upper rail bracket

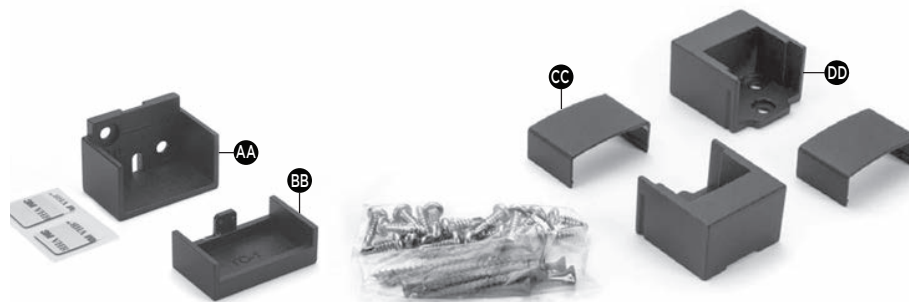

FOOT BLOCK COMPONENTS

- EE. Foot block base
- FF. Foot block support

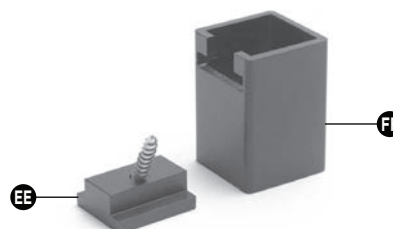

HORIZONTAL SWIVEL HARDWARE

- GG. Swivel base
- HH. Horizontal swivel bracket top rail
- II. Horizontal swivel bracket top rail cover
- JJ. Horizontal swivel bracket bottom rail cover
- KK. Horizontal swivel bracket bottom rail with tab or tabless bracket (2 options)
- LL. Swivel base cover

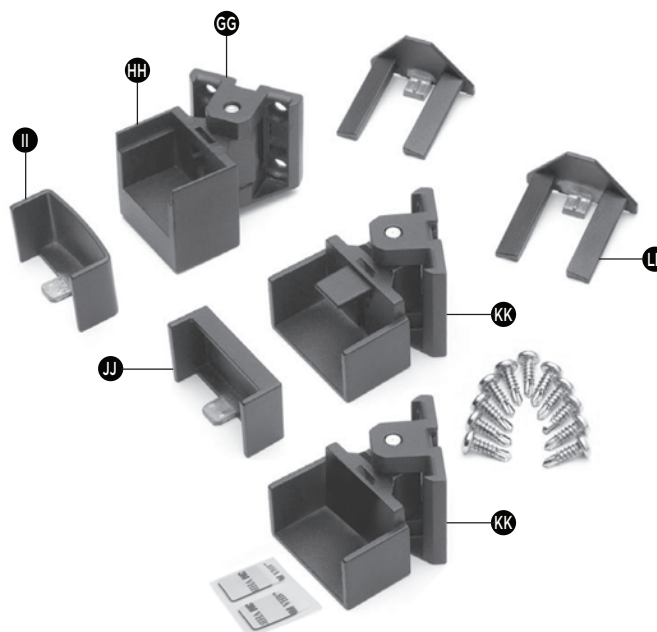

NOTE: For measurements and detailed horizontal swivel hardware installation instructions, please see the complete Trex Signature installation section.

HOW TO INSTALL PANELS

TREX SIGNATURE®

NOTE: FOR EASE OF INSTALLATION, IT IS RECOMMENDED THAT YOU USE THE TREX SIGNATURE RAIL TEMPLATES TO ATTACH BRACKETS (SOLD SEPARATELY).

Attach Brackets Using Trex Signature Posts

TIP: Use a clamp to help hold brackets in place while fastening with screws.

1. Measure 1-3/8" (3.5 cm) from top of post base plate or 1-7/8" (4.8 cm) from decking surface. Mark with light line.

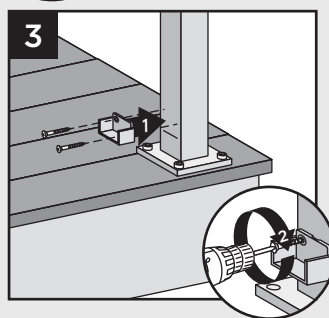
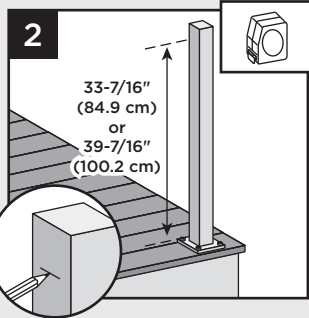
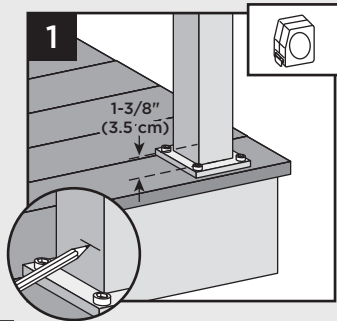

2. Measure up from post base plate 33-7/16" (84.9 cm) for 36" (92 cm) rail height or 39-7/16" (100.2 cm) for 42" (107 cm) rail height. Mark with light line.

NOTE: If measuring from decking surface, measure up 33-15/16" (86.2 cm) for 36" (92 cm) rail height or 39-15/16" (101.4 cm) for 42" (107 cm) rail height.

3. Center lower bracket on post **above** the marked line and attach using two self-tapping screws (provided).
4. Center upper bracket on post **above** marked line and attach using (3) self-tapping screws (provided).

NOTE: Upper bracket is not required on crossover post configuration.

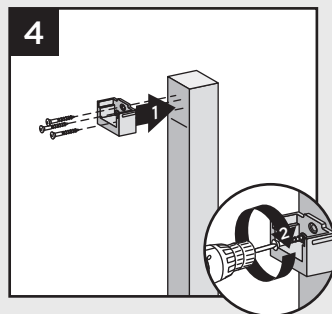

Attach Brackets Using Pressure-Treated Posts and Post Sleeves

TIP: Use a clamp to help hold brackets in place while fastening with screws.

1. Measure 1-7/8" (4.8 cm) up from deck surface to bottom of bracket. Slide skirt up to allow for proper measurement. Mark with light line.

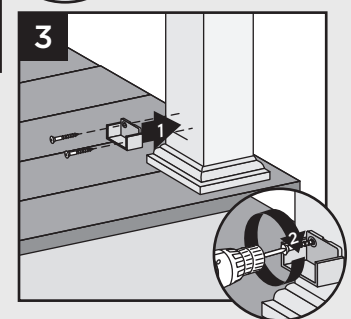
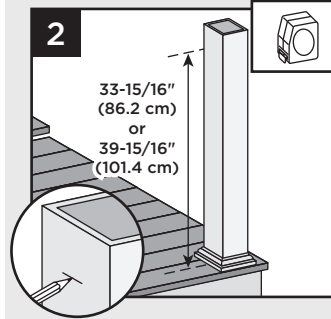
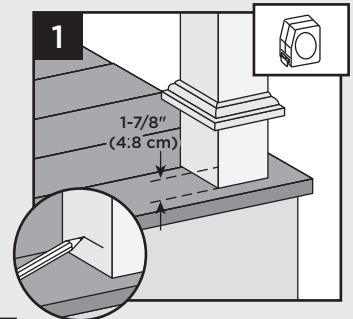

2. Measure up from decking surface 33-15/16" (86.2 cm) for 36" (92 cm) rail height or 39-15/16" (101.4 cm) for 42" (107 cm) rail height. Mark with light line.

NOTE: Push skirt back down onto surface of decking **BEFORE ATTACHING BRACKETS.**

3. Center lower bracket on post **above** the marked line and attach using two 2" (51 mm) wood screws (provided).
4. Center upper bracket on post **above** marked line and attach using three 2" (51 mm) wood screws (provided).

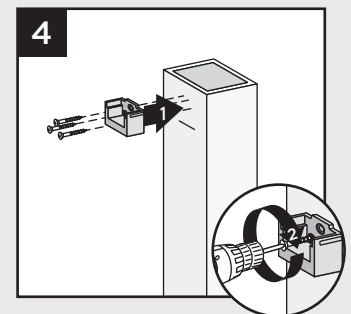

HOW TO INSTALL PANELS/CONTINUED TREX SIGNATURE®

How to Measure and Cut Bottom and Top Railings of Trex Signature Panel (When REQUIRED)

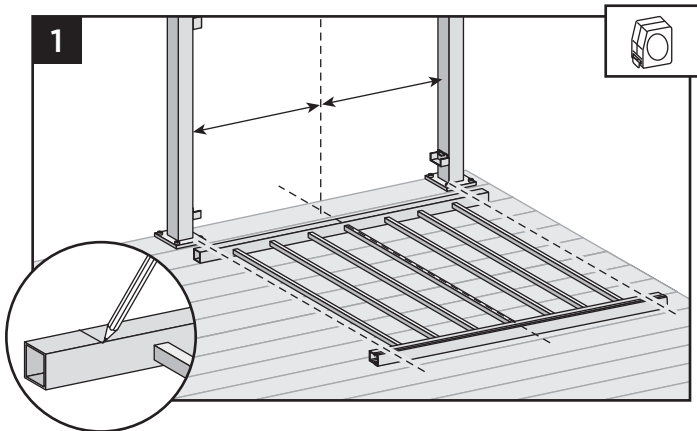

1. Position panel between posts and align with bottom bracket. Align center baluster with middle of span between posts (this will allow for equal spacing between end balusters and each post). Mark bottom and top rail at each end.

NOTE: If the end balusters fall too close to the brackets, the center point can be adjusted one baluster to the left or right to allow more room.

Cutting Bottom Rail

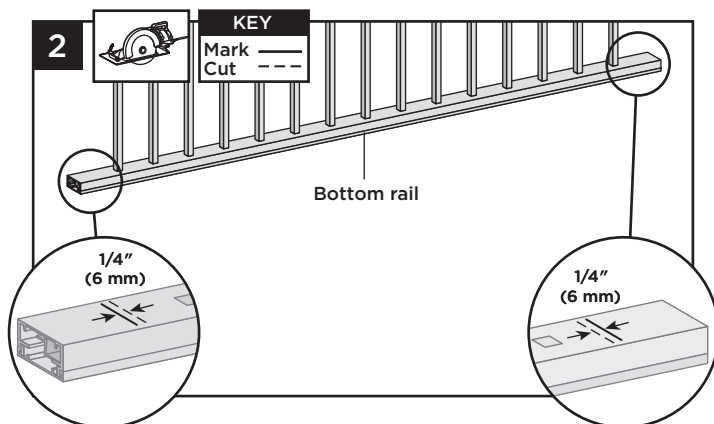

2. Using a saw equipped with a non-ferrous metal blade, cut each end of bottom rail and bottom rail insert 1/4" (6 mm) shorter than mark on each end to allow for fit into bottom rail brackets.

Cutting Top Rail

Option 1:

For Post-to-Post Configuration

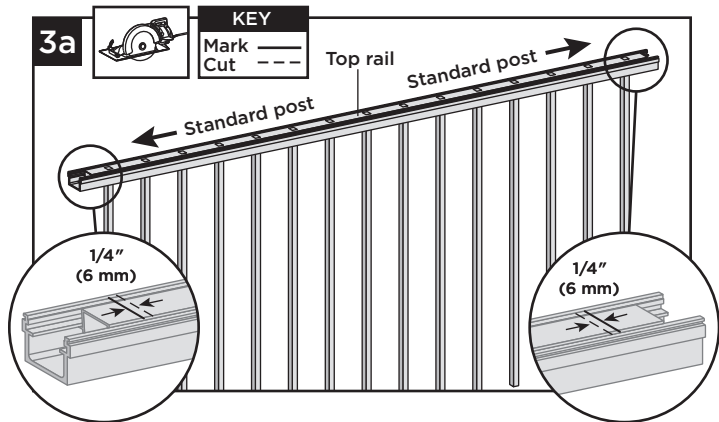

- 3a. Using a saw equipped with a non-ferrous metal blade, cut each end of top rail 1/4" (6 mm) shorter than mark to allow for fit into top rail brackets.

Cutting Top Rail

Option 2:

For Post-to-Crossover Post Configuration

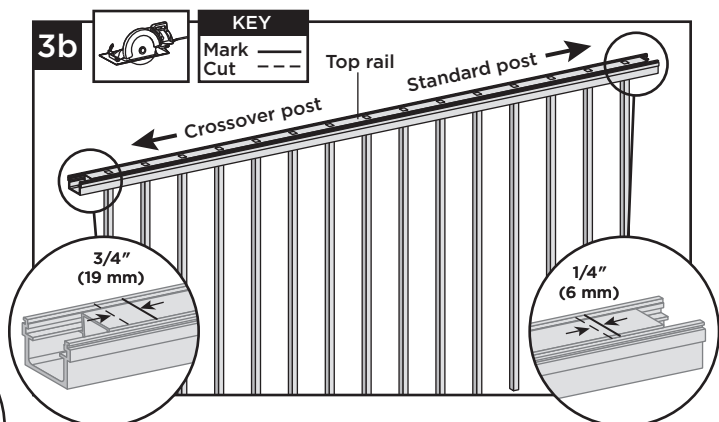

- 3b. Top rail must be cut differently on each side of the rail. Railing side that attaches to standard post should be cut 1/4" (6 mm) shorter than the mark to allow for fit into top rail bracket. Railing side that attaches to the crossover post should be cut 3/4" (19 mm) **LONGER** than the mark to allow for fit into the crossover post bracket.

HOW TO INSTALL PANELS/CONTINUED TREX SIGNATURE®

Cutting Top Rail

Option 3:

For Crossover Post-to-Crossover Post Configuration

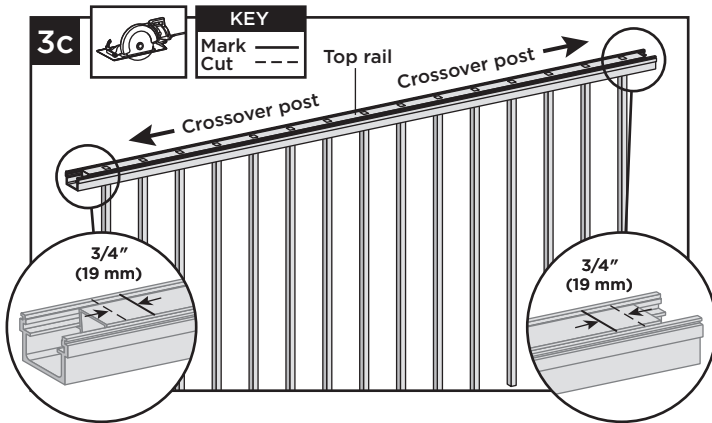

3c. Cut each end of top rail $\frac{3}{4}$ " (19 mm) **LONGER** than the mark to allow for fit into the crossover post bracket on each side.

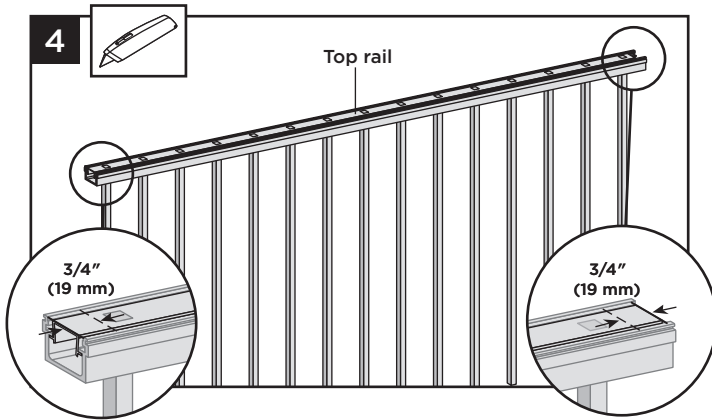

4. Using razor knife or other cutting tool, cut rail insert $\frac{3}{4}$ " (19 mm) **FROM EACH SIDE**.

5. Mark and cut top rail cover same length as top rail for all top rail configurations.

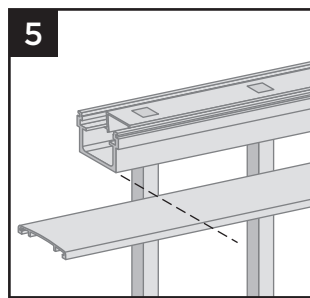

Attaching Foot Block (when required)

(One Foot Block is required for all spans over 6')

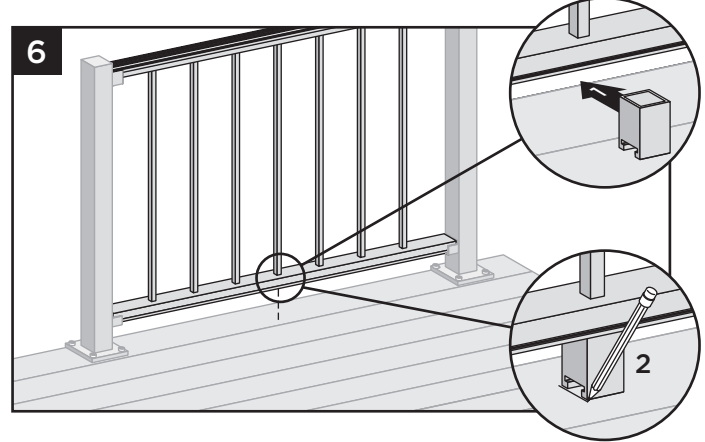

6. Temporarily place panel onto brackets. To ensure correct location, place foot block under center of bottom panel rail. Mark to provide placement location of base.

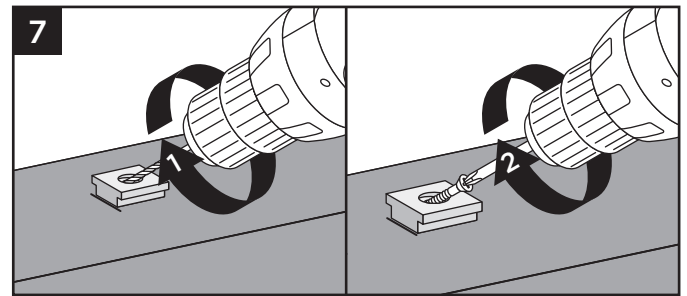

7. Remove railing panel and place base (smaller side facing down) on decking surface. Pre-drill using a $\frac{3}{16}$ " bit. Attach base of foot block using one screw at an angle through base and into decking.

8. After attached, use a **rubber mallet along with scrap piece of wood** to tap foot block until it locks into place.

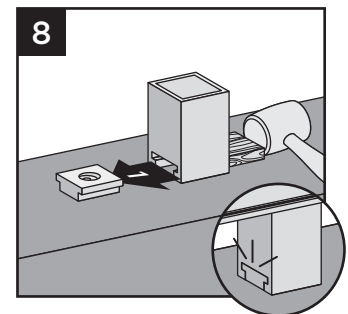

Installing Trex Signature Panel Using Lower Rail Tableless Bracket

9. Peel backings from adhesive strip provided and place inside the bottom bracket.

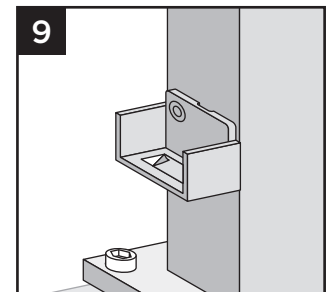

NOTE: Make sure surface is clean and dry.

HOW TO INSTALL PANELS/CONTINUED TREX SIGNATURE®

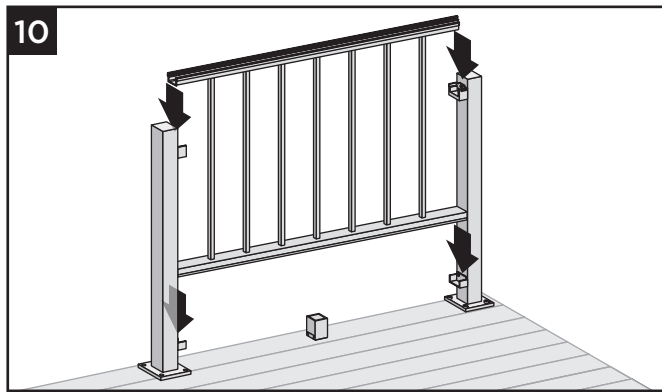

10. Place panel in bottom and top brackets.

11. For post-to-post configuration, fasten upper rail to each bracket by installing screws diagonally through upper rail into bracket using two self-tapping screws each side (provided with bracket kit).

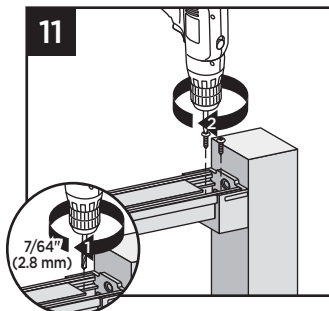

12. For crossover post configuration, fasten upper rail to crossover post by installing screws diagonally through upper rail into post using two self-tapping screws each side (provided with bracket kit).

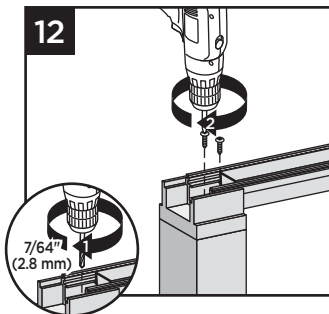

NOTE: Pre-drilling is recommended (7/64" [2.8 mm] drill bit) for attachment of railing to bracket.

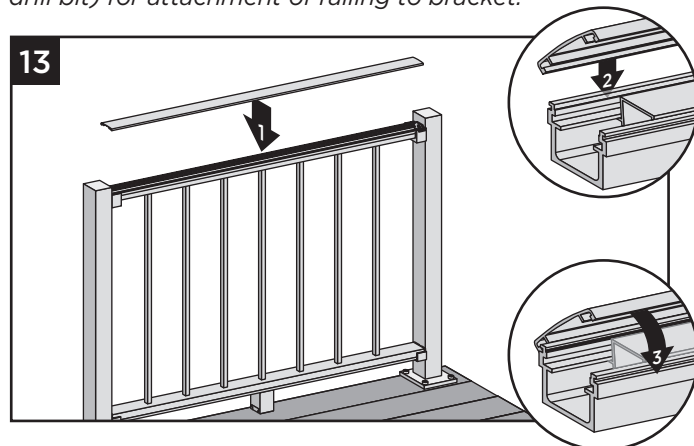

13. Attach upper rail cover to upper rail by aligning cover on one side of rail. Then, starting from one end of rail, snap cover onto opposing slot working down length of rail. **GENTLE** tapping with a **rubber mallet** may facilitate fastening.

Attachment of Bracket Covers, Skirts, and Caps

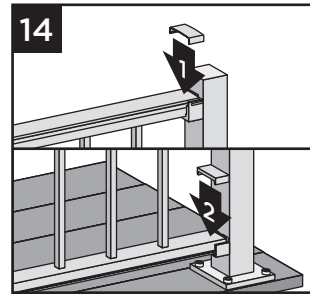

14

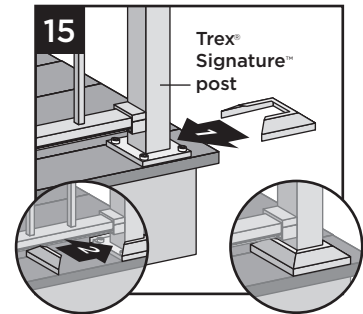

15

14. Attach corresponding bracket covers over opening in upper and bottom rails.

15. Attach provided post skirt to bottom of posts when using Trex Signature posts.

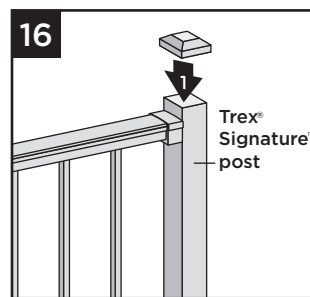

16

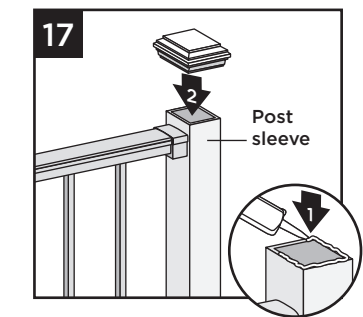

17

16. Attach post caps to Trex Signature posts (use of **rubber mallet** may be required for secure attachment).

17. Attach post caps to post sleeves using external grade PVC construction adhesive (apply adhesive on the inside self-centering/corner tabs).

18. For crossover post configuration, attach crossover post cap to crossover post.

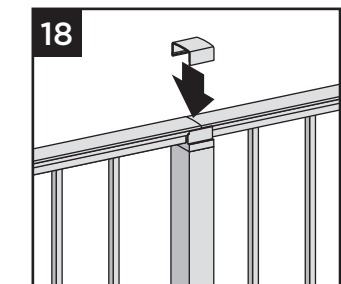

18



HORIZONTAL ROD RAILING

TREX SIGNATURE®

NOTES:

- » Adjust drill power to lowest setting that will drive screw. **DO NOT OVER TORQUE 316 STAINLESS STEEL STAINLESS FASTENERS.**
- » **NEVER** use impact tools on 316 Stainless Steel Fasteners.
- » Be careful inserting rods through intermediate vertical supports. Lay pieces on a flat, solid surface and insert as straight as possible to prevent scratching.
- » When marking lines on bottom rail, do not make a mark wider than 1" or it will be visible after installation.
- » **TOP AND BOTTOM RAILS ARE DIFFERENT LENGTHS, TO ACCOMMODATE THE INSTALLATION OF CROSSOVER POST APPLICATIONS.**
- » **ALL ROD RAILS OVER 6' WILL REQUIRE THE USE OF A FOOT BLOCK, THUS THESE RAILING SPANS MUST BE INSTALLED OVER THE DECKING FRAME OR ON INSIDE OF RIM JOIST.**

PARTS

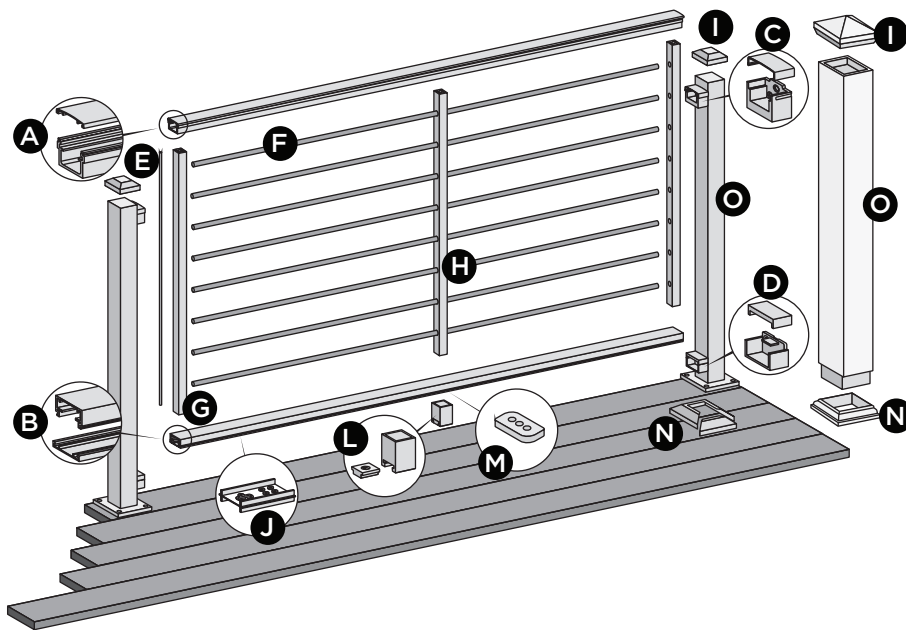

TOOLS NEEDED

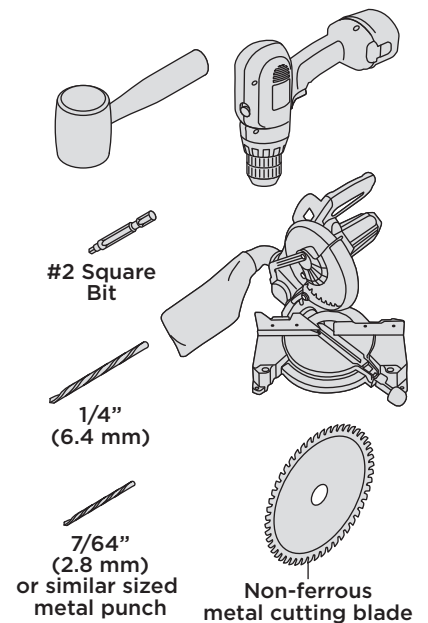

- A. Trex Signature top rail and crowned cover
 - 6' (actual length 73-1/2" [1867 mm])
 - 8' (actual length 97-1/2" [2477 mm])
- B. Trex Signature bottom rail and flat cover
 - 6' (actual length 71-1/2" [181.6 cm])
 - 8' (actual length 95-1/2" [242.6 cm])
- C. Trex Signature upper rail bracket and cover
- D. Trex Signature lower rail bracket and cover
- E. Anti-rattle strip
- F. Rod
- G. End vertical support
- H. Intermediate vertical support
 - Note:** 1 for 6' span/2 for 8' span
- I. Trex Signature post cap or post sleeve cap**
- J. Template
- L. Trex Signature foot block****

- M. HZ spacer
- N. Trex Signature post skirt or post sleeve skirt**
- O. Trex Signature post
 - 36" (actual length 37" [94.0 cm])
 - 42" (actual length 43" [109.2 cm])
 - or Trex 4" x 4" post sleeve**
 - 36" (actual length 40" [102 cm])
 - 42" (actual length 46" [117 cm])

** Item not included in Trex Signature Railing kits. Both 4" x 4" (10.2 cm x 10.2 cm) and 6" x 6" (15.2 cm x 15.2 cm) post sleeves are designed to fit over 4" x 4" pressure-treated post.

*** For 8' Rail Sections only - RODRAILSTIFFENER (included with kit), not shown above

****Foot block required for all spans greater than 6'

TREX SIGNATURE® HORIZONTAL ROD RAILING

RAILING CONFIGURATIONS

Note: See specific installation instructions for attachment of Trex post mounts or Trex Joist Mount Posts prior to installing any railing.

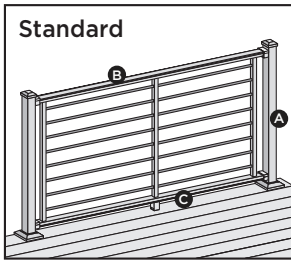

- Cutting posts/post sleeves is **NOT** required.
- A. Trex Signature post, pressure-treated post or Trex Post Mounts with Trex post sleeves, or Trex Joist Mount Posts
 - B. Trex Signature top rail
 - C. Trex Signature bottom rail
- See page 135 for "How to Install Standard Rod Railing".

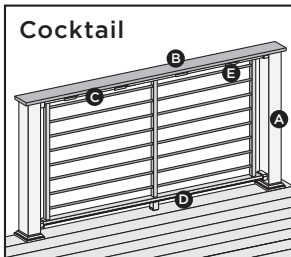

- Post sleeves will need to be cut.
- A. Pressure-treated post with Trex post sleeve
- NOTE:** » Only for use with 4" x 4" (102 mm x 102 mm) post sleeve.
 » Trex Signature Posts, Trex Post Mounts or Joist Mount Posts cannot be used with Trex Signature Cocktail design.
- B. Deck board top rail. **NOTE:** Enhance cannot be used.
 - C. Trex Signature top rail
 - D. Trex Signature bottom rail
 - E. Trex Signature Cocktail Rail Bracket**
- See page 139 for "How to Install Rod Rail Cocktail Railing".

POST SLEEVES WILL NEED TO BE CUT

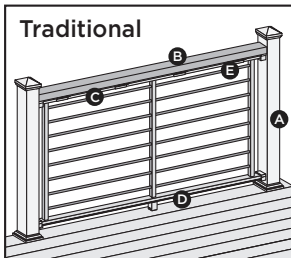

- Cutting posts/post sleeves is Not required.
- A. Pressure-treated post, Trex Post Mounts or Trex Joist Mount Post WITH Trex post sleeves.
- NOTE:** » Trex Signature Posts or Trex Signature Joist Mount Posts cannot be used.
- B. 2 x 4 lateral top rail
 - C. Trex Signature top rail
 - D. Trex Signature bottom rail
 - E. Trex Signature Cocktail Rail Bracket**
- See page 141 for "How to Install Rod Rail Traditional Railing".

» **NOTES:** For post installations refer to page 80.

** Trex Signature Cocktail Rail brackets (sold separately) are for use with either Trex Rod Rail Traditional or Trex Rod Rail Cocktail designs. For a 6' section, use 4 brackets and screws provided, for 8' section, use 5 brackets and screws provided.

BRACKET HARDWARE - HORIZONTAL APPLICATIONS (INCLUDING HORIZONTAL SWIVEL BRACKETS) TREX SIGNATURE®

HORIZONTAL RAILING HARDWARE

- AA. Lower rail bracket with tab or tabless bracket (2 options)
- BB. Lower rail bracket cover
- CC. Upper rail bracket cover
- DD. Upper rail bracket

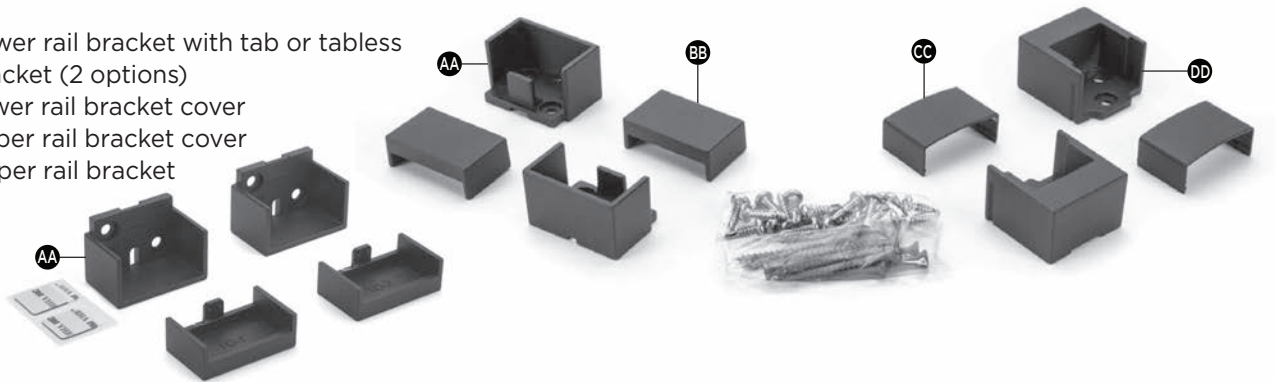

FOOT BLOCK COMPONENTS

- EE. Foot block base
- FF. Foot block support

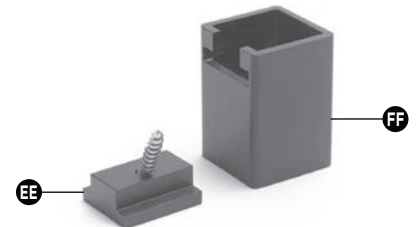

HORIZONTAL SWIVEL HARDWARE

- GG. Swivel base
- HH. Horizontal swivel bracket top rail
- II. Horizontal swivel bracket top rail cover
- JJ. Horizontal swivel bracket bottom rail cover
- KK. Horizontal swivel bracket bottom rail with tab or tabless bracket (2 options)
- LL. Swivel base cover

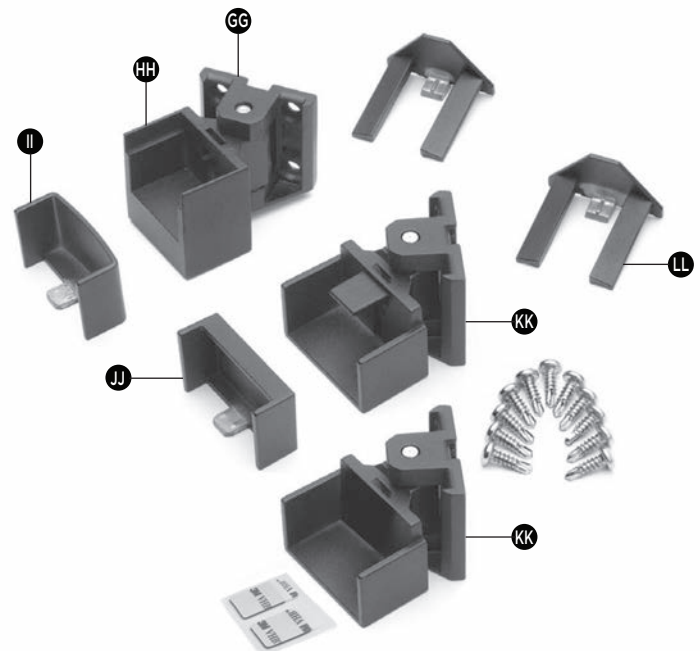

HOW TO INSTALL HORIZONTAL ROD RAILING BRACKETS

TREX SIGNATURE®

Attach Brackets Using Trex Signature Posts

TIP: Use a clamp to help hold brackets in place while fastening with screws.

1. Measure 1-3/8" (3.5 cm) from top of post base plate or 1-7/8" (4.8 cm) from decking surface. Mark with light line.

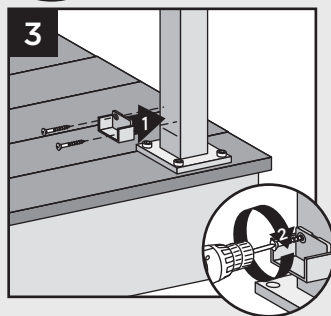
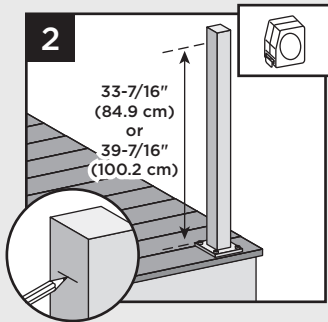
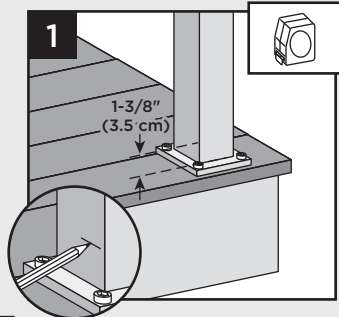

2. Measure up from post base plate 33-7/16" (84.9 cm) for 36" (92 cm) rail height or 39-7/16" (100.2 cm) for 42" (107 cm) rail height. Mark with light line.

NOTE: If measuring from decking surface, measure up 33-15/16" (86.2 cm) for 36" (92 cm) rail height or 39-15/16" (101.4 cm) for 42" (107 cm) rail height.

3. Center lower bracket on post **above** the marked line and attach using two self-tapping screws (provided).
4. Center upper bracket on post **above** marked line and attach using (3) self-tapping screws (provided).

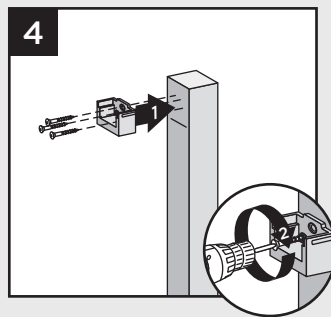

NOTE: Upper bracket is not required on crossover post configuration.

Attach Brackets Using Pressure-Treated Posts and Post Sleeves

TIP: Use a clamp to help hold brackets in place while fastening with screws.

1. Measure 1-7/8" (4.8 cm) up from deck surface to bottom of bracket. Slide skirt up to allow for proper measurement. Mark with light line.

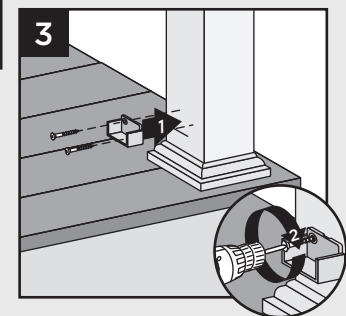
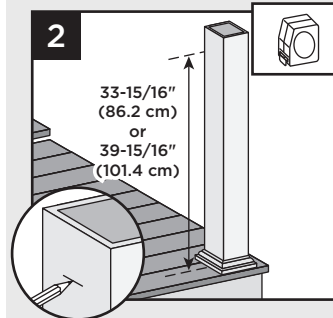
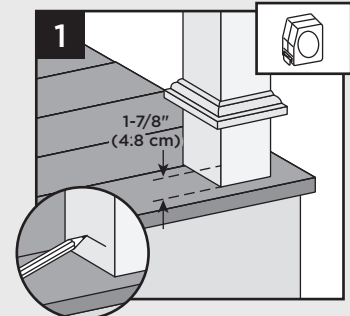

2. Measure up from decking surface 33-15/16" (86.2 cm) for 36" (92 cm) rail height or 39-15/16" (101.4 cm) for 42" (107 cm) rail height. Mark with light line.

NOTE: Push skirt back down onto surface of decking **BEFORE ATTACHING BRACKETS.**

3. Center lower bracket on post **above** the marked line and attach using two 2" (51 mm) wood screws (provided).
4. Center upper bracket on post **above** marked line and attach using three 2" (51 cm) wood screws (provided).

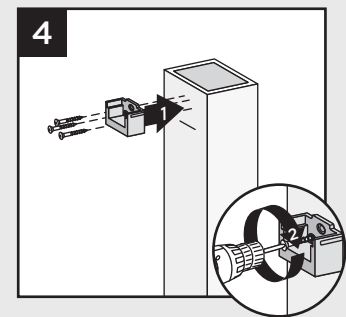

HOW TO INSTALL HORIZONTAL ROD RAILING SWIVEL BRACKETS

TREX SIGNATURE®

Attach Swivel Brackets Base Using Trex Signature Posts

TIP: Use a clamp to help hold brackets in place while fastening with screws.

1. Measure 1-3/8" (3.5 cm) from top of post base plate or 1-7/8" (4.8 cm) from decking surface. Mark with light line.

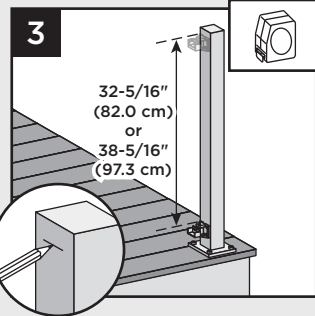
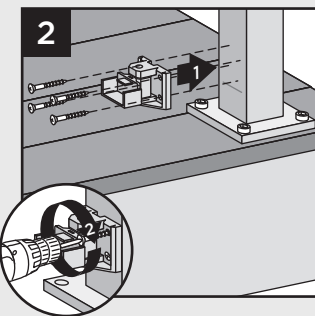
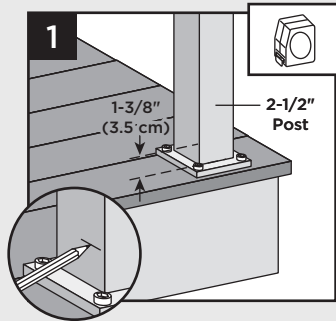

2. Center lower bracket on post **above** the marked line and attach using four self-tapping screws (*provided*).
3. Measure up 32-5/16" (82.0 cm) for 36" (91.4 cm) tall railing or 38-5/16" (97.3 cm) for 42" (106.7 cm) tall railing from top of lower rail bracket. Mark with a light line.
4. Center upper bracket on post **below** marked line and attach using four self-tapping screws (*provided*).

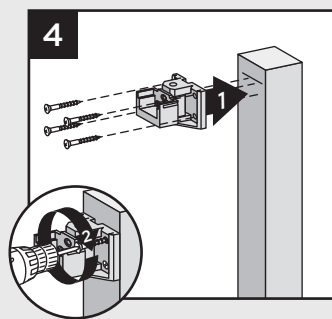

NOTE: Upper bracket is not required on crossover post configuration.

Attach Swivel Brackets Using Pressure-treated Posts and Post Sleeves

TIP: Use a clamp to help hold brackets in place while fastening with screws

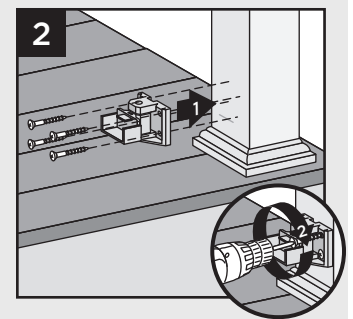
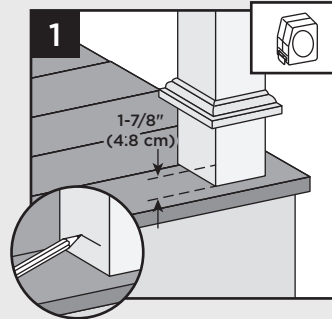

1. Measure 1-7/8" (4.8 cm) up from deck surface to bottom of bracket. Slide skirt up to allow for proper measurement, then push skirt back down onto surface of decking **BEFORE ATTACHING BRACKET**. Mark with light line.
2. Center lower bracket on post **above** the marked line and attach using four 2" (5.1 cm) wood screws (*provided*).

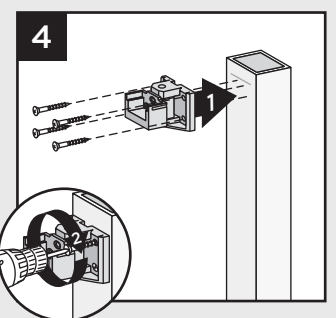
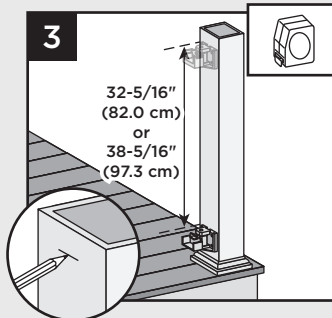

3. Measure up 32-5/16" (82.0 cm) for 36" (91.4 cm) tall railing or 38-5/16" (97.3 cm) for 42" (106.7 cm) tall railing from top of lower rail bracket. Mark with a light line.
4. Center upper bracket on post **below** marked line and attach using four 2" (5.1 cm) wood screws (*provided*).

HOW TO INSTALL ROD RAIL STANDARD RAILING

TREX SIGNATURE®

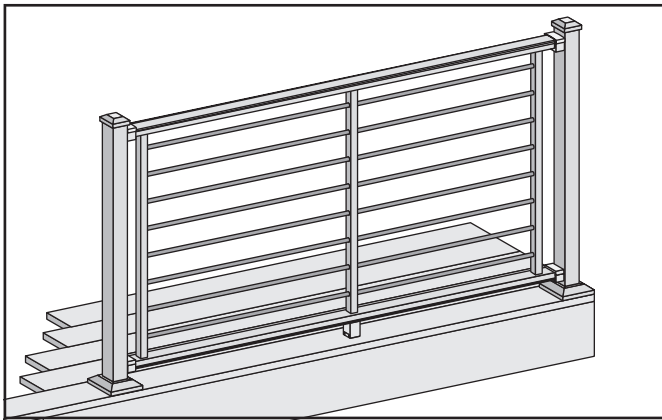

1. Prepare a solid work surface area (plywood, deck surface, etc.).

How to Measure Bottom and Top Railings (When Required)

2. For Full Span Post to Post Applications - only top rail will need to be cut.
3. For Full Span Crossover to Crossover post Applications - no rails have to be cut, HOWEVER the location of the HZ Template on the top rail will need to be adjusted in 3/4" on each side of top rail to allow for proper placement of vertical supports.

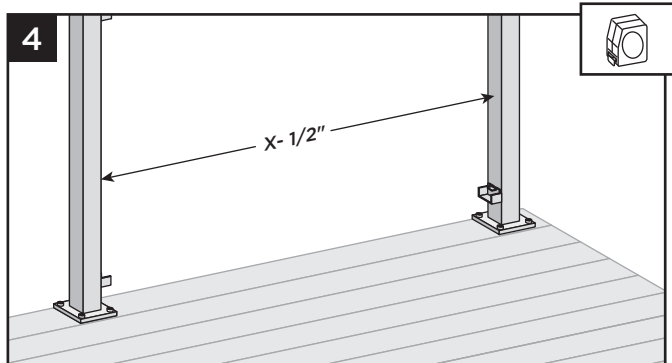

4. Measure distance between posts (X), and subtract 1/2" for bracket clearance.

If installing crossover post configurations adjust top rail length: $X + 3/4"$ if using one crossover post, or $X + 1-1/2"$ if using two crossover posts.

If using swivel brackets, measure distance between brackets and cut railings to this distance.

Cutting Railings and Covers

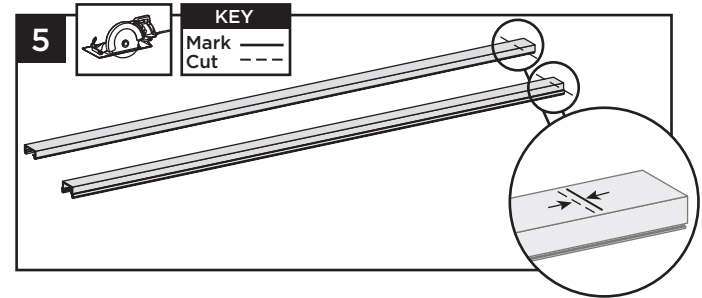

5. Cut both bottom and top rail to length as determined above.

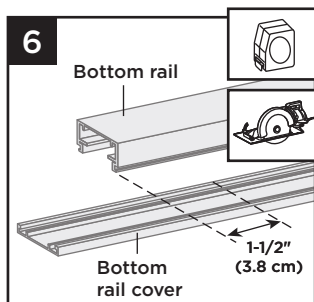

6. Mark and cut bottom rail cover 1-1/2" (3.8 cm) shorter than bottom rail.

NOTE: If using the tabless bracket cutting bottom rail cover is not required.

7. Mark and cut top rail cover same length as top rail for all top rail configurations.

Locating Vertical Holes on Bottom and Top Rails

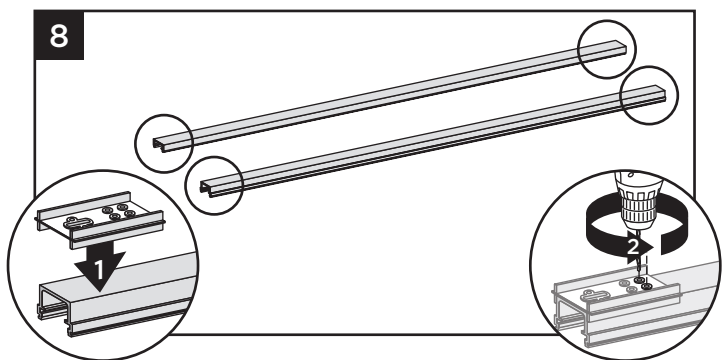

8. Place HZ template at end of top and bottom rails. Pre-drill pilot holes (using a 7/64" bit or small punch) at locations.

NOTES:

- » Template is labeled for the type of bracket used.
- » Pilot holes will be drilled out larger in a later step.
- » For Compound Swivel Brackets, set the rail in the bracket and mark 3.75" from the post.

HOW TO INSTALL ROD RAIL STANDARD RAILING/CONTINUED

TREX SIGNATURE®

6' Rail Spans or Shorter

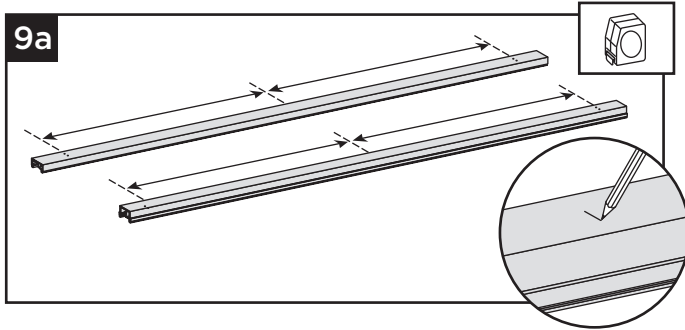

9a. Measure the distance between the vertical end holes on **both top and bottom rails**. Mark the center.

IMPORTANT NOTE: DO NOT mark the line across the entire width of the bottom rail, as it will be visible after install. Maximum recommended line width is 1".

Over 6' Rail Spans

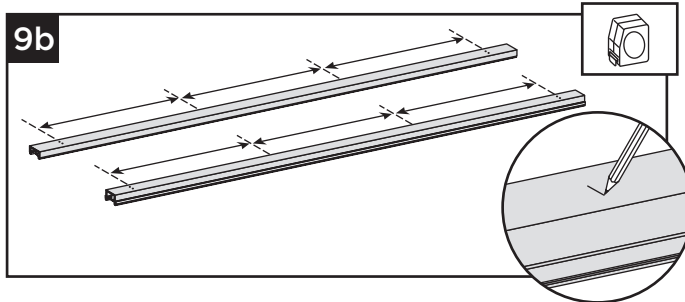

9b. Measure the distance between the vertical end holes on **both top and bottom rails**. Divide the distance into thirds and make two marks on top and bottom rails.

NOTE: Maximum unsupported rod span is 32.25

Locating and Drilling Midspan Holes

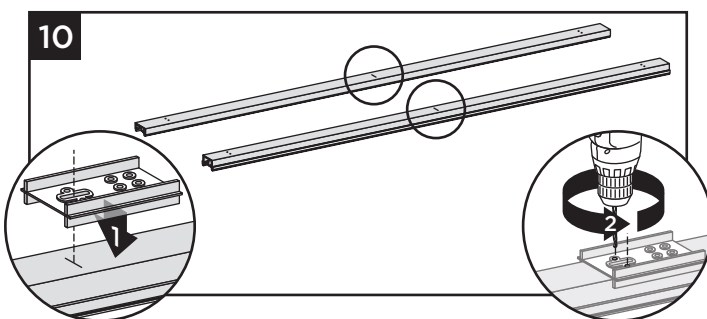

10. Using the slot on the HZ template, locate marked line and drill two 7/64" pilot holes (or mark with a punch).

NOTE: Pilot holes will be drilled out larger in next step.

11. Using pilot holes (or marks), drill 1/4" holes for all vertical supports in both top and bottom rails.

NOTE: Clean any burrs from edges of holes to ensure good fit on both sides.

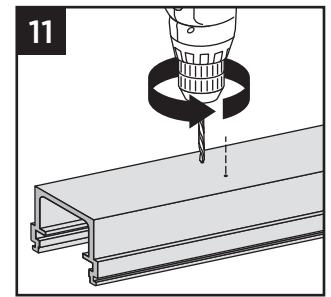

Cutting Rods to Length (When Required)

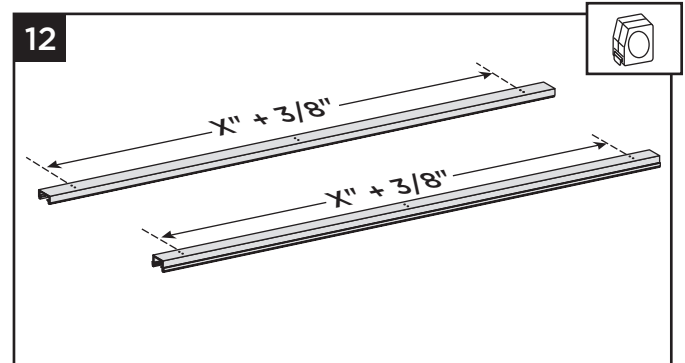

12. Measure the distance between the end (outer) holes (X") on top or bottom rail and add 3/8" to this measurement.

NOTE: If installed at exact spans, rods do not have to be cut.

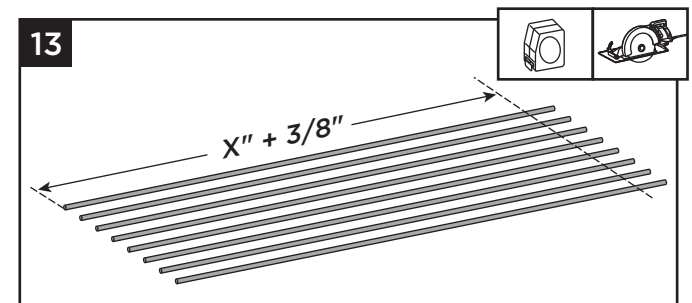

13. Cut rods to the length measured in previous step.

HOW TO INSTALL ROD RAIL STANDARD RAILING/CONTINUED

TREX SIGNATURE®

Vertical and Rod Assembly

14. Insert anti-rattle strips into the vertical supports.

NOTE: There are two anti-rattle strips for each support which can only be inserted in one side.

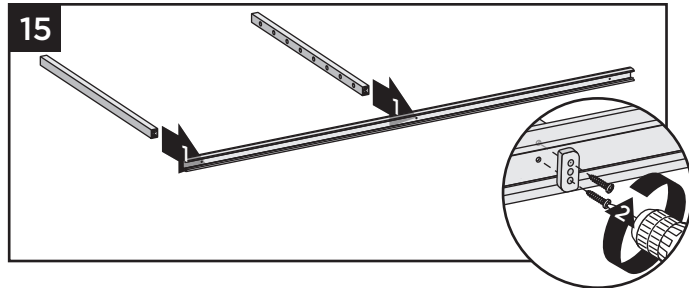
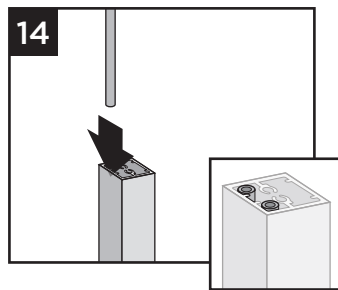

15. Attach **one** end vertical and **all** intermediate verticals to bottom rail using HZ spacer and screws provided.

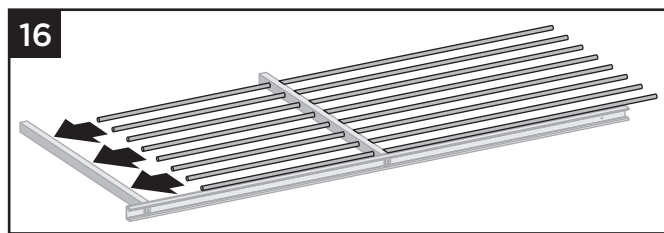

16. Slide all rods through intermediate supports and into end vertical support.

NOTE: When inserting rods through intermediate supports, keep rods straight to avoid scratching

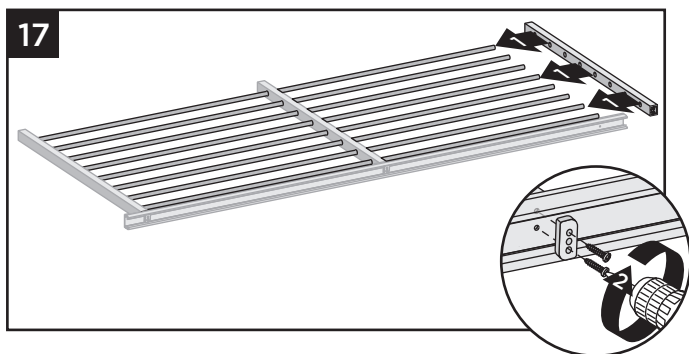

17. Slide end vertical onto rods and attach to bottom rail using HZ spacer and screws provided.

Installing Bottom Rail Cover and Top Rail to Verticals

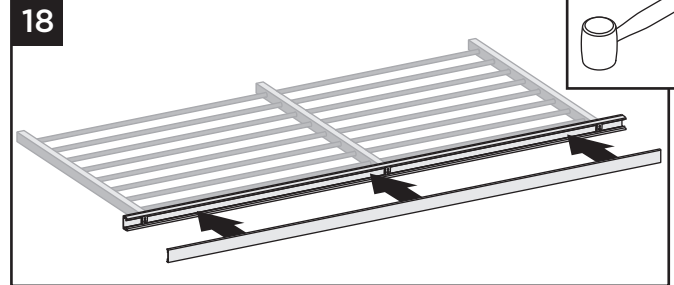

18. Using a mallet, install bottom rail cover onto bottom rail.

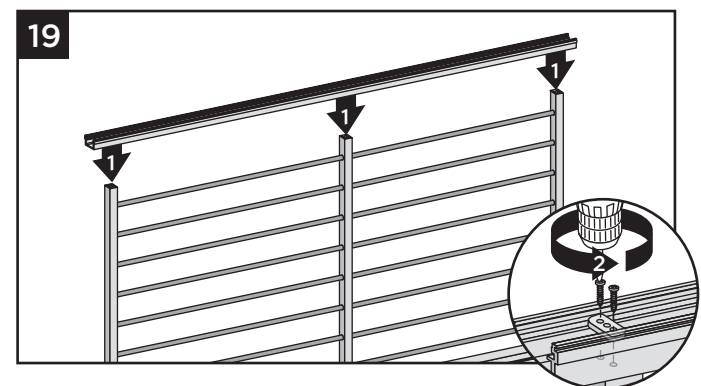

19. Install top rail to all vertical and end supports using HZ spacer and screws provided.

Attaching Foot Block (when required)

Required **ONLY** for All Clear Span Applications over 6' (1.83 m). Included with 8' (2.44 m) railing kits.

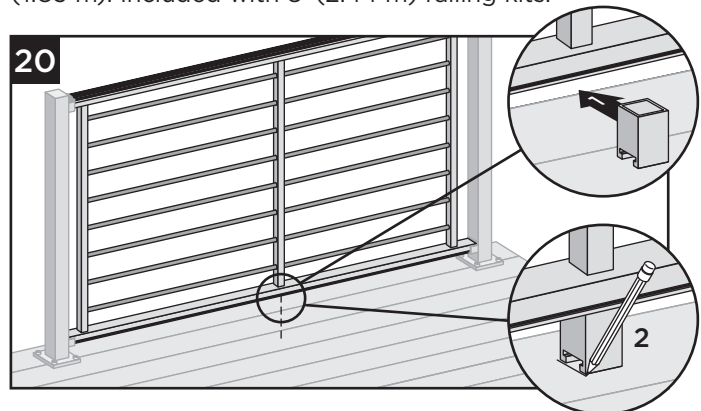

20. Temporarily drop rod rail panel into brackets. To ensure correct location, place foot block under center of bottom panel. Mark to provide placement location of base. Once marked remove panel.

HOW TO INSTALL ROD RAIL STANDARD RAILING/CONTINUED

TREX SIGNATURE®

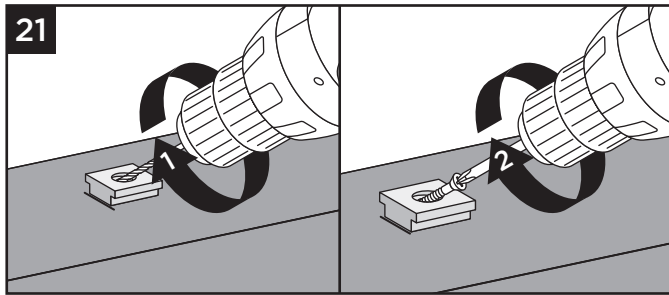

21. Place base (smaller side facing down) on decking surface. Pre-drill using a 3/16" bit. Attach base of foot block using one screw at an angle through base and into decking.

22. After attached, use a rubber mallet along with scrap piece of wood to tap foot block until it locks into place.

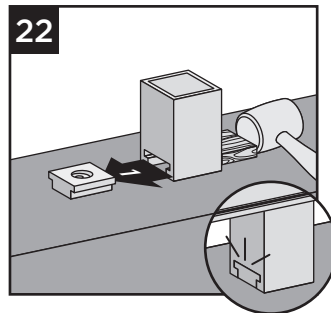

When using Tabless Lower Brackets

23. Place adhesive strips (provided) into bottom rail brackets.

NOTE: Make sure surface is clean and dry.

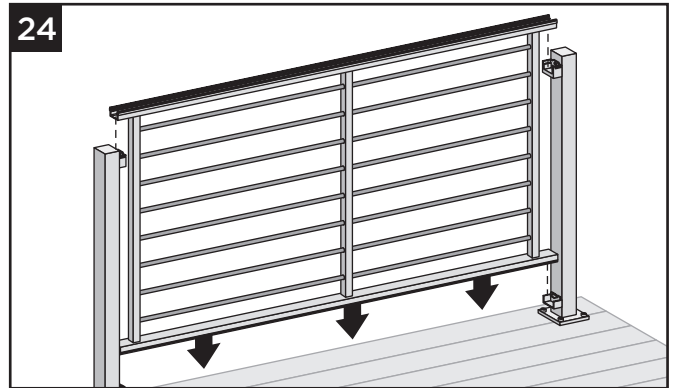
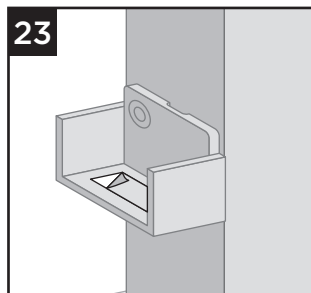

24. Drop assembled rod rail panel into brackets.

Attaching Panel to Brackets

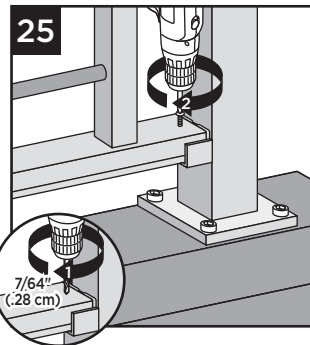

25. If using tabbed lower brackets, attach bottom rail to bottom brackets by using one self-tapping screw (provided) for each bracket. No screws are required if using the tabless lower bracket.

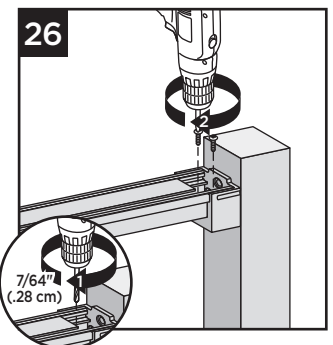

26. Attach top rail to top brackets by using two self-tapping screws (provided) for each bracket.

NOTE: Pre-drilling is required (7/64" [0.28 cm] drill bit) for attachment of railing to bracket.

Inserting Rod Rail Stiffener - For Rail Sections Over 6'

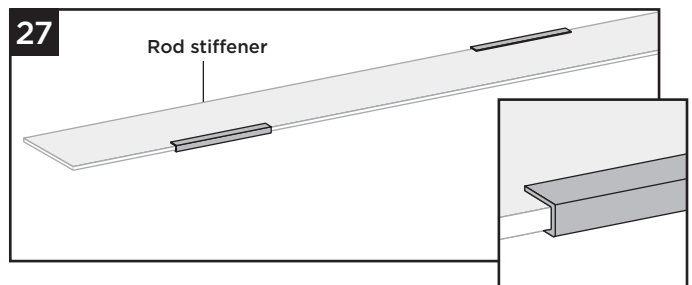

27. Attach tape (qty 6 provided) to alternating sides of the rod stiffener as shown.



HOW TO INSTALL ROD RAIL STANDARD RAILING/CONTINUED TREX SIGNATURE®

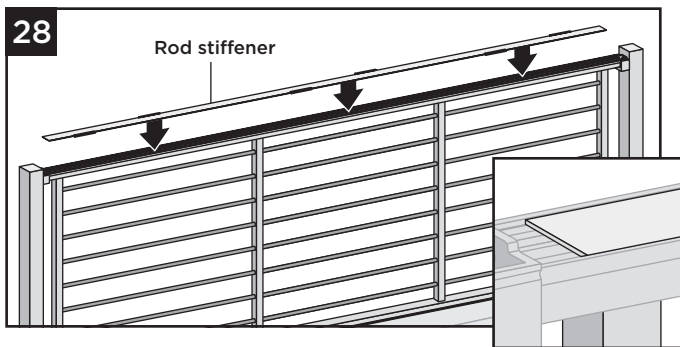

28. Place rod stiffener inside rail channel.

Installing Top Rail Cover

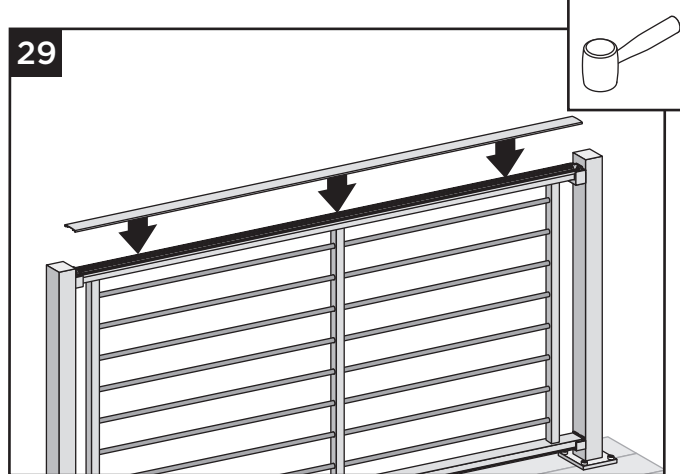

29. Using a mallet, install top rail cover.

Attachment of Bracket Covers, Skirts, and Caps

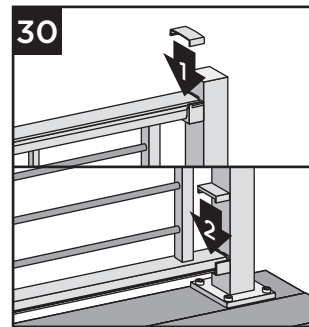

30. Attach corresponding bracket covers over opening in top and bottom rails.

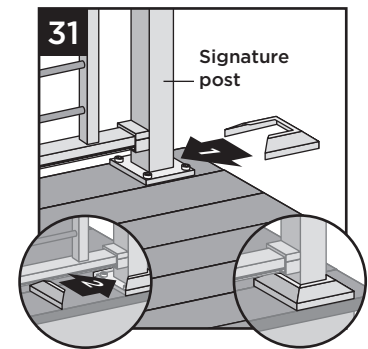

31. Attach provided post skirt to bottom of posts when using Trex Signature posts.

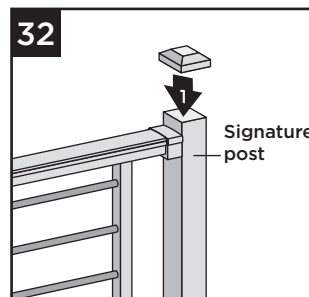

32. Attach post caps to Trex Signature posts. (Use of **rubber mallet** may be required for secure attachment.)

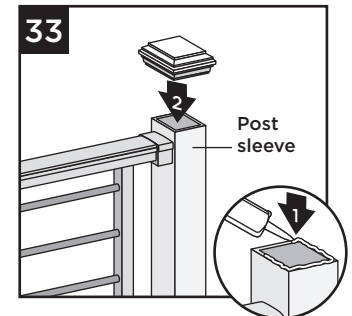

33. Attach post caps to post sleeves using external grade PVC construction adhesive (apply adhesive on the inside self-centering/corner tabs).

HOW TO INSTALL ROD RAIL COCKTAIL RAILING TREX SIGNATURE®

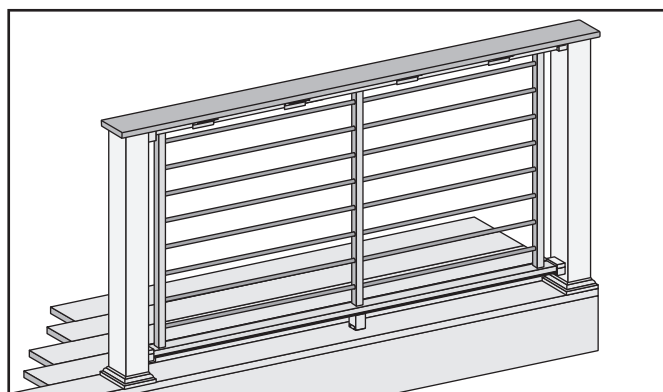

IMPORTANT NOTE:

» **ONLY** for use with pressure treated 4 x 4 post (3.5" nominal square) and 4" x 4" (102 mm x 102 mm) post sleeve. Trex® Signature™ posts, Trex post mounts or joist mount posts cannot be used with Trex® Rod Rail Cocktail railing. Cutting post and post sleeve **ONLY** applies to the Cocktail style railing.



HOW TO INSTALL ROD RAIL COCKTAIL RAILING/CONTINUED

TREX SIGNATURE®

Installing Pressure-treated Posts, Post Sleeves, and Skirts to Use with Rod Rail Cocktail Railing

NOTE: PLEASE REFER TO LOCAL BUILDING CODE REQUIREMENTS PRIOR TO ATTACHING PRESSURE TREATED POSTS. BELOW INSTRUCTIONS ARE GUIDELINES FOR GENERAL REQUIREMENTS.

- 1a. Attach posts using 1/2" (13 mm) carriage bolts.
 - » Minimum joist size is 2" x 8" (51 mm x 203 mm).
 - » Top bolts must be 1" (25 mm) from top of joists.
 - » Bottom bolts must be 5-1/8" (130 mm) from top bolts.

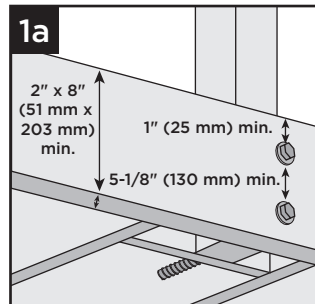

NOTE: Blocking can be added for extra strength.

- 1b. Slide post sleeve skirt over post and down to rest on decking surface. Slide post sleeve over post and position inside post sleeve skirt.

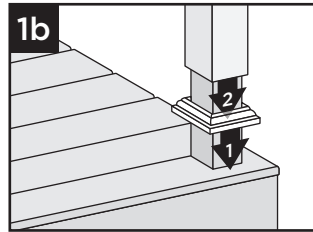

NOTE: Shims can be used to plumb post sleeves.

Cutting Post and Post Sleeve

2. Mark and cut post and post sleeve measuring from deck surface:
 - » 36-1/32" (915 mm) for 36" (914 mm) height.
 - » 42-1/32" (1068 mm) for 42" (1067 mm) height.

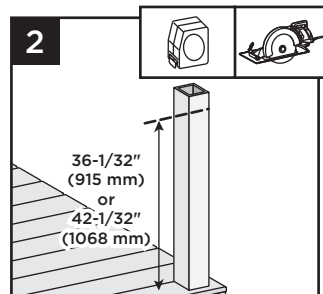

3. Measuring and Cutting Rails and Covers

See instructions on page 135.

4. Locating Vertical Holes on Bottom and Top Rails

See instructions on page 135.

5. Locating and Drilling Midspan Holes

See instructions on page 136.

6. Cutting Rods to Length (when required)

See instructions on page 136.

7. Vertical and Rod Assembly

See instructions on page 137.

8. Installing Bottom Rail Cover and Top Rail to Verticals

See instructions on page 137.

9. Installing Foot Blocks (when required)

See instructions on page 137.

10. Installing Railing to Brackets

See instructions on page 138.

11. Installing Rod Rail Stiffener (when required)

See instructions on page 138.

12. Installing Top Rail Cover

See instructions on page 139.

NOTE: Top Bracket Covers are not attached in this configuration.

Attaching Deck Board to Top Rail

13. Place deck boards (**DO NOT** use Enhance deck boards for top rail) over top rails. Attach boards on each post with Trex-recommended composite screws (quantity of 2 per each post/board end).

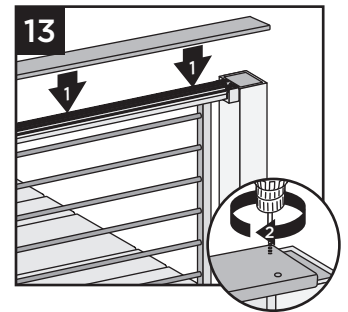

14. Secure boards to top rail using Trex Signature Cocktail Bracket (sold separately). Ensure that there is a bracket at each end of the railing section, then space brackets approximately every 24" and attach with 4 screws provided.

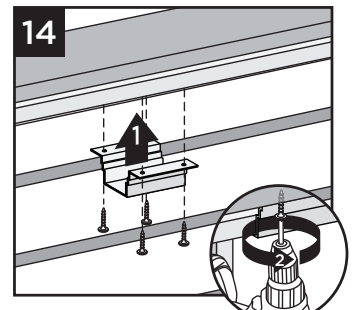

NOTE: Pre-drilling before attachment is recommended.

15. Use scarf cut for posts where two deck boards meet.

NOTES:

- » Leave 1/8" (3 mm) gap between deck boards.
- » Deck boards can overhang end of last post maximum 1/2" (13 mm).

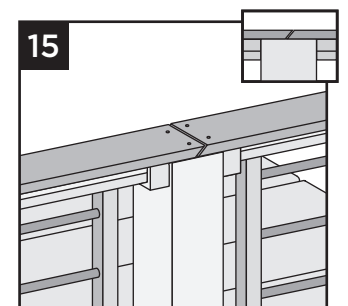

16. Attachment of Bottom Bracket Covers

See instructions on page 139.

HOW TO INSTALL ROD RAIL TRADITIONAL RAILING

TREX SIGNATURE®

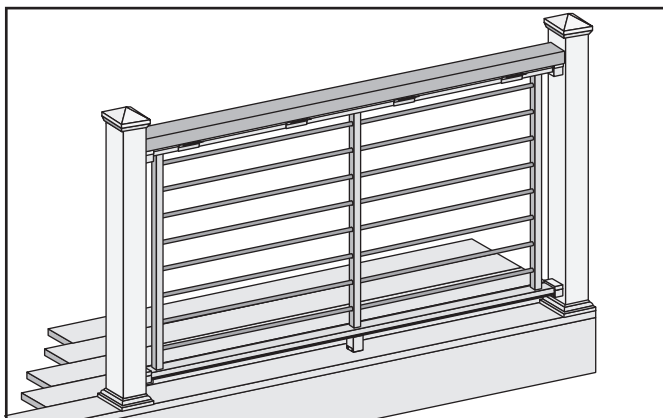

Important: ONLY use with Pressure-treated post, Trex Post Mounts or Trex Joist Mount Post WITH Trex post sleeves. Trex Signature Posts and Joist Mount Posts cannot be used with Rod Rail Traditional.

1. Installing Posts, Post Sleeve Skirts and Post Sleeves

See instructions on page 80 for pressure treated posts. Refer to detailed Trex Post Mount instructions if using these. Post and Post Sleeves are **NOT CUT** in this installation.

2. Measuring and Cutting Rails and Covers

See instructions on page 135.

3. Locating Vertical Holes on Bottom and Top Rails

See instructions on page 135.

4. Locating and Drilling Midspan Holes

See instructions on page 136.

5. Cutting Rods to Length (when required)

See instructions on page 136.

6. Vertical and Rod Assembly

See instructions on page 137.

7. Installing Bottom Rail Cover and Top Rail to Verticals

See instructions on page 137.

8. Installing Foot Blocks (when required)

See instructions on page 137.

9. Installing Railing Panel to Brackets

See instructions on page 138.

10. Installing Rod Rail Stiffener (when required)

See instructions on page 138.

11. Installing Top Rail Cover

See instructions on page 139.

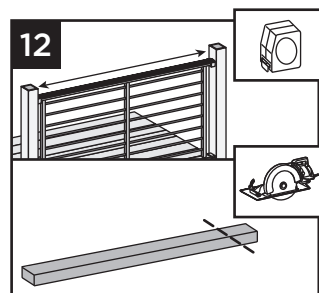

Attaching

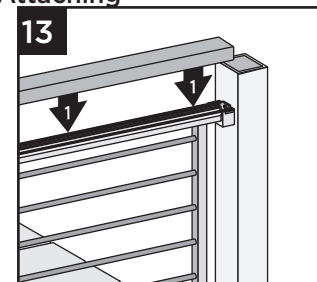

2 x 4 to Top Rail

12. Measure between posts and cut 2 x 4 to length.

13. Place 2 x 4 on Trex® Signature top rail.

14. Secure 2 x 4 to top rail using Trex® Signature Cocktail Bracket (sold separately). Ensure that there is a bracket at each end of the railing section, then space brackets approximately every 24" and attach with 4 screws provided.

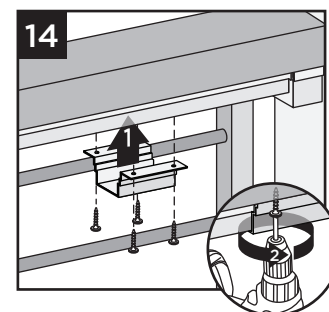

NOTE: Pre-drilling before attachment is recommended.

15. Pre-drill and toenail 2-1/2" (6.4 cm) approved deck screw at each end of 2 x 4 into post on back side of rail (side not facing decking).

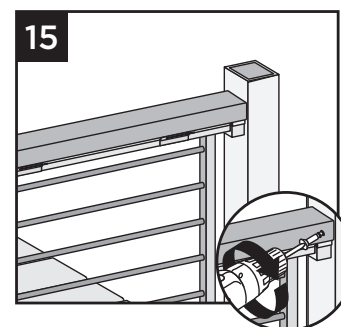

16. Attachment of Bottom Rail Bracket Covers and Caps

See instructions on page 139.

ROD RAIL STAIR RAILING BRACKET HARDWARE (INCLUDING STAIR SWIVEL BRACKETS AND STAIR CROSSOVER BRACKET) TREX SIGNATURE®

FIXED BRACKET - STAIR HARDWARE

- AA. Bottom Stair Bracket and Cover - Lower Rail
- BB. Top Stair Bracket and Cover - Lower Rail
- CC. Fastener Pack
- DD. Bottom Stair Bracket and Cover - Upper Rail
- EE. Top Stair Bracket and Cover - Upper Rail

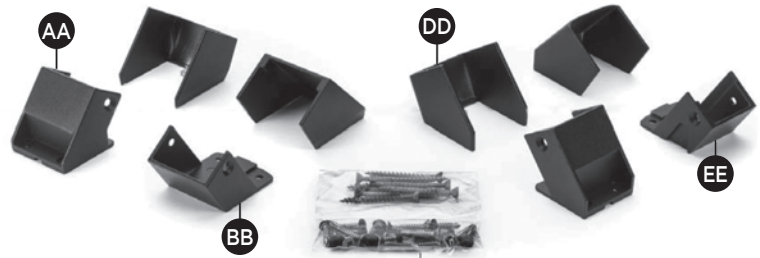

SWIVEL BRACKET - STAIR HARDWARE

- FF. Swivel Top Rail Bracket and Cover - Stair
- GG. Swivel Bottom Rail Bracket and Cover - Stair
- HH. Fastener Covers
- II. Fastener Pack

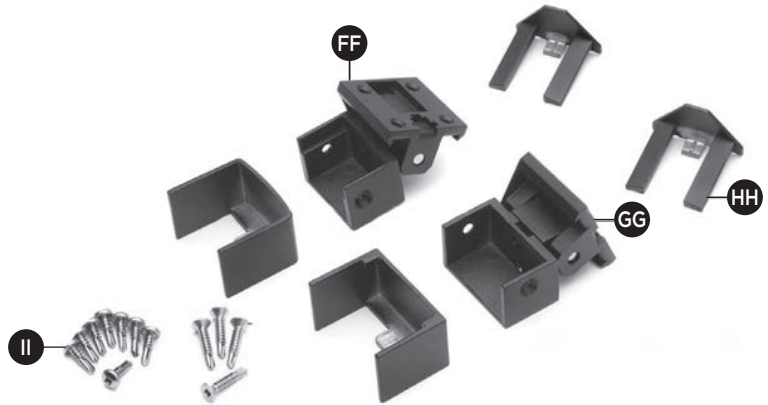

SWIVEL CROSSOVER BRACKET KIT - STAIR HARDWARE

- NN. Swivel Crossover Bracket - Stair
- OO. Post-to-Bracket Fasteners

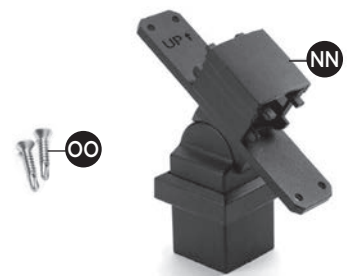

HOW TO INSTALL ROD RAIL STAIR POSTS

TREX SIGNATURE®

TOOLS NEEDED

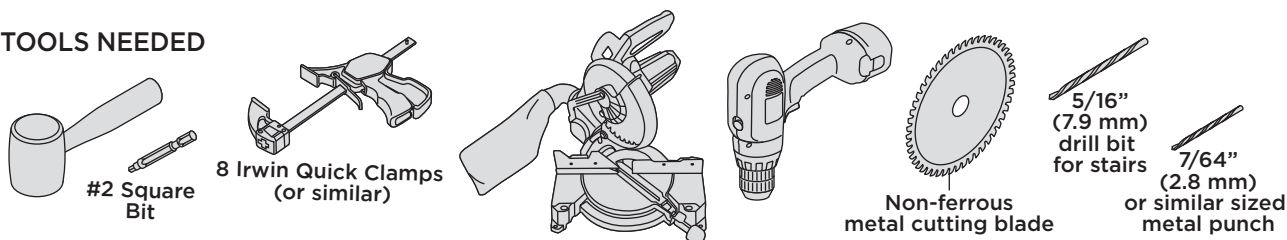

IMPORTANT NOTES:

- » FOR A 6' OR 8' STAIR RAIL, POST TO POST SPAN WILL BE LESS THAN 6' OR 8'. PRIOR TO INSTALLING STAIR POSTS CALCULATE POST TO POST SPAN USING A MAXIMUM STAIR RAIL LENGTH REQUIRED AND THE ANGLE (32°-37°) AT WHICH THE STAIR RAILS WILL BE INSTALLED. DO NOT INSTALL STAIR POSTS AT 6' OR 8' SPAN, AS STAIR RAILINGS WILL THEN BE TOO SHORT.
- » TREX SIGNATURE POSTS CANNOT BE USED WITH TREX ROD RAIL TRADITIONAL OR TREX ROD RAIL COCKTAIL STAIR DESIGNS, ONLY PRESSURE-TREATED POST/POST SLEEVES CAN BE USED. REFER TO DETAILED INSTRUCTIONS FOR MORE INFORMATION.
- » All Trex Rod Rail stair installations require the use of 53" (134.6 CM) stair post, measured and cut to appropriate length if required.
- » If crossover stair post is required, use stair post (again cut to appropriate length if required) and use swivel crossover bracket.
- » Trex Signature Stair fixed brackets are designed to work only with stair slopes of 32°-37°.
- » Foot blocks are required ONLY for All Clear Span Applications over 6' (1.83 m) thus these stair railing spans must be installed over the decking frame or on inside of rim joist. Signature Stair Foot blocks are sold separately.

Installing Standard Trex Signature Stair Posts, Trex Signature Stair Crossover Posts, or Pressure-treated Post, Post Sleeves and Skirts

1. Make sure 53" (135.6 cm) posts are used for all stair posts.

2. If Trex Signature stair posts are used, install at nose of stair tread directly under required blocking. See Trex Signature horizontal post instructions for blocking requirements.

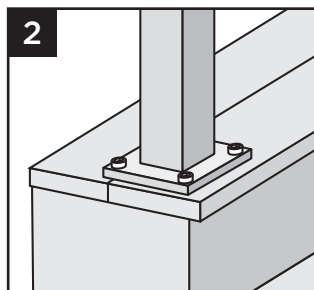

Installing Pressure-Treated Posts

- » PLEASE REFER TO LOCAL BUILDING CODE REQUIREMENTS PRIOR TO ATTACHING PRESSURE TREATED POSTS.
- » PRESSURE TREATED POSTS MUST BE INSTALLED ON INSIDE OF STAIR STRINGER AND AT NOSE OF STAIR TREAD.
- » POST TO POST SPAN WILL BE LESS THAN 6' OR 8'. PRIOR TO INSTALLING POSTS CALCULATE POST TO POST SPAN USING A MAXIMUM RAIL LENGTH REQUIRED AND THE ANGLE (32°-37°) AT WHICH THE RAILS WILL BE INSTALLED. DO NOT INSTALL STAIR POSTS AT 6' OR 8' SPAN, AS STAIR RAILINGS WILL THEN BE TOO SHORT.
- » Attach posts using code approved hardware and also use added blocking.
- » Bolts can be countersunk flush with framing to allow for fascia attachment.
- » In most cases, a post and post sleeve longer than 39" (991 mm) will be needed on the lower section of stair rail to accommodate stair angle.

Note: Blocking can be added for extra strength.

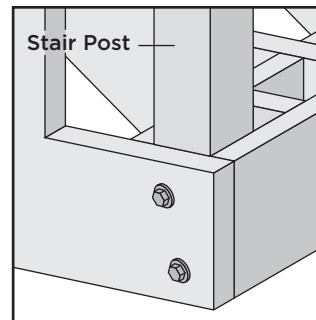

HOW TO INSTALL ROD RAIL STANDARD STAIR RAILING

TREX SIGNATURE®

Cutting Bottom Rail

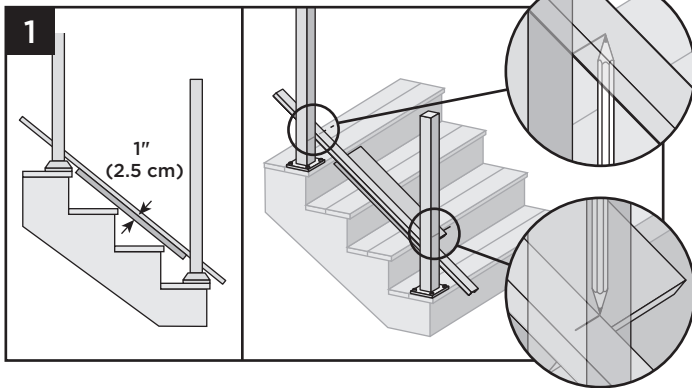

1. Place a 1" deckboard on the nose of the stair tread, then lay the bottom stair rail on top of the deckboard. Use the lower and upper stair post to set the size of the lower stair rail. On **UPPER STAIR POST**, mark from underside of bottom rail. On **LOWER STAIR POST**, mark from top side of bottom rail.

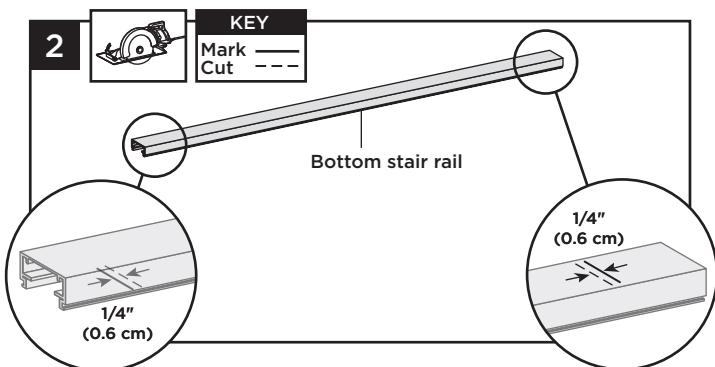

2. Cut each end of the bottom stair rail and bottom rail cover 1/4" (0.6 cm) shorter than the mark on each end to allow for fit into bottom stair rail brackets.

NOTE: Railing does not need to be cut at angle. Brackets are designed to allow for railing to be installed with standard straight cut.

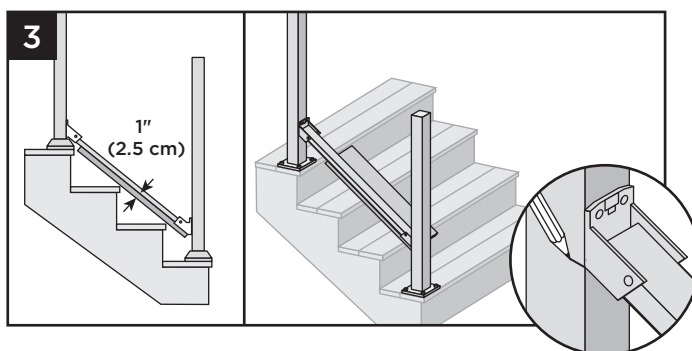

3. With deckboard still on nose of stair tread, place brackets on end of bottom stair rail (DO NOT attach brackets to rail) and mark posts for bracket locations.

Installing Lower Fixed Stair Brackets

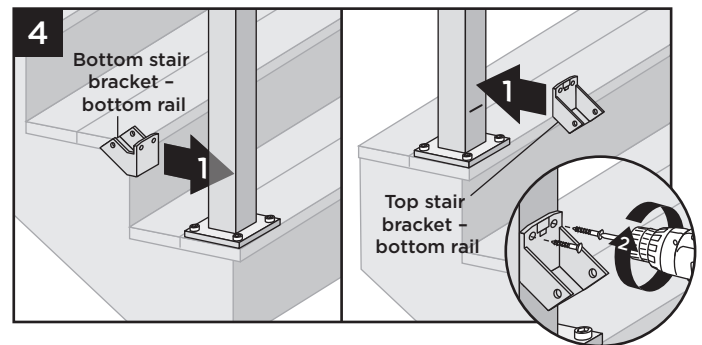

4. Center lower stair bracket on post above the marked line and attach using two self-tapping screws (provided). In some cases it may be difficult to attach the stair bracket on the lower stair post. Recommend using a 90° drill adapter or loosen the post to get access to the lower bracket screw holes.

Installing Upper Fixed Stair Brackets

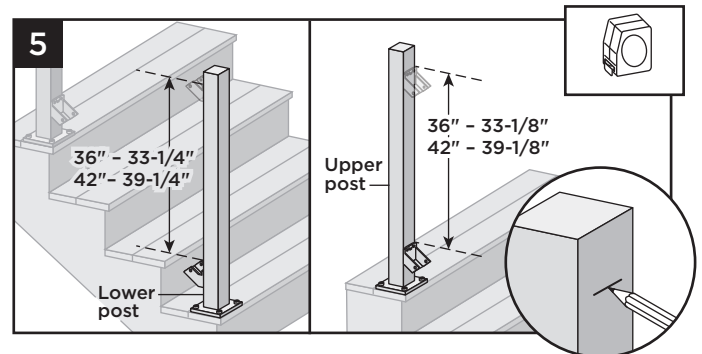

5. **On Lower Post** - From top of lower bracket, measure up and mark with light line (33-1/4" for 36" rail; 39-1/4" for 42" rail).
On Upper Post - From top of lower (upper) bracket, measure up and mark with light line (33-1/8" for 36" rail; 39-1/8" for 42" rail).

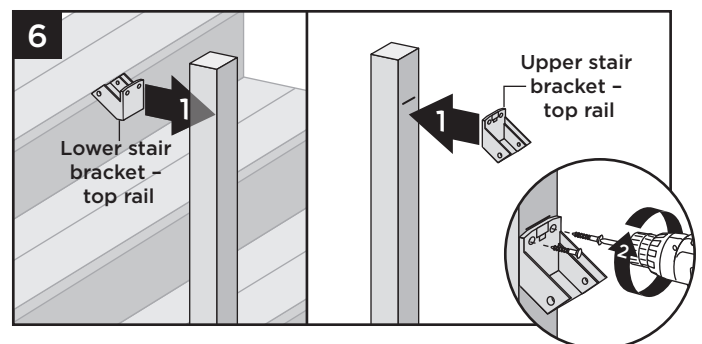

6. Center upper stair brackets on posts **below** the marked lines and attach using two self-tapping screws (provided).



HOW TO INSTALL ROD RAIL STANDARD STAIR RAILING/CONTINUED

TREX SIGNATURE®

7. Set bottom stair rail into bottom stair rail brackets.

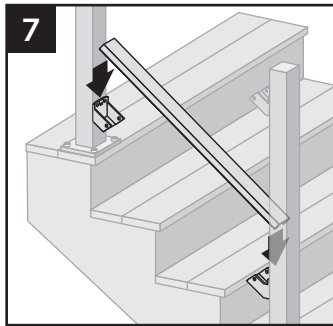

10. Set top stair rail into top stair rail brackets.

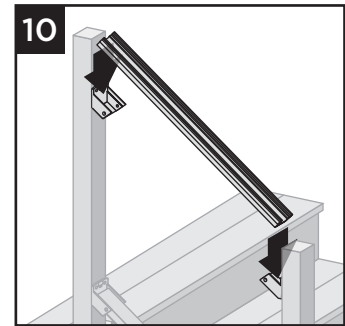

How to Mark, Cut and Place Top Stair Railing

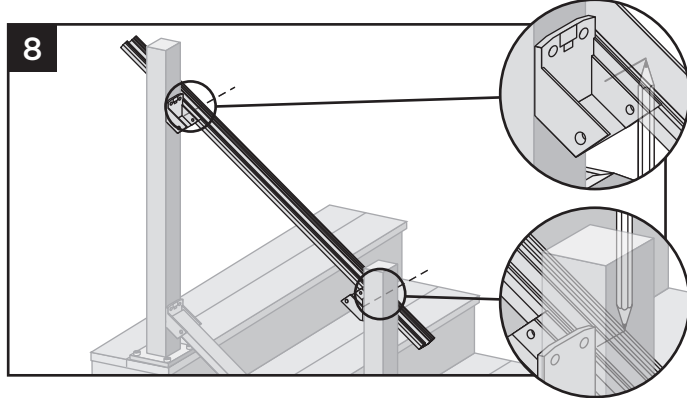

8. Position top rail to side of post. Mark top stair rail at each location stated. On **UPPER STAIR POST**, mark from underside of bottom rail. On **LOWER STAIR POST**, mark from topside of bottom rail.

Measuring and Cutting Rods

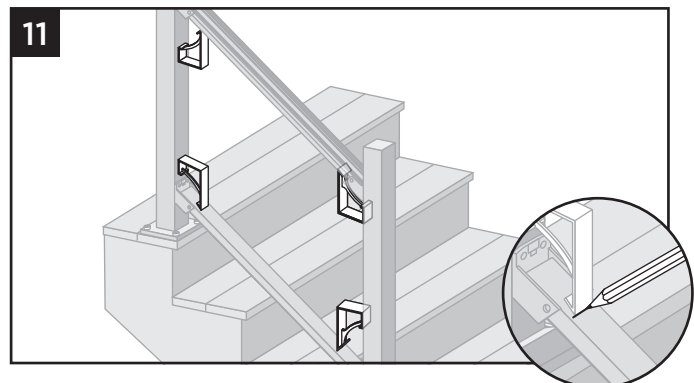

11. Using the long edge of the stair template, mark the location of the end verticals on the upper and lower rails.

NOTE: Mark should only be 1" max length or it will be visible after installation of verticals.

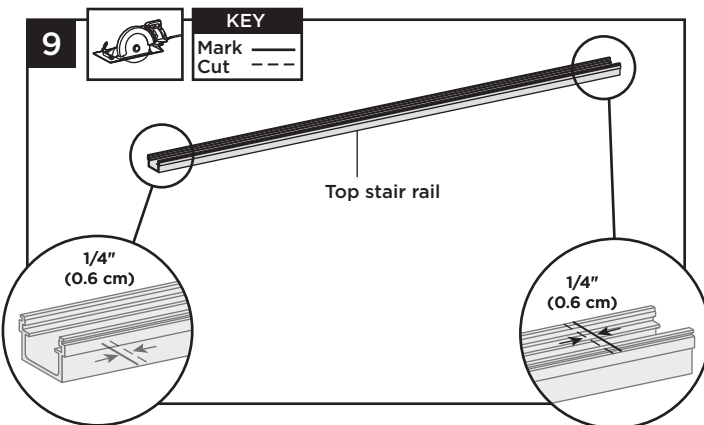

9. Cut each end of top stair rail and top rail cover 1/4" (0.6 cm) shorter than mark to allow for fit into top stair rail bracket.

NOTE: Railing does not need to be cut at angle. Brackets are designed to allow for railing to be installed with standard straight cut. **HOWEVER IF INSTALLING ROD RAIL WITH EITHER COCKTAIL OR TRADITIONAL DESIGN, THE TOP RAIL WILL NEED TO BE CUT ON AN ANGLE.**

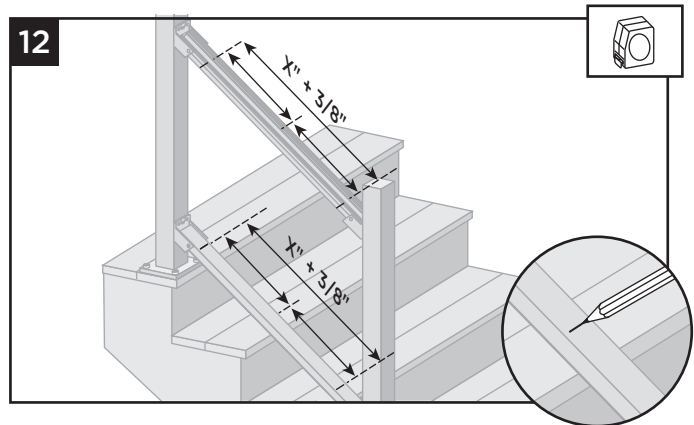

12. Measure and mark the mid-line (6' sections) of the two end marks of the top and bottom rail. Take that measurement and add 3/8" for rod length in next step.

NOTE: For 8' sections divide the distance into thirds and make two marks for the two verticals.

HOW TO INSTALL ROD RAIL STANDARD STAIR RAILING/CONTINUED

TREX SIGNATURE®

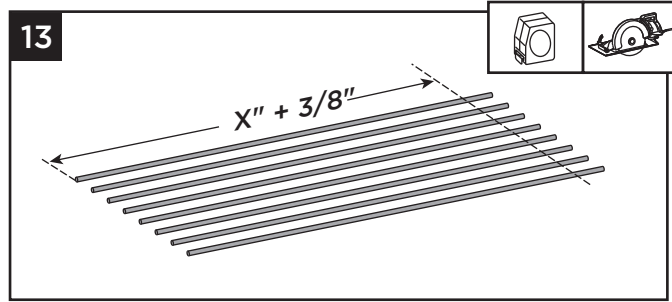

13. Cut rods to the length measured in previous step.

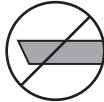

IMPORTANT: DO NOT CUT RODS AT RAIL ANGLE; MAKE 90° CUTS ONLY!

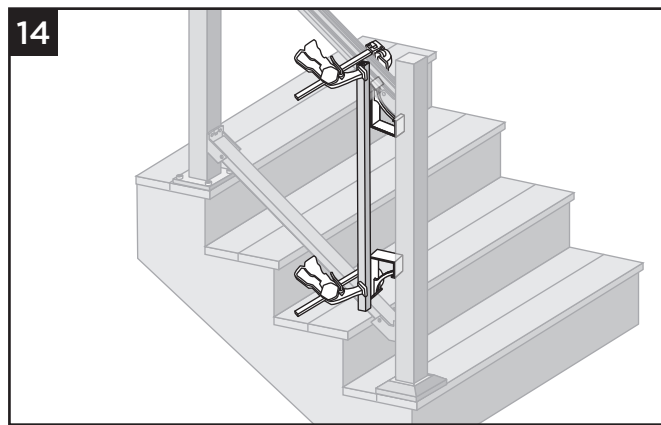

14. Clamp first vertical (lower part of stairs) in place, using width of stair template to position.

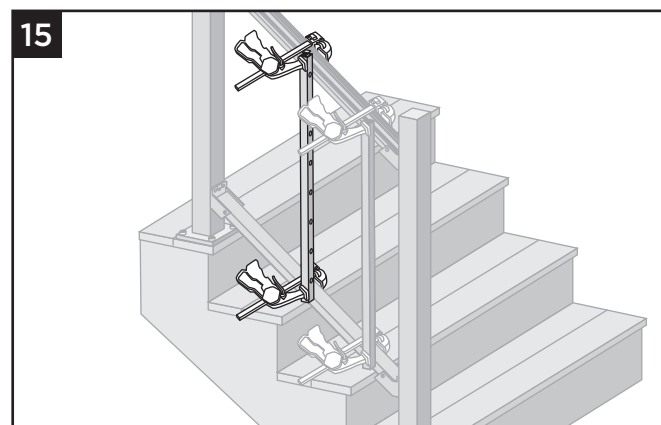

15. Clamp middle vertical(s) in place.

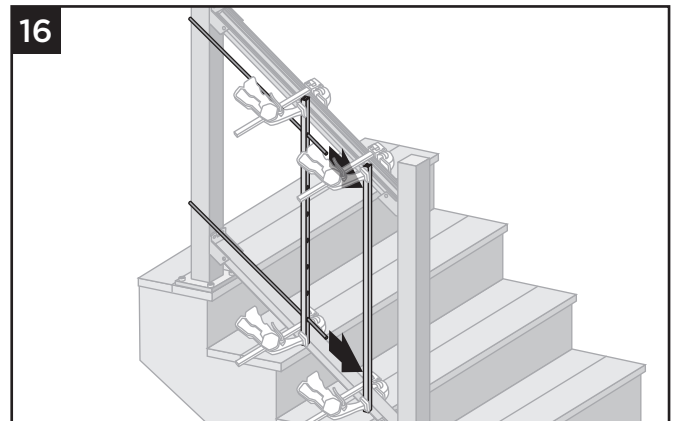

16. Slide a rod into top and bottom of all verticals. Ensure that distance of top rod to top rail and bottom rod to bottom rail are equal.

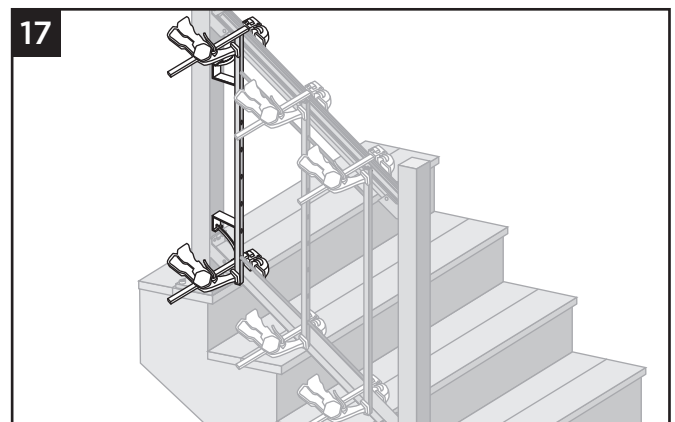

17. Clamp top vertical (upper part of stairs) in place, using width of stair template to position.

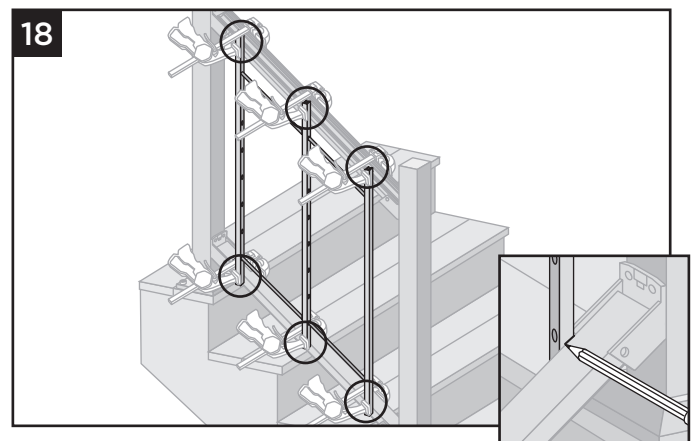

18. Mark angle cuts at top and bottom on all verticals.



HOW TO INSTALL ROD RAIL STANDARD STAIR RAILING/CONTINUED

TREX SIGNATURE®

19. After removing rods and verticals, make angle cuts on top and bottom of verticals following marks from previous step.

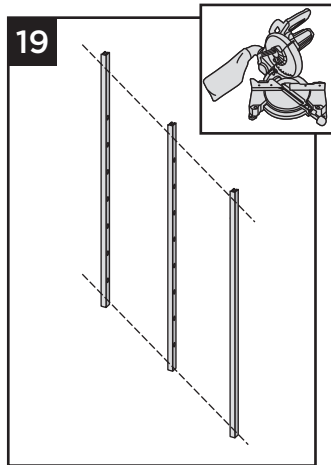

Installing Top and Bottom Rails

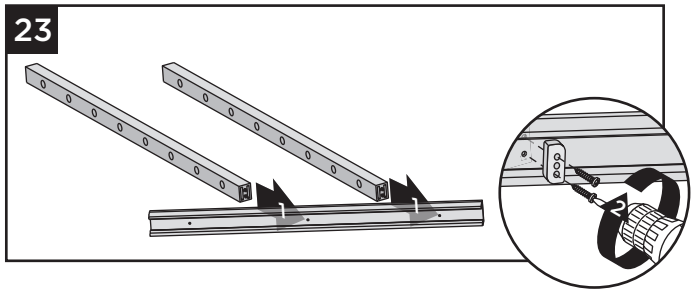

23. Install lowest end vertical and all intermediate verticals to bottom rail using ST Wedge Spacer and screws provided.

Vertical and Rod Assembly

20. Insert anti-rattle strips into the vertical supports.

NOTE: There are two anti-rattle strips for each support which can only be inserted in one side.

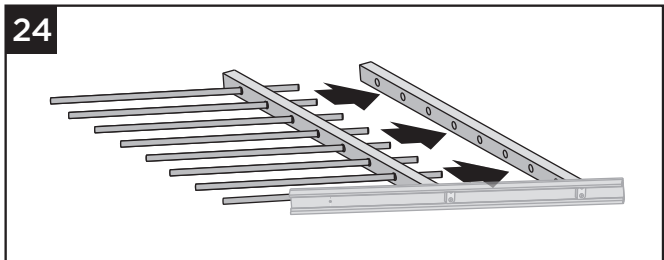
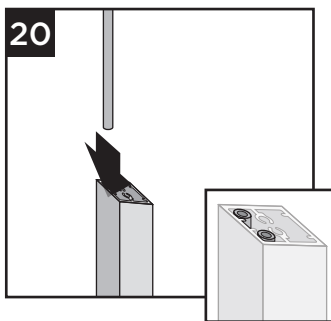

24. Slide rods into lower end and all intermediate verticals.

NOTE: When inserting rods into intermediate supports, keep rods straight to avoid scratching.

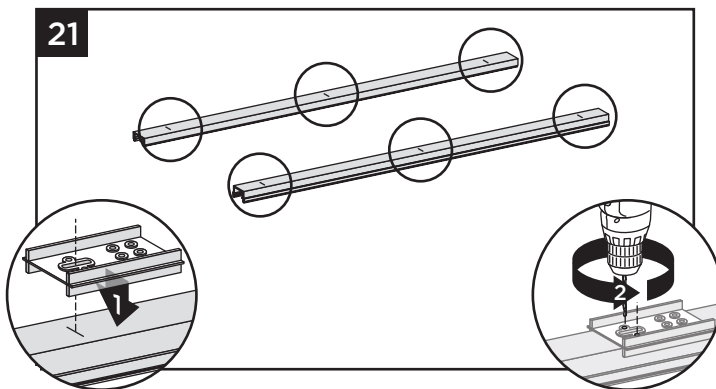

21. Using the slot on the HZ template, locate marked line and drill two 7/64" pilot holes at each mark (or mark with a punch).

NOTE: Pilot holes will be drilled out larger in next step.

22. Using pilot holes (or marks), drill 5/16" holes for all vertical supports in both top and bottom rails.

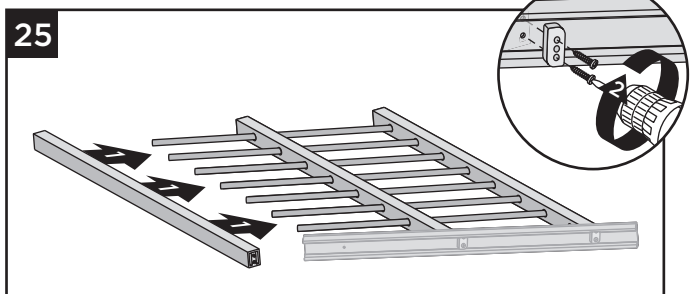
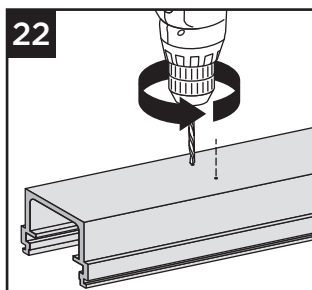

25. Slide upper end vertical onto rods and attach to bottom rail using ST Wedge Spacer and screws provided.

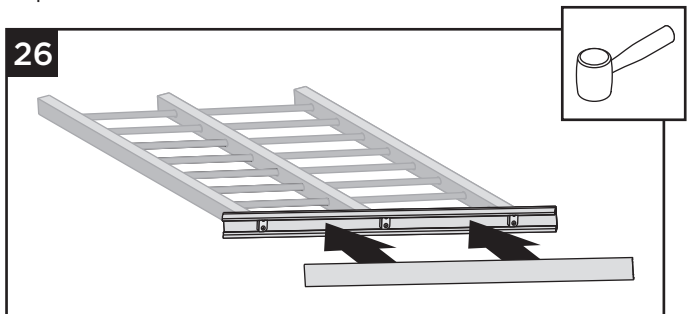

26. Using a mallet, install bottom rail cover onto bottom rail.

HOW TO INSTALL ROD RAIL STANDARD STAIR RAILING

TREX SIGNATURE®

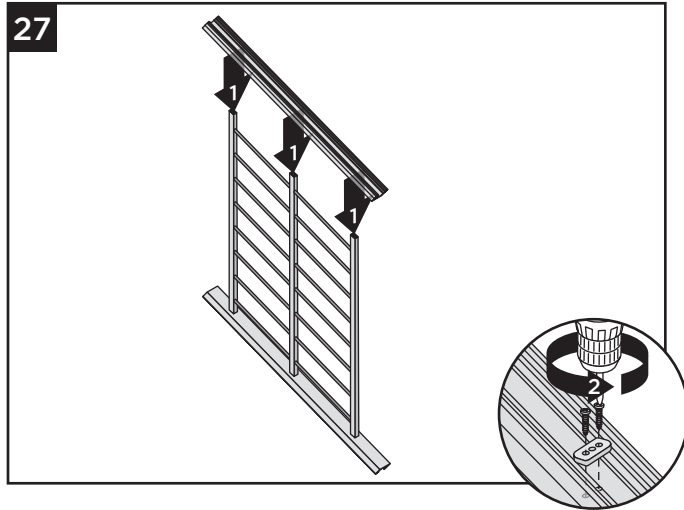

27. Install top rail to all vertical and end supports using ST Wedge Spacer and screws provided.

Attachment of Foot Block

Required **ONLY** for All Clear Span Applications over 6' (1.83 m). **NOTE THAT FOOT BLOCK IS SOLD SEPARATELY.**

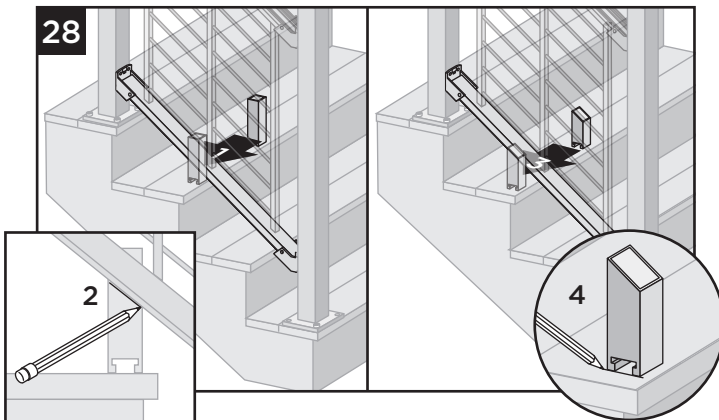

28. Temporarily drop assembled stair rod rail panel into brackets. To ensure proper location place foot block towards the nose of the stair tread along the side of the bottom rail. Mark location of angle on foot block and cut on mark. Then place foot block under the center of the bottom rail. Mark placement location of the base.

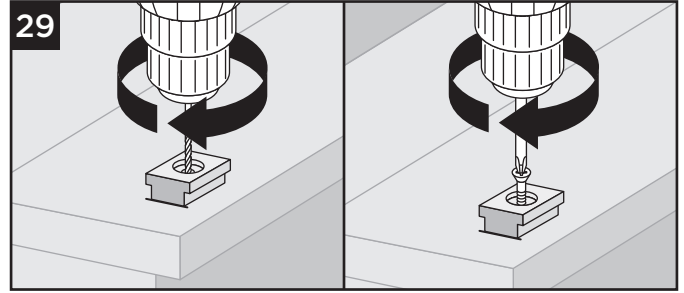

29. Place base (smaller side facing down) on decking surface. Pre-drill using a 3/16" bit. Attach base of foot block using one screw at an angle through base and into decking.

30. After attached, use a rubber mallet along with scrap piece of wood to tap foot block until it locks into place.

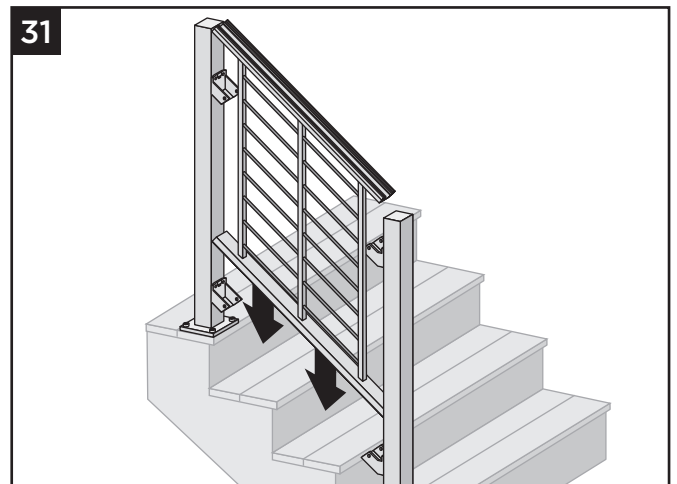
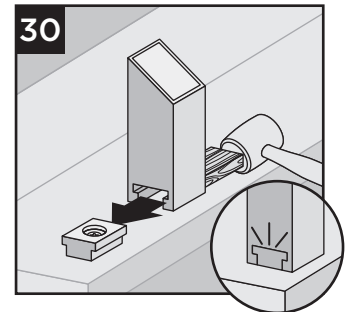

31. Drop assembled stair rod rail panel into brackets.

Attaching Stair Panel to Brackets

32. Attach bottom stair rail to bottom stair bracket using two self-tapping screws (provided) on each side of bracket.

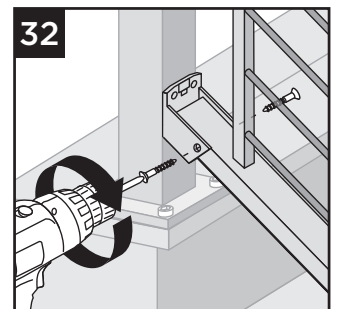

HOW TO INSTALL ROD RAIL STANDARD STAIR RAILING CONTINUED TREX SIGNATURE®

33. Attach top stair rail to top stair bracket (all types) using two self-tapping screws (provided) on each side of stair bracket.

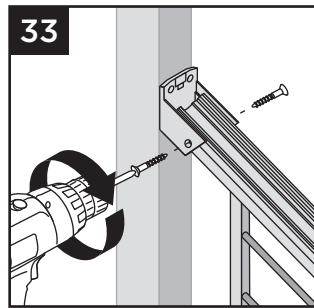

36. Attach provided post skirt to bottom of posts when using Trex Signature posts.

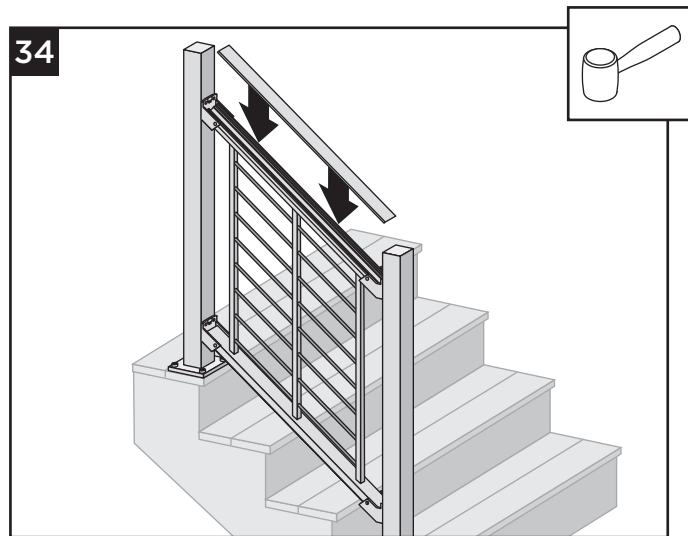
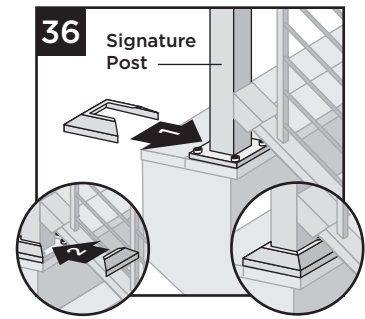

34. Using a mallet, install top rail cover.

Attachment of Bracket Covers, Skirts, and Caps

35. Attach corresponding bracket covers over opening in upper and bottom rails.

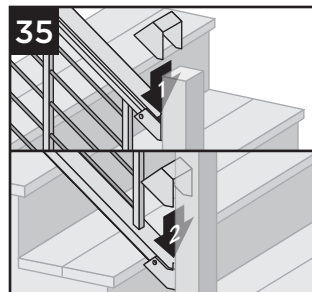

37. Attach post caps to Trex Signature posts. (Use of **rubber mallet** may be required for secure attachment.)

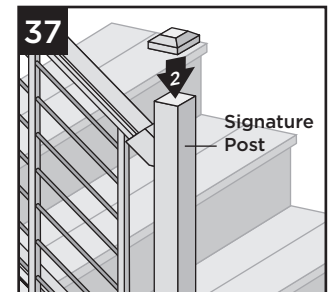

38. Attach post caps to post sleeves using external grade PVC construction adhesive (apply adhesive on the inside self-centering/corner tabs).

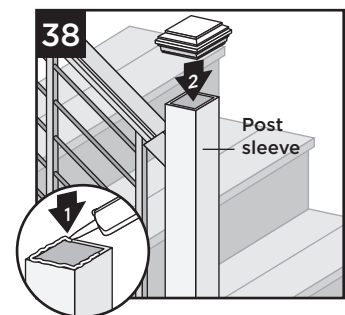

HOW TO INSTALL ROD RAIL STAIR CROSSOVER SWIVEL BRACKETS

TREX SIGNATURE®

- Cutting Bottom Rail**
See instructions on page 144.

- Install Lower Fixed Stair Brackets**
See instructions on page 144.
NOTE: These are installed on all posts, including the center crossover post.

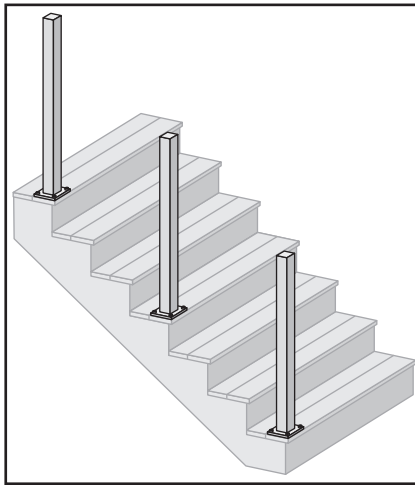

- Set bottom stair rail into bottom stair rail fixed brackets.

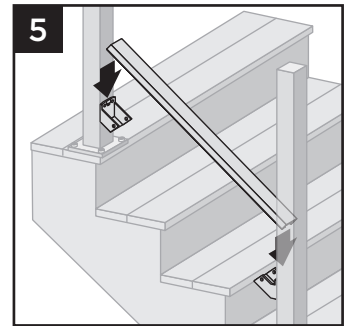

Install Upper Fixed Stair Brackets

NOTE: When using a center crossover post the, upper fixed stair brackets will only be installed at the terminating upper and lower post, and not the center crossover post.

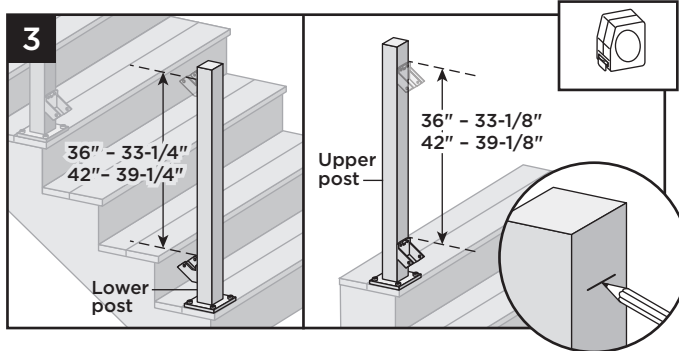

- On Lower Post** - From top of lower bracket, measure up and mark with light line (33-1/4" for 36" rail; 39-1/4" for 42" rail).
On Upper Post - From top of lower (upper) bracket, measure up and mark with light line (33-1/8" for 36" rail; 39-1/8" for 42" rail).

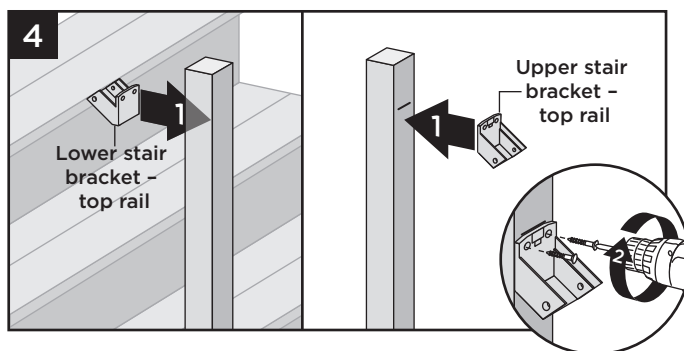

- Center upper stair brackets on posts **below** the marked lines and attach using two self-tapping screws (*provided*).

Determining Placement of Stair Crossover Swivel Bracket

- Insert stair crossover swivel bracket into post.

NOTE: Keep the bracket cover on when inserting this into post, this will cover the screw attachment area.

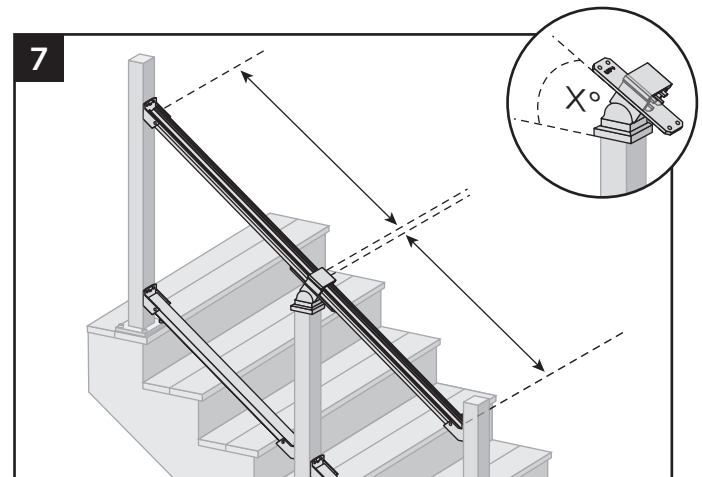
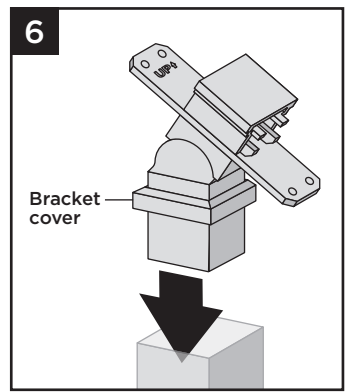

- Determine location/height of the stair crossover swivel bracket by aligning the angle of this with the fixed brackets already installed. Note that the crossover post may need to be cut to ensure the top stair rail is parallel to the bottom stair rail.

HOW TO INSTALL ROD RAIL STAIR CROSSOVER SWIVEL BRACKETS/CONTINUED TREX SIGNATURE®

Attaching Stair Crossover Swivel Bracket to Post

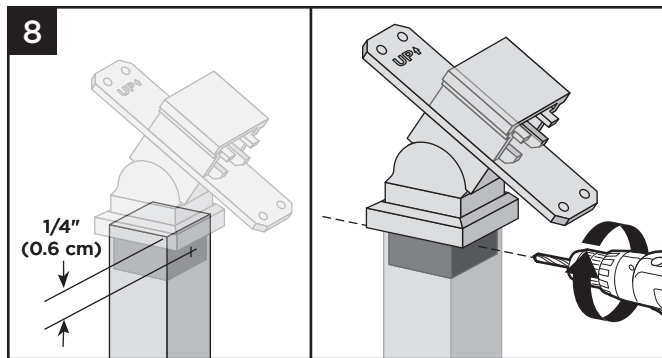

8. Once location/height is determined, center and predrill two holes (using a drill bit slightly smaller than that of self-tapping screw diameter) on opposite sides of post, approximately 1/4" (0.6 cm) from top of post. Drill through the post and into the stair crossover swivel bracket on each side.

NOTE: Slightly countersink pre-drilled holes to allow for flat head screws to seat flush on the post. This will allow cover to fit over screw heads.

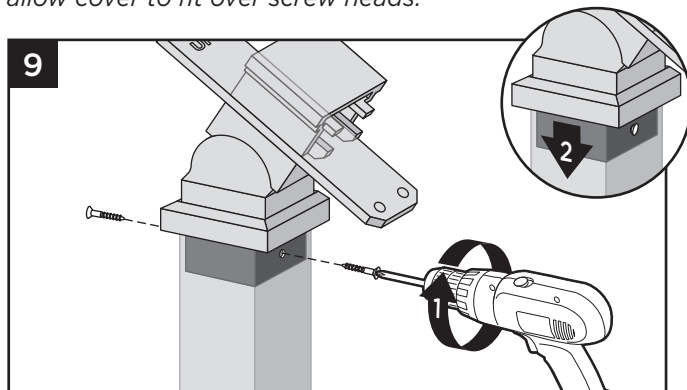

9. Attach stair crossover swivel bracket to post with two self-tapping screws (provided). Slide cover over post to hide screws.

Cutting Top Stair Rail For Stair Post-to-Stair Crossover Post Configuration

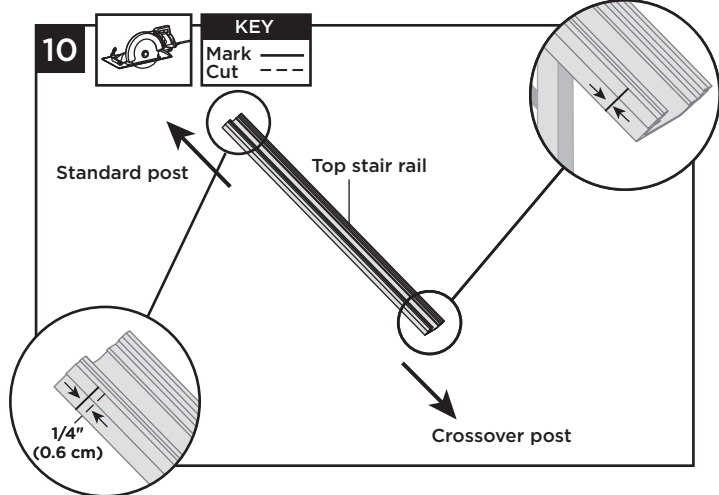

10. Top stair rail must be cut differently on each side of the rail. Railing side that attaches to standard post should be cut 1/4" (0.6 cm) shorter than the mark to allow for fit into top rail bracket. Railing side that attaches to the crossover post should be cut directly on the mark to allow for fit into the crossover post bracket.

NOTE: Railing does not need to be cut at angle. Brackets are designed to allow for railing to be installed with standard straight cut.

11. Measuring and Cutting Rods

See instructions on page 145.

12. Vertical and Rod Assembly

See instructions on page 147.

13. Installing Top and Bottom Rails

See instructions on page 147.

14. Attachment of Foot Block

See instructions on page 148.

Attachment of Stair Panel to Stair Brackets

15. Attach bottom stair rail to bottom stair bracket using two self-tapping screws (provided) on each side of bracket.

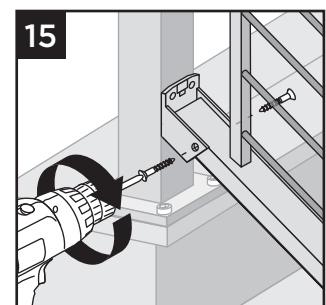

HOW TO INSTALL ROD RAIL STAIR CROSSOVER SWIVEL BRACKETS/CONTINUED TREX SIGNATURE[®]

16. For stair crossover post configuration, fasten upper stair rail to swivel crossover post bracket by installing screws diagonally through crossover stair bracket into upper rail using two self-tapping screws (provided) on each side.

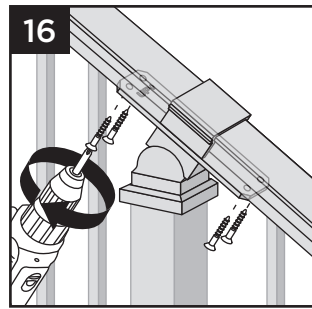

17. Attachment of Bracket Covers, Skirts, and Caps See instructions on page 149.

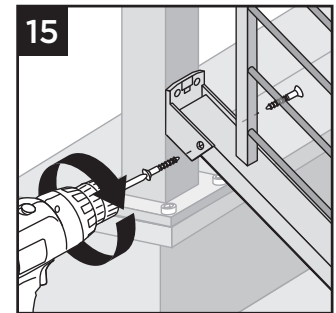

NOTE: Pre-drilling is required (7/64" [0.28 cm] drill bit) for attachment of stair railing to stair bracket.

HOW TO INSTALL COCKTAIL ROD RAIL STAIR RAILING TREX SIGNATURE[®]

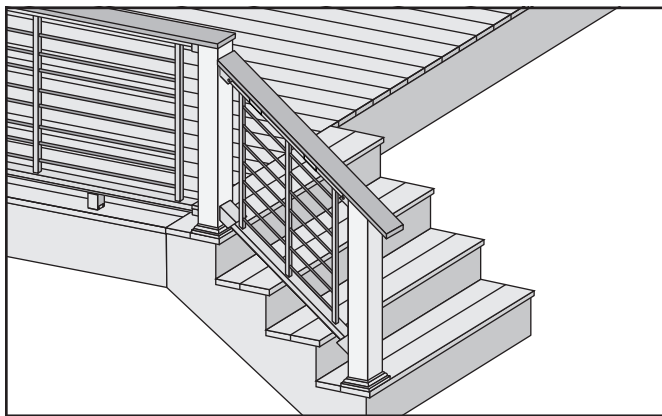

1. Installing Pressure-treated Posts, Post Sleeves and Skirts to Use with Trex Signature Railing
See instructions on page 143.

2. Installing Brackets

Follow previous stair instructions for the installation of desired brackets, making sure that all dimensions are calculated before installation, and ensuring deck board is placed in correct location.

Cutting Top Stair Rail

NOTE: THE TOP RAIL AND TOP RAIL COVER WILL NEED TO BE CUT AT APPROPRIATE ANGLE ON THE END OF THE RAIL THAT CONNECTS TO THE UPPER FIXED BRACKET, SO THAT WHEN THE RAIL IS INSTALLED IT SITS FLUSH WITH THE END OF THE BRACKET AS SHOWN.

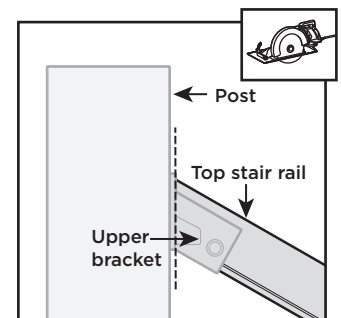

1. Follow all Rod Rail Stair instructions for the assembly of the rod rail stair panel.

IMPORTANT NOTES:

- » Only for use with pressure-treated 4 x 4 post (3.5" nominal square) and 4" x 4" (102 mm x 102 mm) post sleeve. Trex Signature posts, Trex post mounts or joist mount posts cannot be used with Trex Signature Cocktail Rod Rail stair railing. Cutting post and post sleeve only applies to the Cocktail style railing.
- » DO NOT CUT LOWER POST/POST SLEEVES UNTIL ROD RAIL STAIR PANEL IS FULLY INSTALLED.
- » When referring to previous instructions referenced, disregard all crossover post instructions as these cannot be used with Cocktail railing.
- » THE DECK BOARD USED IN COCKTAIL ROD RAIL STAIR WILL NEED TO TERMINATE AT THE UPPER STAIR POST AS SHOWN ABOVE. THE DECK BOARD WILL HAVE TO BE TOENAILED INTO THE SIDE OF THE POST IN THESE AREAS USING 2 APPROPRIATE COMPOSITE DECKING SCREWS - PRE-DRILLING IS RECOMMENDED.
- » Do Not use Enhance for top board.

HOW TO INSTALL COCKTAIL ROD RAIL STAIR RAILING/CONTINUED

TREX SIGNATURE®

Cutting Post and Post Sleeve and Attaching Deck Board to Top Rail

2. Cut post and post sleeves at proper angle so these are flush with the top of the top brackets and/or top rail cover. BE CAREFUL **NOT** to CUT brackets.

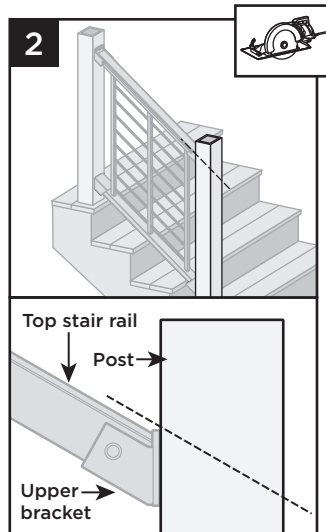

3. Place deck boards over top rails. **DO NOT** use Enhance deck boards for top rail. PLACE DECK BOARD ON TOP RAIL TO CHECK FOR PROPER FIT AND RAIL CLEARANCE AT BRACKET LOCATIONS. DECK BOARD MAY REQUIRE EITHER A NOTCH CUT ON THE UNDERSIDE OR SLIGHT PLANING ON THE UNDERSIDE TO ALLOW DECK BOARD TO CLEAR TOPS OF BRACKETS AND SIT FLUSH ON TOP OF POSTS AND RAILS. Attach boards on each post with Trex-recommended composite screws (quantity of 2 per each post/board end).

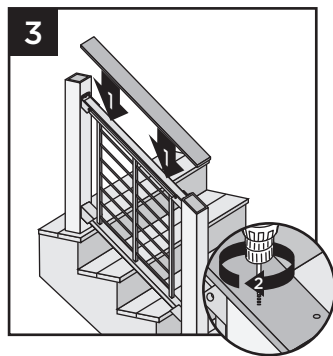

4. Secure boards to top rail using Trex Signature Cocktail Bracket (sold separately). Ensure that there is a bracket at each end of the stair railing section, then space brackets approximately every 24" and attach with 4 screws provided.

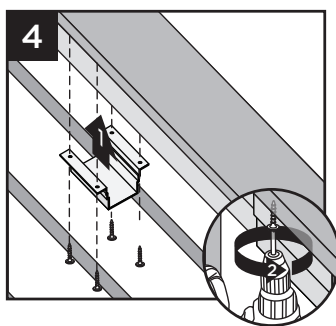

NOTE: Pre-drilling before attachment is recommended.

5. Use scarf cut for posts where two deck boards meet.

NOTES:

- » Leave 1/8" (3 mm) gap between deck boards.
- » Deck boards can overhang end of last post maximum 1/2" (13 mm).

6. Where deck board terminates at upper post, PREDRILL and toenail two approved composite deck screws as shown into post, being careful to avoid hitting stair bracket.

NOTE: Top Bracket Covers are not attached in this configuration.

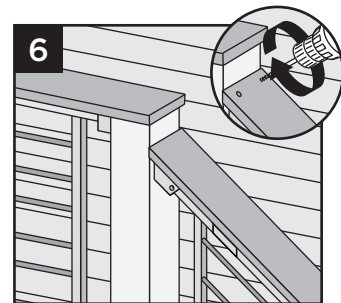
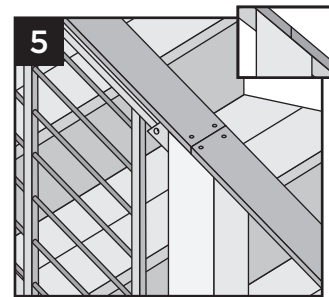

HOW TO INSTALL TRADITIONAL ROD RAIL STAIR RAILING

TREX SIGNATURE®

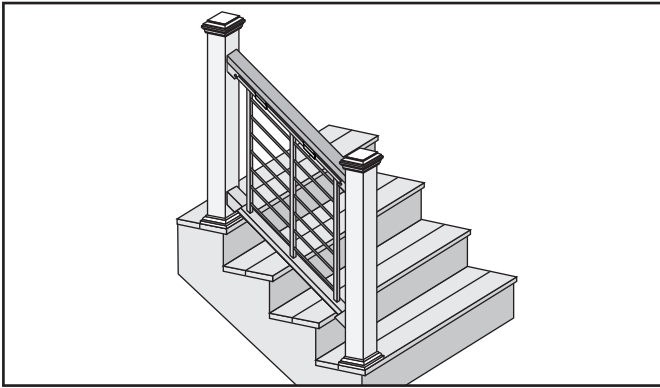

IMPORTANT NOTES:

- » Only for use with pressure-treated 4 x 4 post (3.5" nominal square) and 4" x 4" (102 mm x 102 mm) or 6" x 6" post sleeves, Trex Post Mounts or Trex Joist Mount Post WITH Trex post sleeves. Signature Joist Mount Posts cannot be used with Trex Signature Traditional railing.
- » THE TOP RAIL AND TOP RAIL COVER WILL NEED TO BE CUT AT APPROPRIATE ANGLE ON THE END OF THE RAIL THAT CONNECTS TO THE UPPER FIXED BRACKET, SO THAT WHEN THE RAIL IS INSTALLED IT SITS FLUSH WITH THE END OF THE BRACKET AS SHOWN.

1. Installing Pressure-treated Posts, Post Sleeves, and Skirts to Use with Trex Signature Railing

See instructions on page 143.

2. Installing Brackets

Follow previous stair instructions for the installation of desired brackets, making sure that all dimensions are calculated before installation, and ensuring railing is placed in correct location.

Cutting Top Stair Rail

NOTE: THE TOP RAIL AND TOP RAIL COVER WILL NEED TO BE CUT AT APPROPRIATE ANGLE ON THE END OF THE RAIL THAT CONNECTS TO THE UPPER FIXED BRACKET, SO THAT WHEN THE RAIL IS INSTALLED IT SITS FLUSH WITH THE END OF THE BRACKET AS SHOWN.

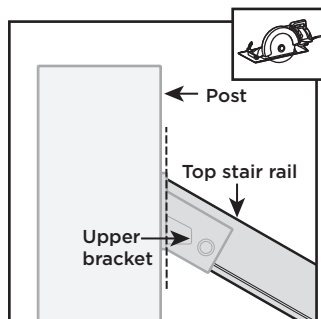

1. Follow all Rod Rail Stair instructions for the assembly of the rod rail stair panel

Attaching 2 x 4 to Top Rail

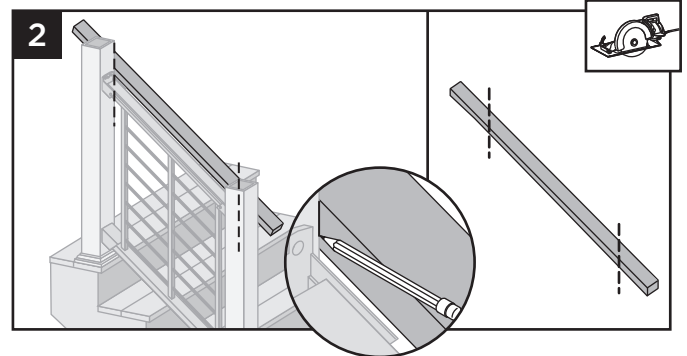

2. Place 2 x 4 beside top rail. Mark and cut (both ends need to be cut on an angle for proper fit).
3. Place 2 x 4 on top stair rail.

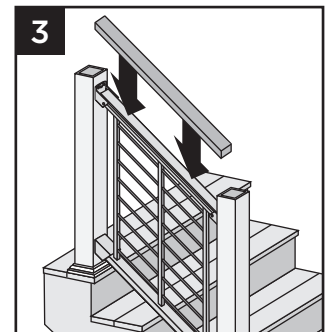

4. Secure 2 x 4 to top rail using Trex Signature™ Cocktail Bracket (sold separately). Ensure that there is a bracket at each end of the railing section, then space brackets approximately every 24" and attach with 4 screws provided.

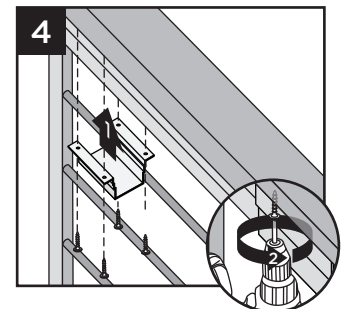

NOTE: Pre-drilling before attachment is recommended.

5. Pre-drill a pilot hole and toenail 2-1/2" (6.4 cm) screw at each end of 2 x 4 into post on back side of rail (side not facing decking).

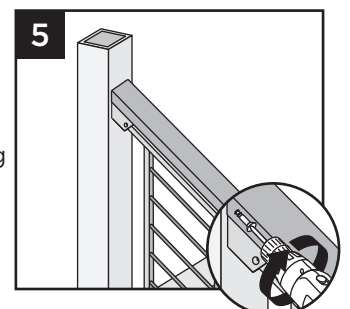

NOTE: Top Bracket Covers are not attached in this configuration.

HORIZONTAL GLASS RAILING TREX SIGNATURE®

NOTES:

- » FOR ORDERING STANDARD OR CUSTOMIZED GLASS PANEL SIZES, GO TO GLASS.TREX.COM. FOR MORE INFORMATION CALL 1-800 BUY TREX.
- » TREX SIGNATURE GLASS RAILINGS ARE DESIGNED TO BE ATTACHED WITH POSTS INSTALLED AT A MAXIMUM CLEAR SPAN OF 6' (1.83M).
- » NOTE: MUST USE TREX DECK MOUNT POST HARDWARE AND METAL PLATE WHEN ATTACHING TREX SIGNATURE POSTS.
- » NOT RECOMMENDED FOR STAIR APPLICATIONS.
- » SEE BELOW FOR SPECIFIC GLASS DIMENSIONS.
- » ALWAYS REFER TO YOUR LOCAL BUILDING CODE OFFICIAL PRIOR TO INSTALLING ANY RAILING SYSTEM TO ENSURE ALL CODE AND SAFETY REQUIREMENTS ARE MET. TREX® CANNOT BE HELD RESPONSIBLE FOR IMPROPER OR NON-RECOMMENDED INSTALLATIONS.
- » ONE FOOT BLOCK IS REQUIRED FOR ALL GLASS PANEL INSTALLATION, THUS THESE RAILING SPANS MUST BE INSTALLED OVER THE DECKING FRAME OR ON INSIDE OF RIM JOIST.

PARTS

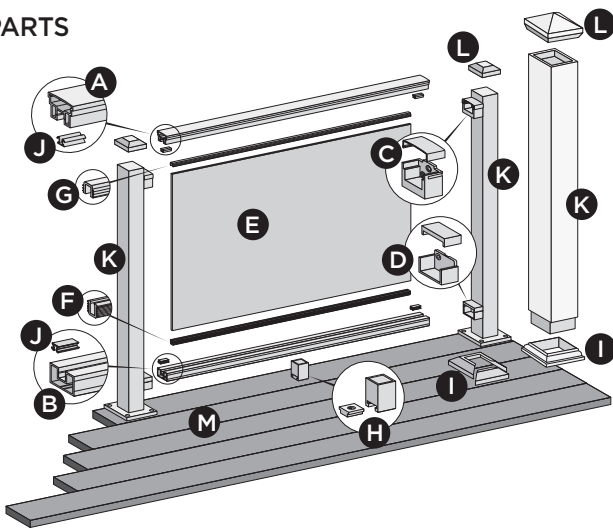

NOTE: IMAGE SHOWN HERE IS POST TO POST CONFIGURATION.

TEMPERED GLASS PANEL DIMENSIONS

- » **36" (914 mm) high rail:**
1/4" x 32-5/16" x 67" max.
(6 mm x 821 mm x 1702 mm)
- » **42" (1067 mm) high rail:**
1/4" x 38-5/16" x 67" max.
(6 mm x 973 mm x 1702 mm)

NOTE: IF NOT INSTALLING GLASS AT FULL RAILING SPAN, GLASS MUST BE CUT TO ALLOW FOR 2 1/2" CLEARANCE ON EACH SIDE OF POST (DO NOT EXCEED 4").

Screws Supplied



#8 x 1-1/4" Rail to
Bracket Screw



#10 x 5/8" Bracket to
Post Screw

- A. Trex Signature Glass top rail - 6' (actual length 73.5" [186.7 cm])
- B. Trex Signature Glass bottom rail - 6' (actual length 71.5" [181.6 cm])
- C. Trex Signature upper rail bracket and cover
- D. Trex Signature lower rail tabless bracket and cover
- E. Tempered glass panel* (NOT included in kit)
- F. Bottom Sill Gasket
- G. Top Head Gasket
- H. Trex Signature foot block (REQUIRED FOR ALL TREX SIGNATURE GLASS INSTALLATIONS)
- I. Trex Signature post skirt or post sleeve skirt*
- J. Snap-in Channel Filler
- K. Trex Signature post*
 - 36" (actual length 37" [94.0 cm])
 - 42" (actual length 43" [109.2 cm])
 or Trex 4" x 4" post sleeve**
 - 36" (actual length 40" [102 cm])
 - 42" (actual length 46" [117 cm])

- L. Trex Signature post cap or post sleeve cap*

* Item not included in Trex Signature Railing kits. Trex Signature Posts (black only) can also be purchased with brackets installed, eliminating steps 1-4 in instructions below. Sku numbers are as follows:

SKU number	Description
BKAL252537RCAPCNR	Signature Post 37" Corner Post
BKAL252537RCAPEND	Signature Post 37" End Post
BKAL252537RCAPLINE	Signature Post 37" Inline Post
BKAL252543RCAPCNR	Signature Post 43" Corner Post
BKAL252543RCAPEND	Signature Post 43" End Post
BKAL252543RCAPLINE	Signature Post 43" Inline Post

** Both 4" x 4" (10.2cm x 10.2cm) and 6" x 6" (15.2cm x 15.2cm) post sleeves are designed to fit over a 4" x 4" pressure treated post.

Installing Posts

REFER TO DETAILED INSTRUCTIONS ON HOW TO INSTALL TREX SIGNATURE POSTS OR PRESSURE TREATED POSTS.

HOW TO INSTALL HORIZONTAL GLASS RAILING BRACKETS TREX SIGNATURE®

NOTES:

- » FOR EASE OF INSTALLATION, IT IS RECOMMENDED TO USE THE TREX SIGNATURE RAIL TEMPLATES TO ATTACH BRACKETS (SOLD SEPARATELY).
- » TREX SIGNATURE POSTS CAN ALSO BE PURCHASED SEPARATELY WHICH HAVE BRACKETS PREINSTALLED, THUS SKIPPING STEPS 1-4. SEE PREVIOUS PAGE FOR SKU NUMBERS.

Attach Brackets Using Trex Signature Posts

TIP: Use a clamp to help hold brackets in place while fastening with screws.

1. Measure 1-3/8" (3.5 cm) from top of post base plate or 1-7/8" (4.8 cm) from decking surface. Mark with light line.

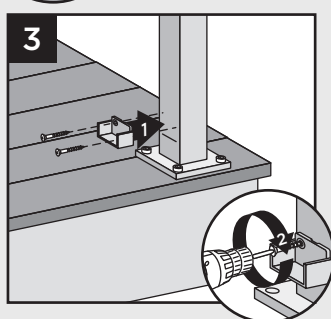
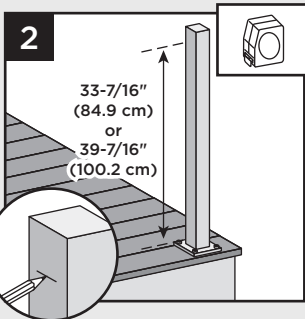
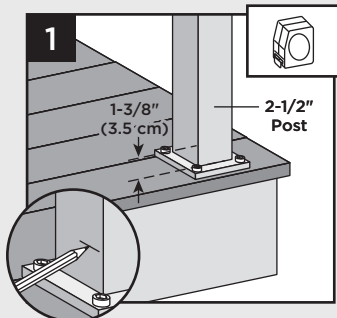

2. Measure up from post base plate 33-7/16" (84.9 cm) for 36" (92 cm) rail height or 39-7/16" (100.2 cm) for 42" (107 cm) rail height. Mark with light line.

NOTE: If measuring from decking surface, measure up 33-15/16" (86.2 cm) for 36" (92 cm) rail height or 39-15/16" (101.4 cm) for 42" (107 cm) rail height.

3. Center lower bracket on post **above** the marked line and attach using (2) self-tapping screws (provided).
4. Center upper bracket on post **above** marked line and attach using (3) self-tapping screws (provided).

NOTE: Upper bracket is not required on crossover post configuration.

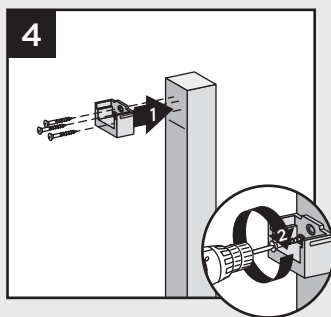

Attach Brackets Using Pressure-Treated Posts and Post Sleeves

TIP: Use a clamp to help hold brackets in place while fastening with screws.

1. Measure 1-7/8" (4.8 cm) up from deck surface to bottom of bracket. Slide skirt up to allow for proper measurement. Mark with light line.

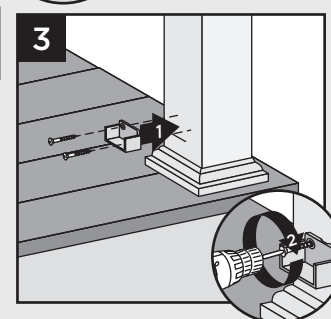
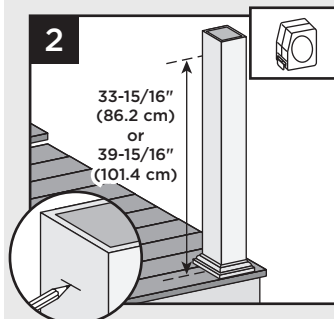
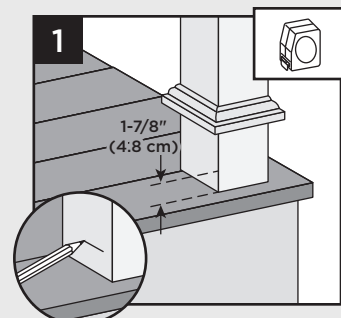

2. Measure up from decking surface 33-15/16" (86.2 cm) for 36" (92 cm) rail height or 39-15/16" (101.4 cm) for 42" (107 cm) rail height. Mark with light line.

NOTE: Push skirt back down onto surface of decking **BEFORE ATTACHING BRACKETS.**

3. Center lower bracket on post **above** the marked line and attach using two 2" (51 mm) wood screws (provided).
4. Center upper bracket on post **above** marked line and attach using three 2" (51 mm) wood screws (provided).

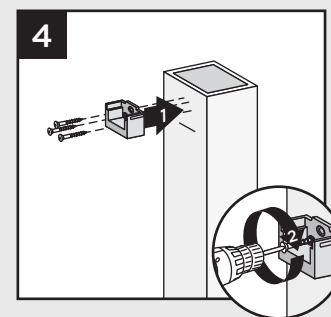

HOW TO INSTALL HORIZONTAL GLASS RAILING SWIVEL BRACKETS

TREX SIGNATURE®

Attach Swivel Brackets Base Using Trex Signature Posts

TIP: Use a clamp to help hold brackets in place while fastening with screws.

1. Measure 1-3/8" (3.5 cm) from top of post base plate or 1-7/8" (4.8 cm) from decking surface. Mark with light line.

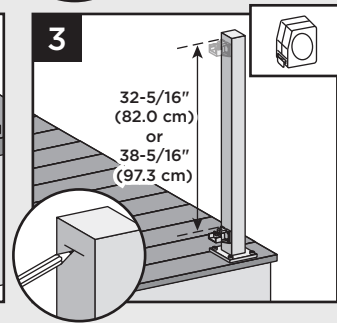
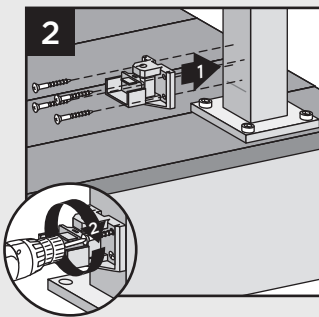
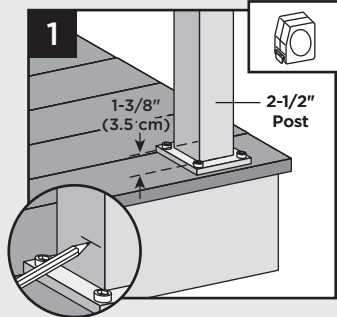

2. Center lower bracket on post **above** the marked line and attach using four self-tapping screws (*provided*).
3. Measure up 32-5/16" (82.0 cm) for 36" (91.4 cm) tall railing or 38-5/16" (97.3 cm) for 42" (106.7 cm) tall railing from top of lower rail bracket. Mark with a light line.
4. Center upper bracket on post **below** marked line and attach using four self-tapping screws (*provided*).

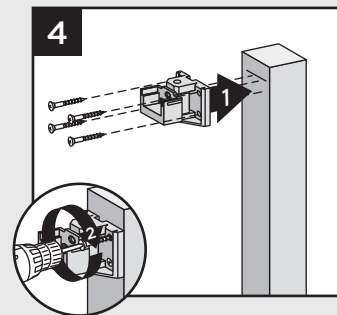

NOTE: Upper bracket is not required on crossover post configuration.

Attach Swivel Brackets Using Pressure-treated Posts and Post Sleeves

TIP: Use a clamp to help hold brackets in place while fastening with screws.

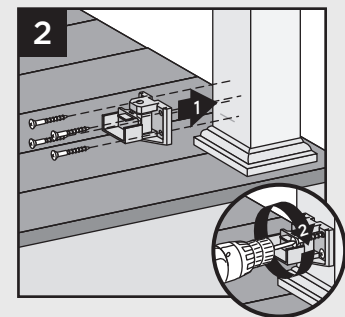
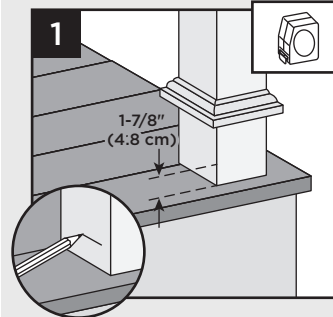

1. Measure 1-7/8" (4.8 cm) up from deck surface to bottom of bracket. Slide skirt up to allow for proper measurement, then push skirt back down onto surface of decking **BEFORE ATTACHING BRACKET**. Mark with light line.
2. Center lower bracket on post **above** the marked line and attach using four 2" (5.1 cm) wood screws (*provided*).

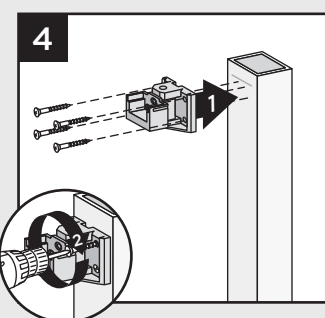
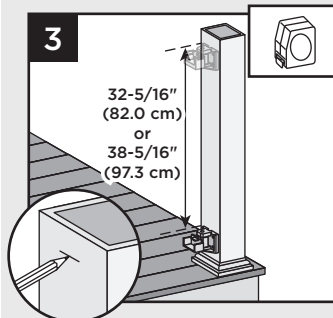

3. Measure up 32-5/16" (82.0 cm) for 36" (91.4 cm) tall railing or 38-5/16" (97.3 cm) for 42" (106.7 cm) tall railing from top of lower rail bracket. Mark with a light line.
4. Center upper bracket on post **below** marked line and attach using four 2" (5.1 cm) wood screws (*provided*).

HOW TO INSTALL STANDARD HORIZONTAL GLASS RAILING/CONTINUED TREX SIGNATURE®

5. Prepare a clean, soft, solid work surface area for glass (cardboard, blanket, etc.).

How to Measure and Cut Bottom and Top Rails

For Full Span Post to Post Applications - only top rail will need to be cut. For Full Span Crossover to Crossover post Applications - no rails have to be cut.

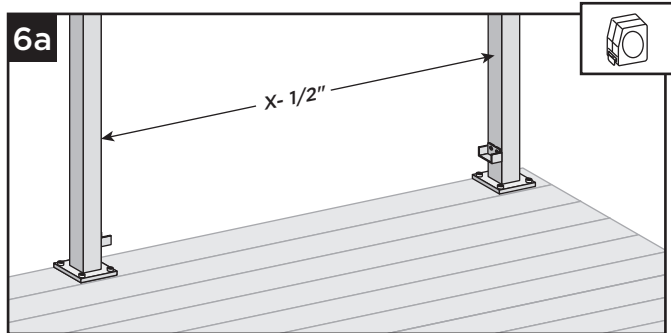

6a. Measure distance between posts (X), and subtract 1/2" for bracket clearance.

If installing crossover post configurations, adjust top rail length: $X + 3/4"$ if using one crossover post, or $X + 1 1/2"$ if using two crossover posts. If using swivel brackets, measure distance between brackets and cut railings to this distance. In addition, if tabbed bottom swivel brackets are installed the tab must be removed from bottom swivel brackets.

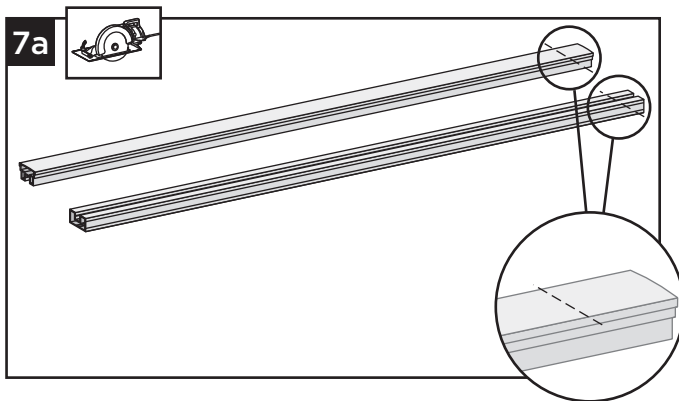

7a. Cut both bottom and top rails to length as determined above.

Attachment of Foot Block (One Foot Block is Required for Any Length Glass Railing Span)

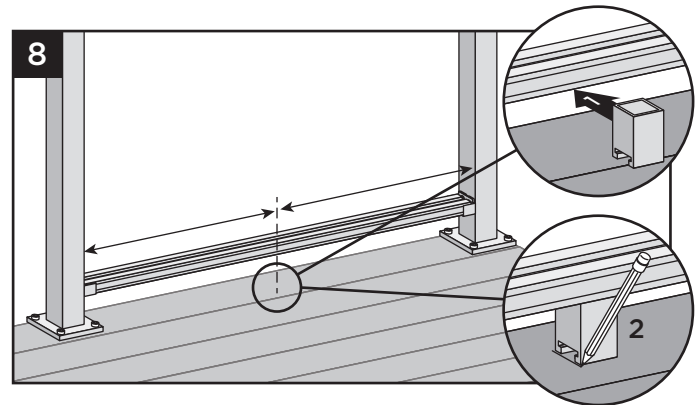

8. Temporarily place bottom rail into lower bracket. To ensure correct location, place foot block under center of bottom rail. Mark to provide placement location of base.

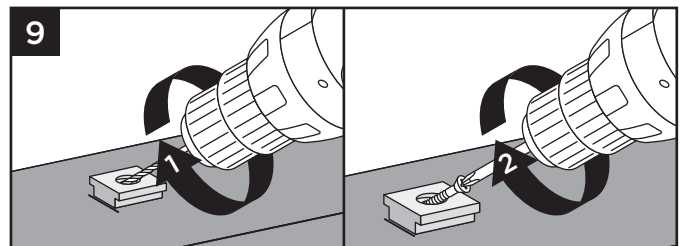

9. Remove bottom rail from lower brackets. Place base (smaller side facing down) on decking surface. Pre-drill using a 3/16" bit. Attach base of foot block using one screw at an angle through base and into decking.



HOW TO INSTALL STANDARD HORIZONTAL GLASS RAILING/CONTINUED TREX SIGNATURE®

10. After attached, use a rubber mallet along with scrap piece of wood to tap foot block until it locks into place.

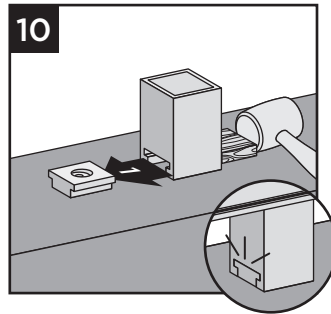

Installing Bottom Rail

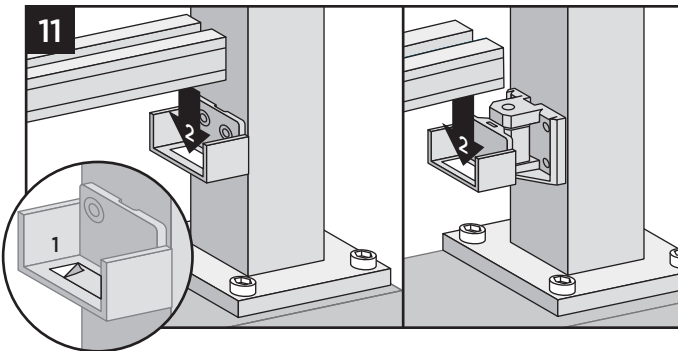

11. Place adhesive strips (provided) into bottom rail brackets, and then place bottom rail into brackets.

NOTE: Make sure surface is clean and dry.

Cutting Gaskets

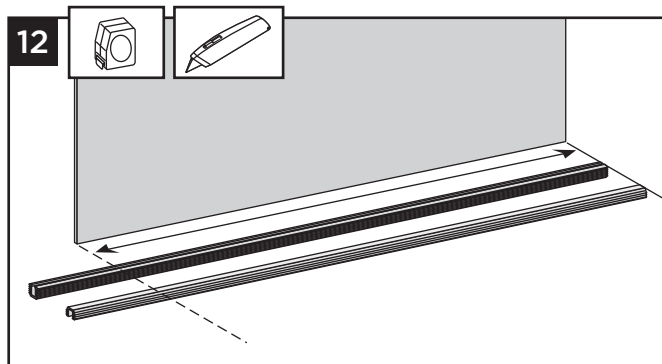

12. Cut both bottom sill gasket and top head gasket to the same length of glass panel.

Installing Bottom Sill Gasket

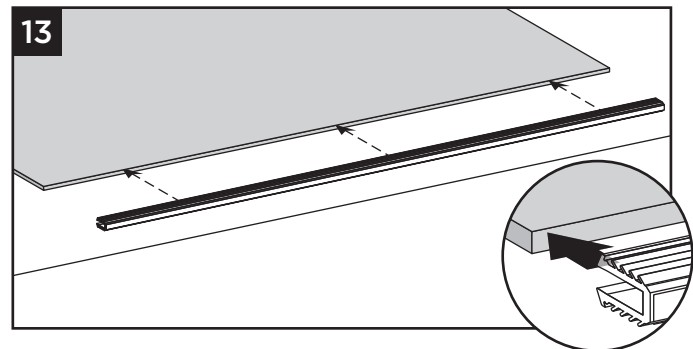

13. Lay glass on clean soft surface and install the bottom sill gasket onto the bottom edge of the glass panel.

Centering the Glass and Installing into Bottom Rail

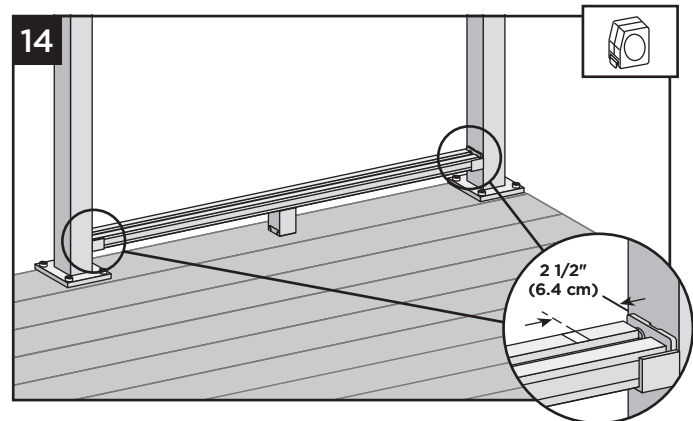

14. For full span installation, make a temporary mark on the bottom rail (example: use removable tape) 2-1/2" from each post. This will allow for glass to be centered between posts on bottom rail.

For all other spans, make sure glass is centered **BEFORE** installing into bottom rail. **WARNING: DO NOT** exceed 4" between glass and post.

THIS IS IMPORTANT AS THE GLASS MUST BE CENTERED ON THE BOTTOM RAIL BEFORE INSTALLATION, AS THIS IS VERY DIFFICULT TO REMOVE IF PLACED INCORRECTLY.



HOW TO INSTALL STANDARD HORIZONTAL GLASS RAILING/CONTINUED TREX SIGNATURE®

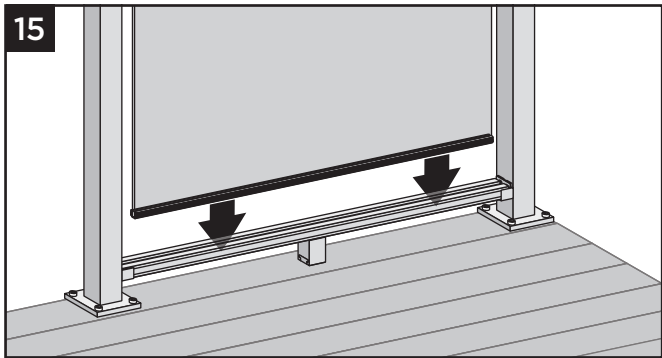

15. Press glass panel (with bottom sill gasket on glass) firmly into the bottom rail.

NOTE: Make sure glass is being secured by hand until final assembly of the top rail.

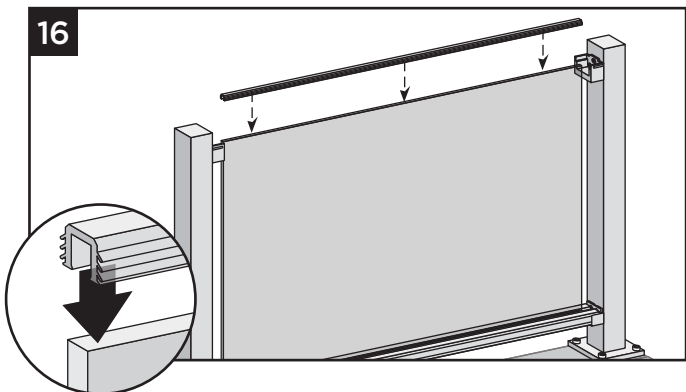

16. Install top head gasket onto the top of the glass panel. Note that the gasket may be loose at this stage.

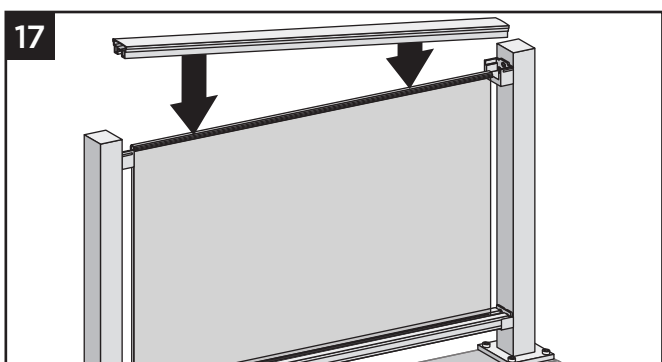

17. Starting at one end and working down, press the top rail firmly onto the top of the glass panel (with top head gasket on glass). Ensure the top rail is centered properly and top rail will seat into brackets when finished.

Attaching Top Rail to Brackets

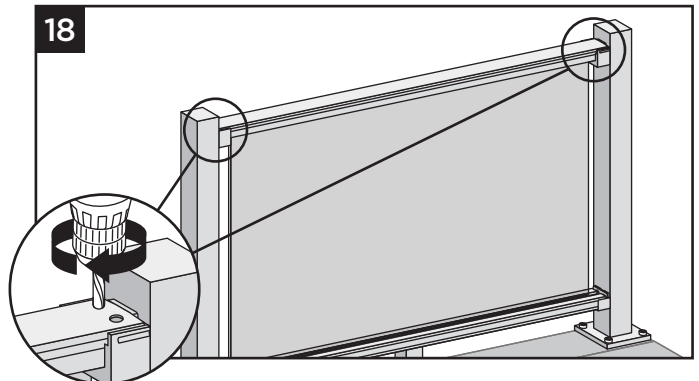

18. Drill two 1/2" holes approximately 1/2" from end of top rail. Repeat this on opposite side of top rail.

IMPORTANT NOTES:

- » HOLES CANNOT EXTEND PAST BRACKET, OTHERWISE BRACKET COVER WILL NOT COVER HOLES.
- » ONLY DRILL 1/2" HOLES THRU TOP WALL OF TOP RAIL. DO NOT USE A STEP BIT.

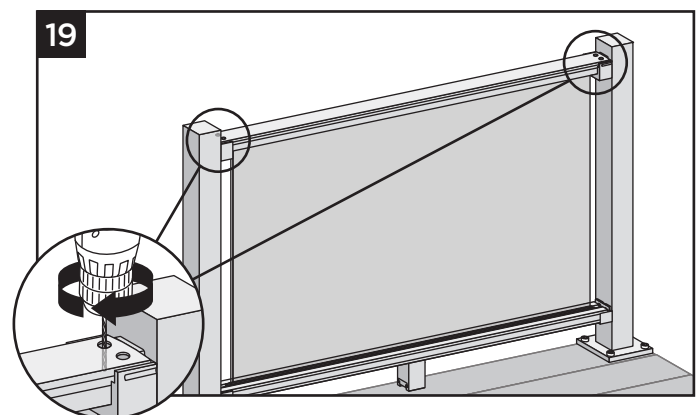
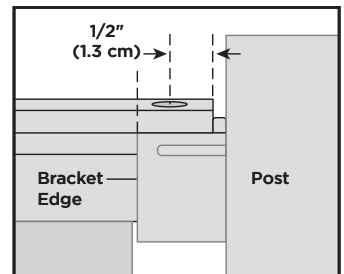

19. Using 9/64" bit provided, center into above holes and **PREDRILL** into top rail bracket at a depth of approximately 1-1/4". Use care to not drill through underside of top bracket.

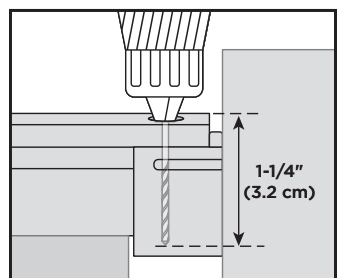

HOW TO INSTALL STANDARD HORIZONTAL GLASS RAILING/CONTINUED TREX SIGNATURE®

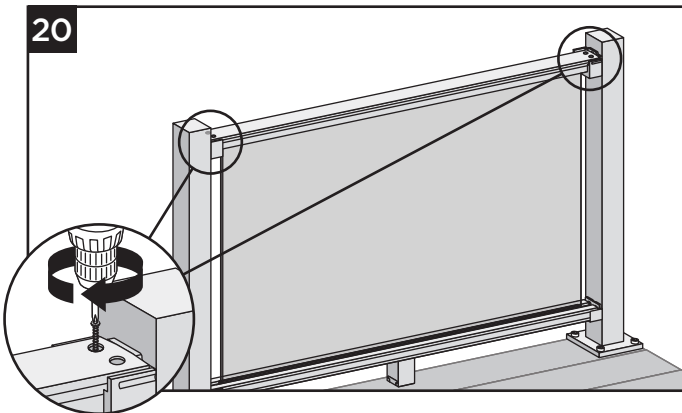

20. Install two #8 x 1-1/4" screws provided into top rail and top bracket on each end of top rail.

Installing Snap-in Channel Filler

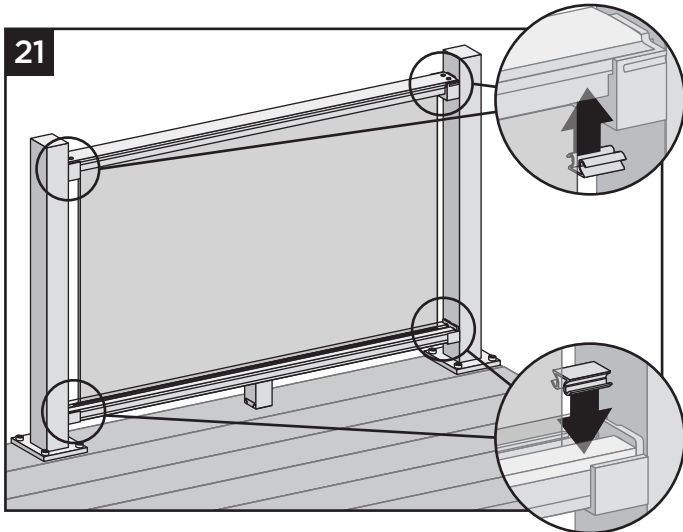

21. Cut snap-in channel filler to correct length and install into channels of bottom and top rails. Use of a rubber mallet may assist with this step. **DO NOT** attempt to cut short snap-in pieces with a miter saw. Use an angle grinder or hack saw only.

Attachment of Bracket Covers, Skirts, and Caps

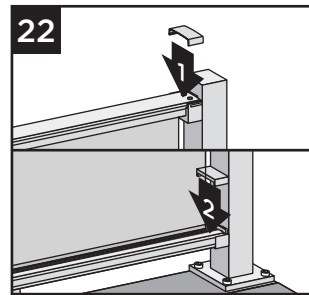

22. Attach corresponding bracket covers over opening in top and bottom rails.

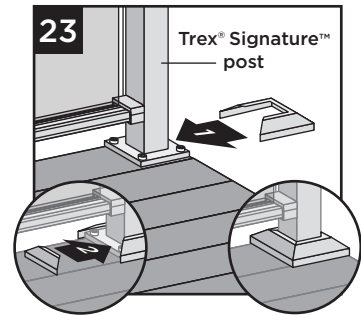

23. Attach provided post skirt to bottom of posts when using Trex Signature posts.

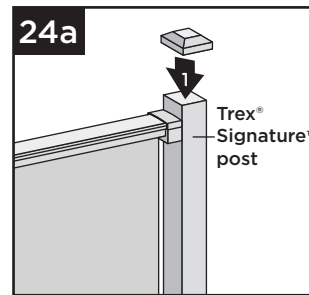

24a. Attach post caps to Trex Signature posts. (Use of **rubber mallet** may be required for secure attachment.)

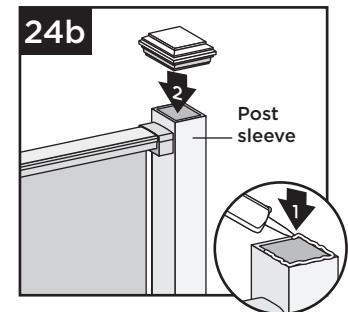

24b. Attach post caps to post sleeves using external grade PVC construction adhesive (apply adhesive on the inside self-centering/corner tabs).

HORIZONTAL MESH RAILING TREX SIGNATURE®

NOTES:

- » TREX SIGNATURE MESH RAILINGS ARE DESIGNED TO BE ATTACHED WITH POSTS INSTALLED AT A MAXIMUM CLEAR SPAN OF 6' (1.83M) OR 8' (2.44M).
- » MUST USE TREX DECK MOUNT POST HARDWARE AND METAL PLATE WHEN ATTACHING SIGNATURE POSTS IN GUARDRAIL APPLICATIONS.
- » FOR FULL SPAN INSTALLATIONS, MESH WILL NOT NEED TO BE CUT WITH THE EXCEPTION OF 6' X 42". IF INSTALLING AT THIS SIZE, PURCHASE 8' X 42" MESH AND CUT TO THE PROPER LENGTH.
- » ALWAYS REFER TO YOUR LOCAL BUILDING CODE OFFICIAL PRIOR TO INSTALLING ANY RAILING SYSTEM TO ENSURE ALL CODE AND SAFETY REQUIREMENTS ARE MET. TREX CANNOT BE HELD RESPONSIBLE FOR IMPROPER OR NON-RECOMMENDED INSTALLATIONS.
- » A FOOTBLOCK IS REQUIRED FOR ALL SPANS OF TREX SIGNATURE MESH RAIL. THUS THESE RAILING SPANS MUST BE INSTALLED OVER THE DECKING FRAME OR ON INSIDE OF RIM JOIST.
- » ENSURE THAT EACH MESH PANEL IS ORIENTED IN SAME DIRECTION FOR EACH SECTION PRIOR TO BEING INSTALLED.

CURVED MESH INSTALLATION NOTES:

- » DESIGN AND FABRICATION FOR CURVED MESH RAILINGS MUST BE HANDLED BETWEEN TREX COMMERCIAL PRODUCTS (TCP) AND THE CONTRACTOR/CUSTOMER. FOR MORE INFORMATION VISIT TREX.COM OR CALL 1-800-BUY-TREX.
- » CURVED MESH RAILING MUST BE INSTALLED USING HORIZONTAL SWIVEL BRACKETS.
- » FOLLOW ALL INSTRUCTIONS AS LISTED BELOW (WITH THE USE OF SWIVEL BRACKETS) FOR INSTALLATION OF CURVED MESH.

PARTS

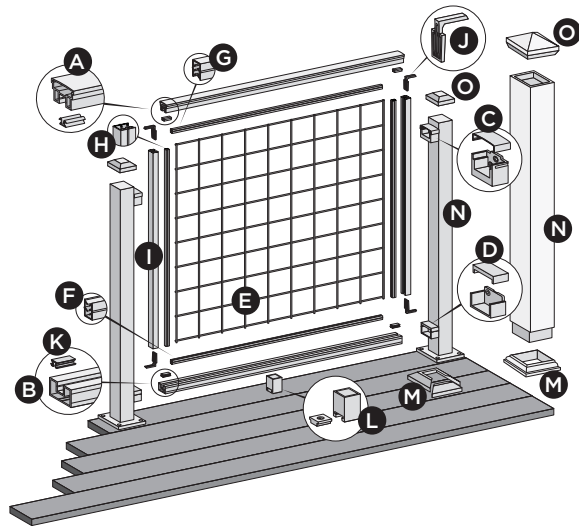

NOTE: IMAGE SHOWN HERE IS POST TO POST CONFIGURATION

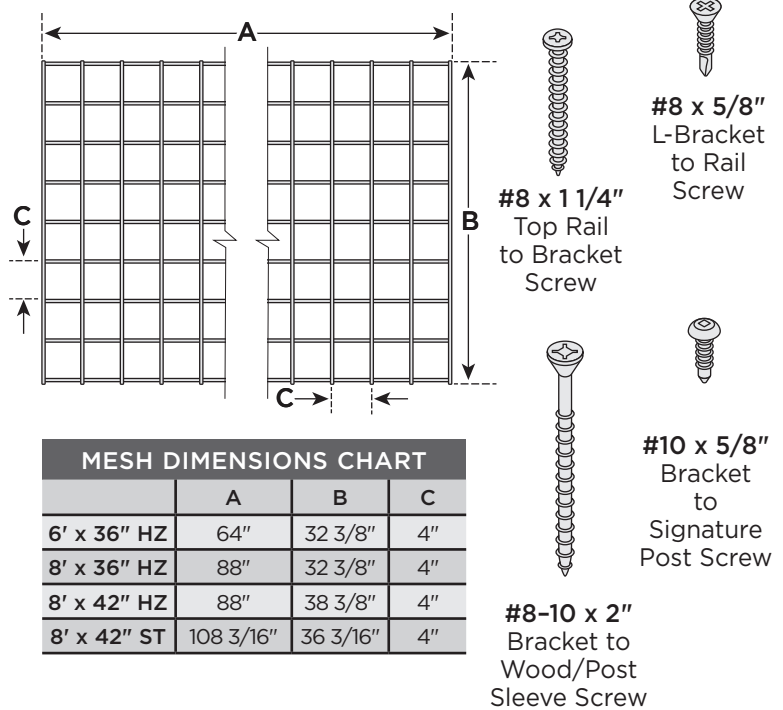

- A. Trex Signature Mesh top rail
 - 6' (actual length 73.5" [186.7 cm])
 - 8' (actual length 97.3" [247.7 cm])
- B. Trex Signature Mesh bottom rail
 - 6' (actual length 71.5" [181.6 cm])
 - 8' (actual length 95.5" [242.6cm])
- C. Trex Signature upper rail bracket and cover
- D. Trex Signature lower rail tabless bracket and cover
- E. Mesh Panel - see chart above for dimensions
- F. Horizontal PVC Gasket
- G. Horizontal PVC Gasket
- H. Vertical PVC Gaskets
- I. Vertical Supports
- J. L-Brackets
- K. Snap-in Channel Filler
- L. Trex Signature foot block (REQUIRED FOR ALL SPANS - MESH INSTALLATIONS)
- M. Trex Signature post skirt or post sleeve skirt*
- N. Trex Signature post*
 - 36" (actual length 37" [94.0 cm])
 - 42" (actual length 43" [109.2 cm])
 - or Trex 4" x 4" post sleeve**
 - 36" (actual length 40" [102 cm])
 - 42" (actual length 46" [117 cm])
- O. Trex Signature post cap or post sleeve cap*
 - * Item not included in Trex Signature Railing kits.
 - ** Both 4" x 4" (10.2cm x 10.2cm) and 6" x 6" (15.2cm x 15.2 cm) post sleeves are designed to fit over a 4" x 4" pressure treated post.

NOTE: If installing 42" (106.7 cm) railing, and using pressure-treated posts with Trex post sleeves, ensure that a longer pressure-treated post is used along with longer post sleeve, both cut to a height of 46" (116.8 cm) from decking surface.

RAILING CONFIGURATIONS

Note: See specific installation instructions for attachment of Trex post mounts or Trex Joist Mount Posts prior to installing any railing.

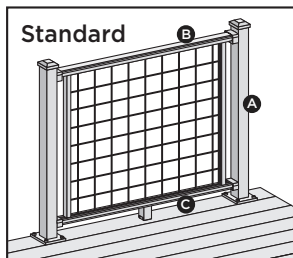

Cutting posts/post sleeves is **NOT** required.

A. Trex Signature post, pressure-treated post or Trex Post Mounts with Trex post sleeves, or Trex Joist Mount Posts

B. Trex Signature top rail

C. Trex Signature bottom rail

See page 166 for "How to Install Standard Mesh Railing".

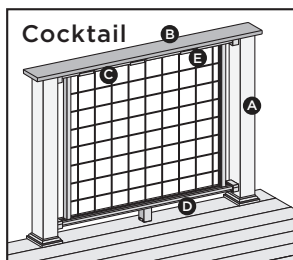

Post sleeves will need to be cut.

A. Pressure-treated post with Trex post sleeve

NOTE: » Only for use with 4" x 4" (102 mm x 102 mm) post sleeve.

» Trex Signature Posts, Trex Post Mounts or Joist Mount Posts cannot be used with Trex Signature Cocktail design.

B. Deck board top rail. **NOTE:** Enhance cannot be used.

C. Trex Signature top rail

D. Trex Signature bottom rail

E. Trex Signature Cocktail Rail Bracket**

See page 172 for "How to Install Mesh Cocktail Railing".

POST
SLEEVES
WILL
NEED TO
BE CUT

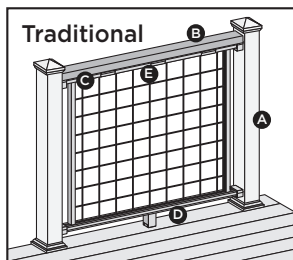

Cutting posts/post sleeves is Not required.

A. Pressure-treated post, Trex Post Mounts or Trex Joist Mount Post WITH Trex post sleeves.

NOTE: » Trex Signature Posts or Trex Signature Joist Mount Posts cannot be used.

B. 2 x 4 lateral top rail

C. Trex Signature top rail

D. Trex Signature bottom rail

E. Trex Signature Cocktail Rail Bracket**

See page 173 for "How to Install Mesh Traditional Railing".

» **NOTES:** For Signature post or pressure-treated post with post sleeve installations refer To Signature Post Installation Instructions.

** Trex Signature Cocktail Rail brackets (sold separately) are for use with either Trex Mesh Rail Traditional or Trex Mesh Rail Cocktail designs. For a 6' section, use 4 brackets and screws provided, for 8' section, use 5 brackets and screws provided.

HOW TO INSTALL HORIZONTAL MESH RAILING BRACKETS TREX SIGNATURE®

Installing Posts

REFER TO DETAILED INSTRUCTIONS ON HOW TO INSTALL TREX SIGNATURE POSTS OR PRESSURE TREATED POSTS.

NOTES:

- » FOR EASE OF INSTALLATION, IT IS RECOMMENDED TO USE THE TREX SIGNATURE RAIL TEMPLATES TO ATTACH BRACKETS (SOLD SEPARATELY).
- » TREX SIGNATURE POSTS (BLACK ONLY) CAN ALSO BE PURCHASED SEPARATELY WHICH HAVE BRACKETS PREINSTALLED, THUS SKIPPING STEPS 1-4 BELOW.

SKU NUMBER	DESCRIPTION
BKAL252537RCAPCNR	Signature Post 37" Corner Post
BKAL252537RCAPLINE	Signature Post 37" Inline Post
BKAL252543RCAPEND	Signature Post 43" End Post

SKU NUMBER	DESCRIPTION
BKAL252537RCAPEND	Signature Post 37" End Post
BKAL252543RCAPCNR	Signature Post 43" Corner Post
BKAL252543RCAPLINE	Signature Post 43" Inline Post

Attach Brackets Using Trex Signature Posts

TIP: Use a clamp to help hold brackets in place while fastening with screws.

1. Measure 1-3/8" (3.5 cm) from top of post base plate or 1-7/8" (4.8 cm) from decking surface. Mark with light line.

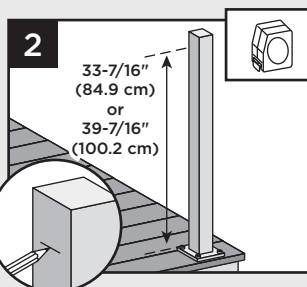
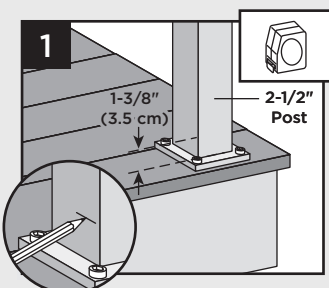

2. Measure up from post base plate 33-7/16" (84.9 cm) for 36" (92 cm) rail height or 39-7/16" (100.2 cm) for 42" (107 cm) rail height. Mark with light line.

NOTE: If measuring from decking surface, measure up 33-15/16" (86.2 cm) for 36" (92 cm) rail height or 39-15/16" (101.4 cm) for 42" (107 cm) rail height.

3. Center lower bracket on post **above** the marked line and attach using two self-tapping screws (provided).

4. Center upper bracket on post **above** marked line and attach using (3) self-tapping screws (provided).

NOTE: Upper bracket is not required on crossover post configuration.

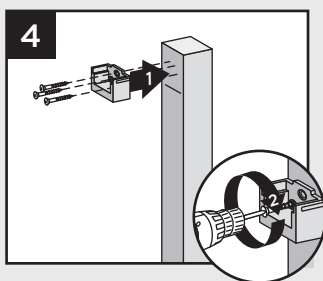

Attach Brackets Using Pressure-Treated Posts and Post Sleeves

TIP: Use a clamp to help hold brackets in place while fastening with screws.

1. Measure 1-7/8" (4.8 cm) up from deck surface to bottom of bracket. Slide skirt up to allow for proper measurement. Mark with light line.

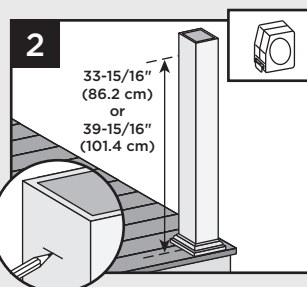
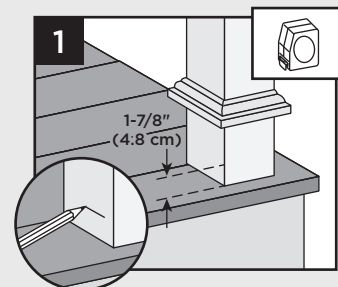

2. Measure up from decking surface 33-15/16" (86.2 cm) for 36" (92 cm) rail height or 39-15/16" (101.4 cm) for 42" (107 cm) rail height. Mark with light line.

NOTE: Push skirt back down onto surface of decking **BEFORE ATTACHING BRACKETS.**

3. Center lower bracket on post **above** the marked line and attach using two 2" (51 mm) wood screws (provided).

4. Center upper bracket on post **above** marked line and attach using three 2" (51 cm) wood screws (provided).

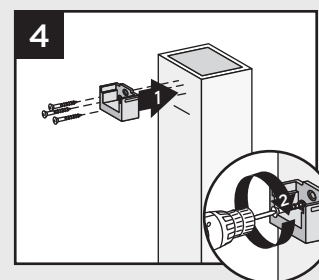

HOW TO INSTALL HORIZONTAL MESH RAILING SWIVEL BRACKETS

TREX SIGNATURE®

Attach Swivel Brackets Using Trex Signature Posts

TIP: Use a clamp to help hold brackets in place while fastening with screws.

1. Measure 1-3/8" (3.5 cm) from top of post base plate or 1-7/8" (4.8 cm) from decking surface. Mark with light line.

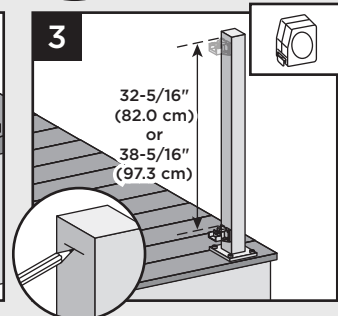
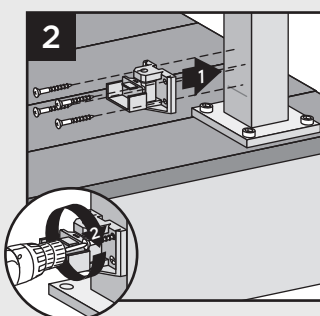
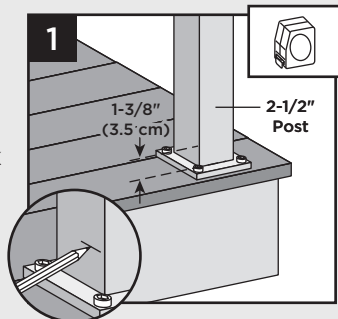

2. Center lower bracket on post **above** the marked line and attach using four self-tapping screws (*provided*).
3. Measure up 32-5/16" (82.0 cm) for 36" (91.4 cm) tall railing or 38-5/16" (97.3 cm) for 42" (106.7 cm) tall railing from top of lower rail bracket. Mark with a light line.
4. Center upper bracket on post **below** marked line and attach using four self-tapping screws (*provided*).

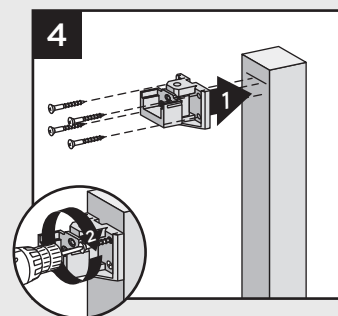

Attach Swivel Brackets Using Pressure-treated Posts and Post Sleeves

TIP: Use a clamp to help hold brackets in place while fastening with screws.

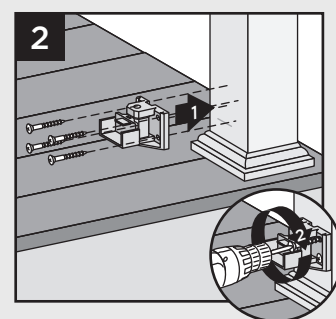
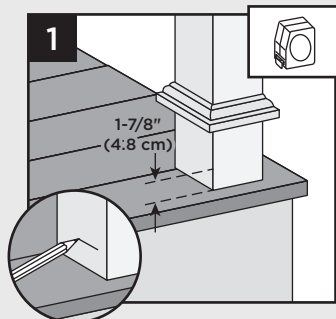

1. Measure 1-7/8" (4.8 cm) up from deck surface to bottom of bracket. Slide skirt up to allow for proper measurement, then push skirt back down onto surface of decking **BEFORE ATTACHING BRACKET**. Mark with light line.
2. Center lower bracket on post **above** the marked line and attach using four 2" (5.1 cm) wood screws (*provided*).

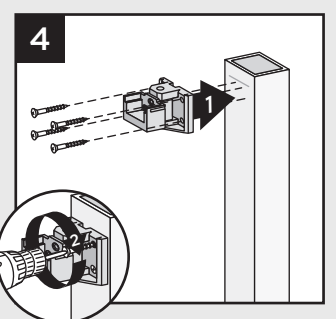
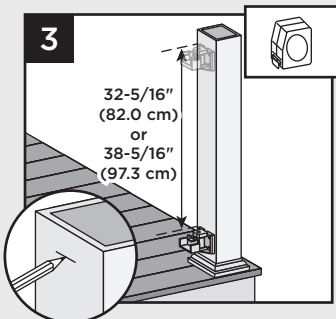

3. Measure up 32-5/16" (82.0 cm) for 36" (91.4 cm) tall railing or 38-5/16" (97.3 cm) for 42" (106.7 cm) tall railing from top of lower rail bracket. Mark with a light line.
4. Center upper bracket on post **below** marked line and attach using four 2" (5.1 cm) wood screws (*provided*).

HOW TO INSTALL HORIZONTAL MESH RAILING/CONTINUED

TREX SIGNATURE®

How to Measure and Cut Bottom and Top Rails

For Full Span Post to Post Applications - only top rail will need to be cut. For Full Span Crossover to Crossover post Applications - no rails have to be cut.

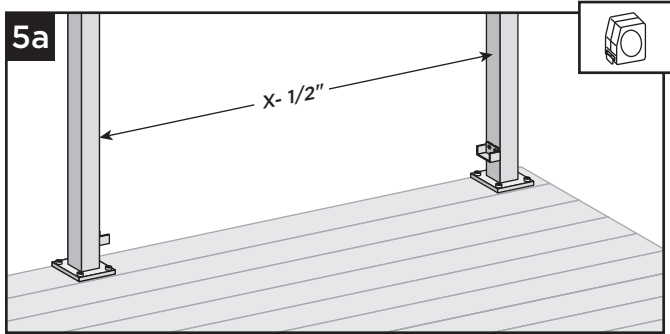

5a. Measure distance between posts (X), and subtract 1/2" for bracket clearance.

If installing crossover post configurations, adjust top rail length: $X + 3/4"$ if using one crossover post, or $X + 11/2"$ if using two crossover posts.

If using swivel brackets, measure distance between brackets and cut railings to this distance. In addition, if tabbed bottom swivel brackets are installed the tab must be removed.

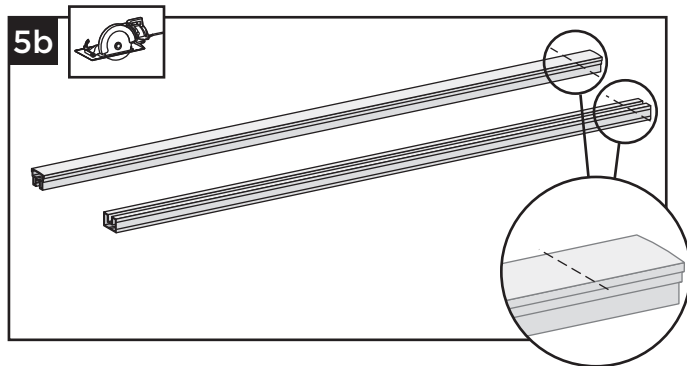

5b. Cut both bottom and top rail to length as determined above.

How to Measure and Cut Bottom and Top CURVED Rails.

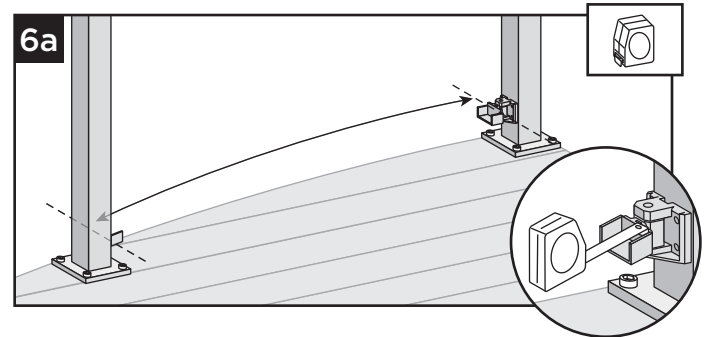

6a. With brackets in correct swivel location, measure distance from inside of bracket to inside of bracket. In addition, if tabbed bottom swivel brackets are installed the tab must be removed.

6b. Cut both curved bottom and top rails to length as determined above.

Attachment of Foot Block (One Footblock is Required for Any Length Mesh Railing Span)

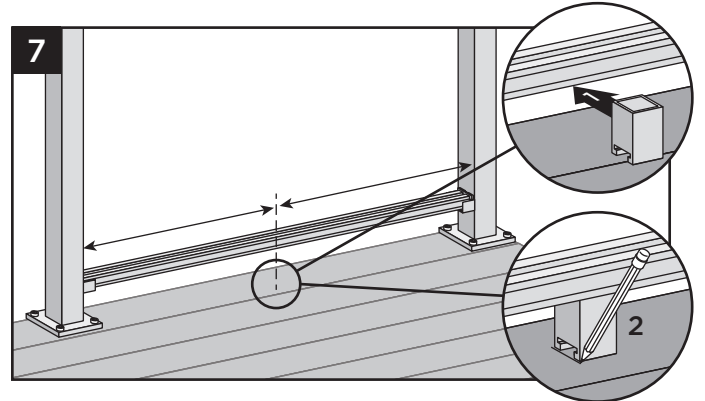

7. Temporarily place bottom rail into lower bracket. To ensure correct location, place foot block under center of bottom rail. Mark to provide placement location of base.

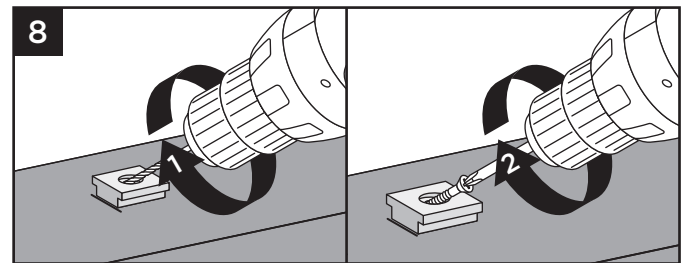

8. Remove bottom rail from lower brackets. Place base (smaller side facing down) on decking surface. Pre-drill using a 3/16" bit. Attach base of foot block using one screw at an angle through base and into decking.

HOW TO INSTALL HORIZONTAL MESH RAILING/CONTINUED

TREX SIGNATURE®

9. After attached, use a rubber mallet along with scrap piece of wood to tap foot block until it locks into place.

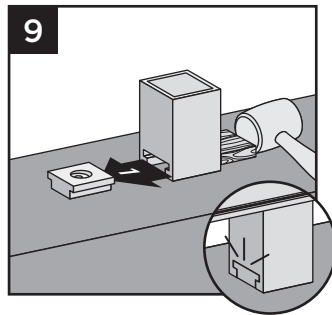

Installing Bottom Rail and Adding Weep Holes to Bottom Rail

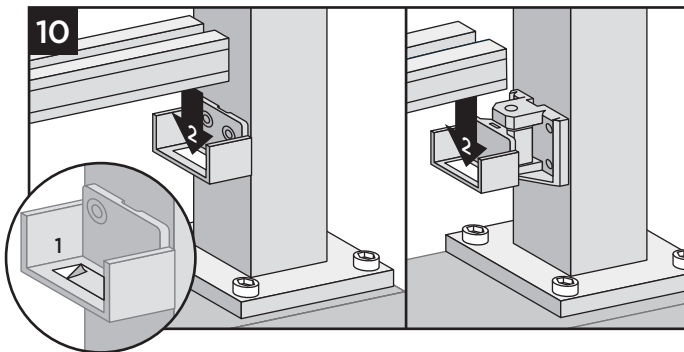

10. Place adhesive strips (provided) into bottom rail brackets, and then place bottom rail into brackets. Using a 3/8" drill bit, drill weep holes through center of bottom rail channel at 4 evenly spanned locations to allow for water drainage.

NOTE: Make sure surface is clean and dry.

Cutting Mesh (Required if installing rails at odd span lengths)

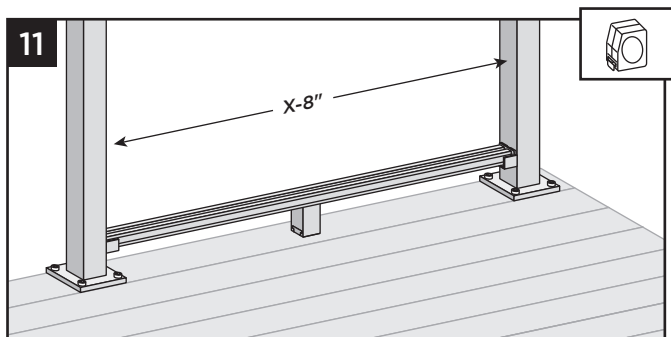

11. If not installing full span, mesh will require cutting from equal distance on each side. Measure distance between posts and subtract 8".

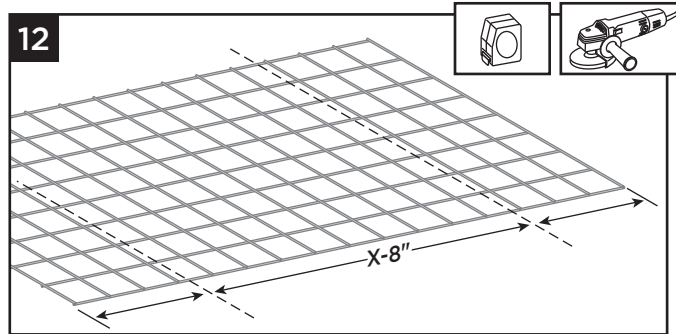

12. Cut mesh panel to this measurement, again cutting equal distances from each side so mesh is centered.

NOTE: An angle grinder (with proper blade) is recommended for cutting wire mesh. (ALWAYS USE PROPER SAFETY GEAR WHEN CUTTING WITH ANGLE GRINDER.) Note that heavy duty bolt cutters can also be used.

Cutting Bottom PVC Gasket & Installing onto Mesh

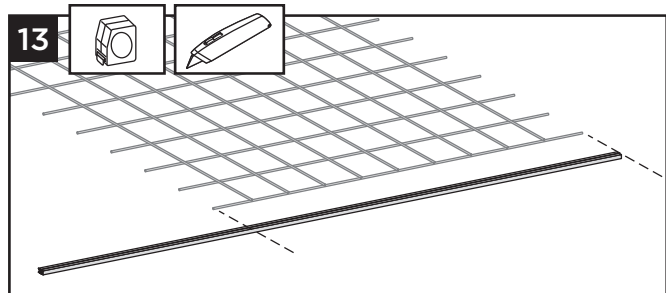

13. Cut bottom PVC gasket the same length as mesh

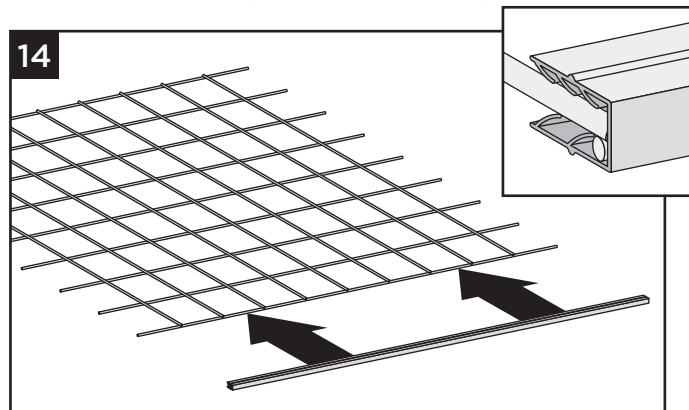

14. Install bottom PVC gasket onto bottom of mesh panel. Make sure gasket is fully seated onto mesh.

HOW TO INSTALL HORIZONTAL MESH RAILING/CONTINUED

TREX SIGNATURE®

Centering the Mesh and Installing into Bottom Rail

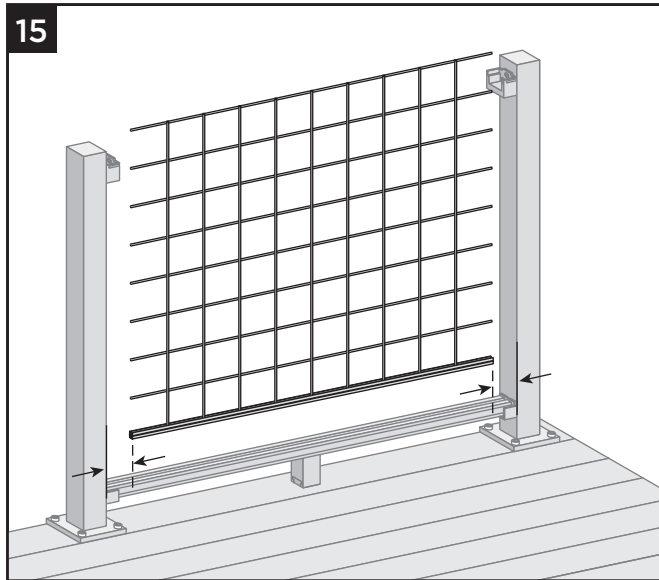

15. Center mesh (with bottom PVC gasket installed) so there is equal distance between sides of mesh and posts.

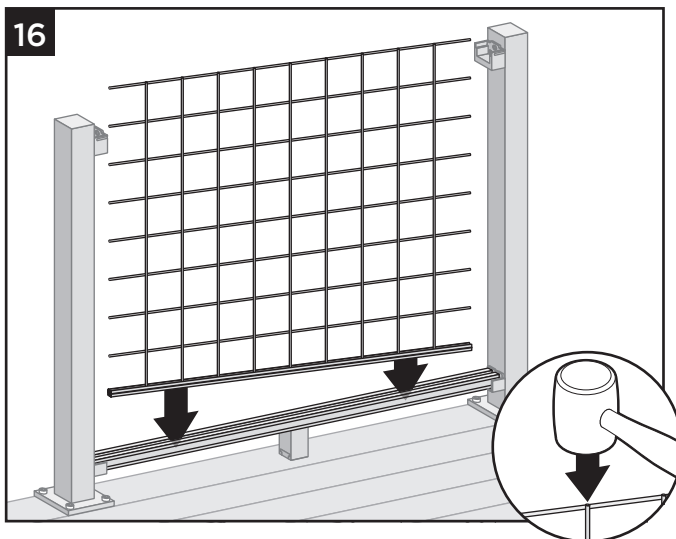

16. Starting at one end, push mesh (with bottom PVC gasket installed) firmly into the bottom rail. GENTLE tapping with rubber mallet on mesh CROSS-SECTIONS will help prevent mesh from bending.

NOTE: Make sure mesh is being secured by hand until final assembly of the top rail.

Installing Vertical PVC Gaskets onto Mesh (No cutting required these come standard size.)

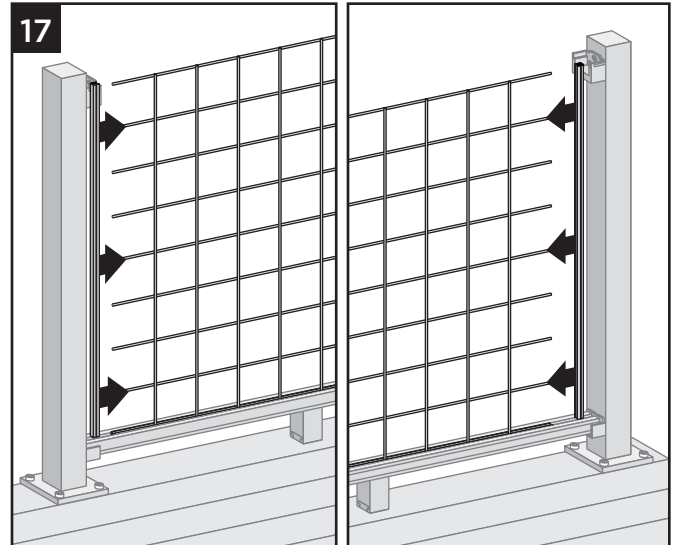

17. Install vertical PVC gaskets onto each side of mesh, ensuring that bottom of gaskets are resting on surface of bottom rail. Make sure that gaskets are fully seating onto the mesh.

Installing L-Brackets into Vertical Supports

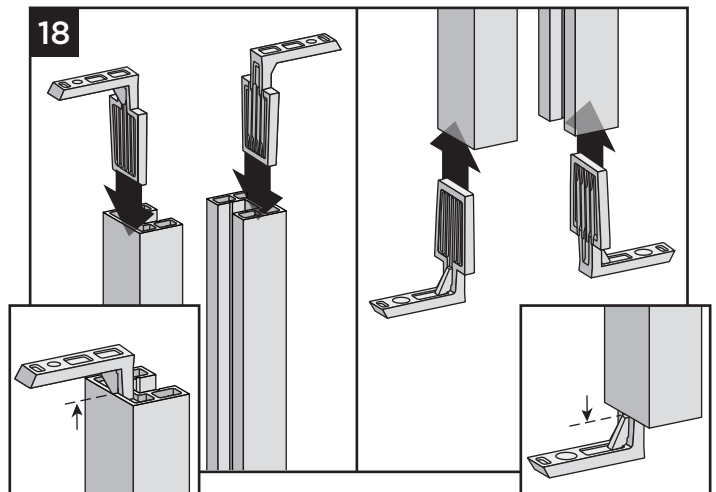

18. Install L-brackets into both top and bottom slots of vertical supports as shown. L-brackets will require light tapping until stop lip of bracket is resting on vertical support.



HOW TO INSTALL HORIZONTAL MESH RAILING/CONTINUED

TREX SIGNATURE®

Installing Vertical Supports

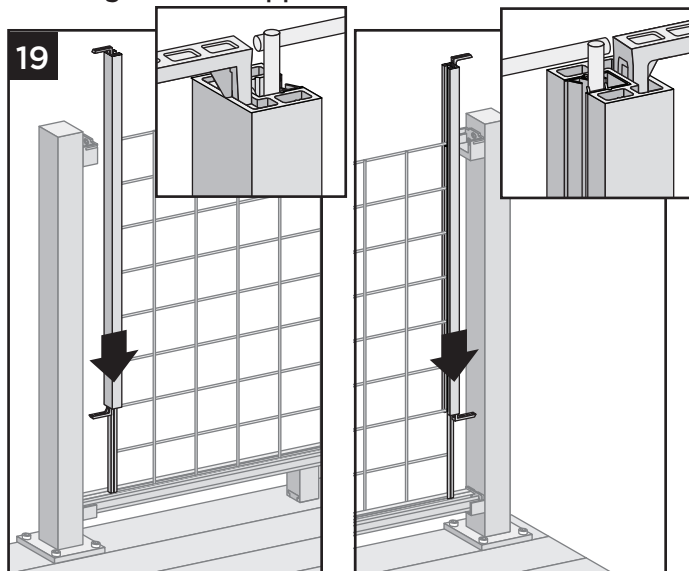

19. Install vertical supports onto vertical PVC gaskets, also ensuring that L-bracket is fully seated into bottom rail channel. Light tapping with rubber mallet may be required.

Cutting Top PVC Gasket & Installing onto Mesh

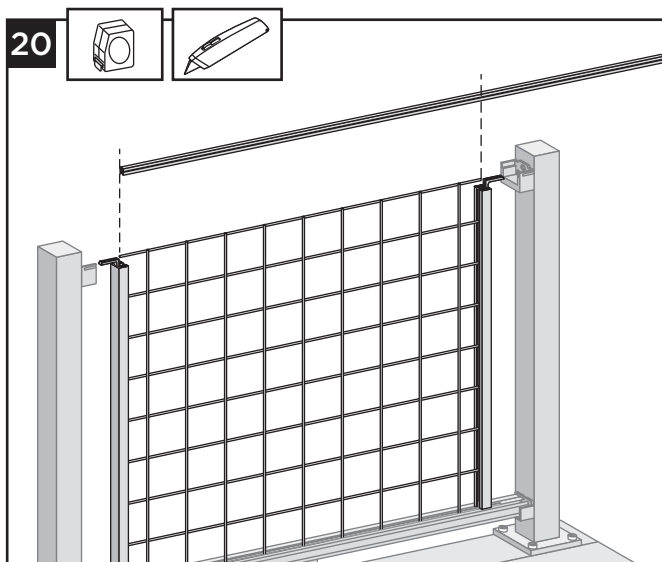

20. Cut top PVC gasket the same length as mesh panel.

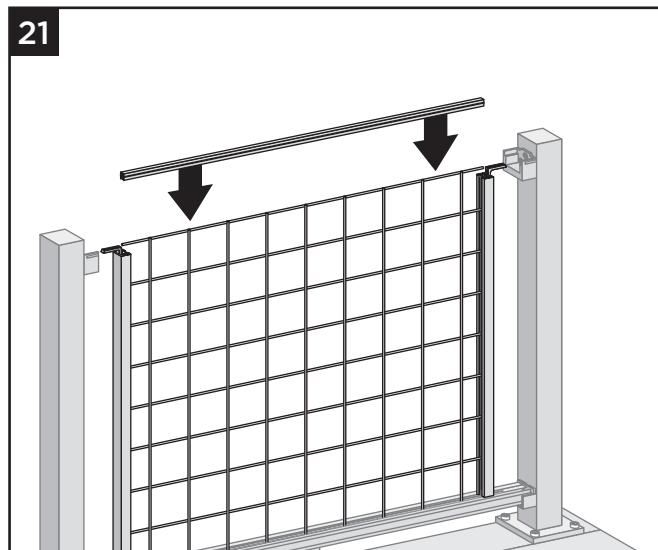

21. Install cut gasket onto top of mesh panel. Make sure gasket is fully seated onto mesh.

Installing Top Rail onto Mesh Panel

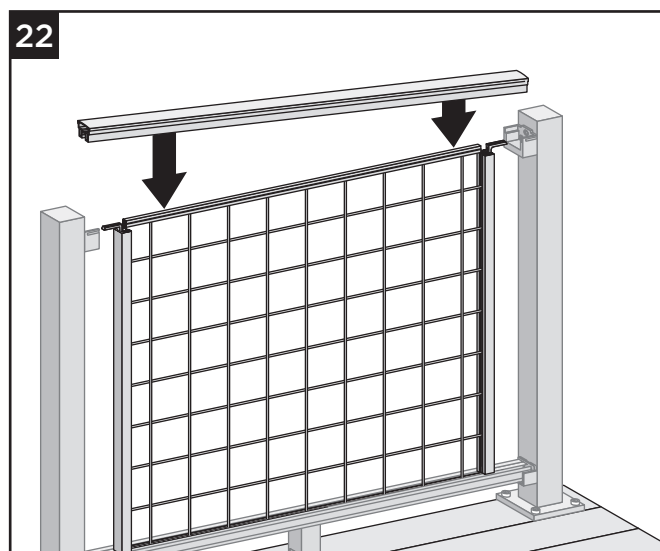

22. Starting at one end and working down, press the top rail firmly onto the top of the mesh panel (with top PVC gasket on mesh). Ensure the top rail is centered properly so top rail will seat into brackets when finished.

HOW TO INSTALL HORIZONTAL MESH RAILING/CONTINUED

TREX SIGNATURE®

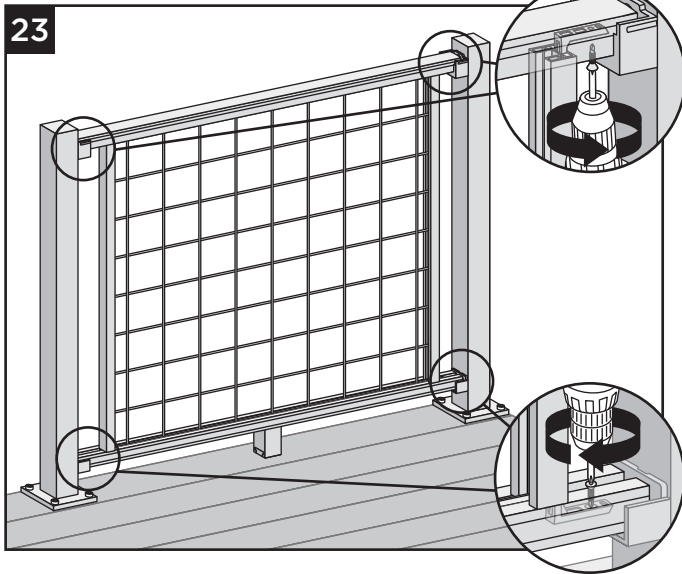

Attaching L-Brackets to Top and Bottom Rails
 23. Attach L-Brackets to both top and bottom rails using one #8 x 5/8 flat head screw (provided).

Attaching Top Rail to Brackets

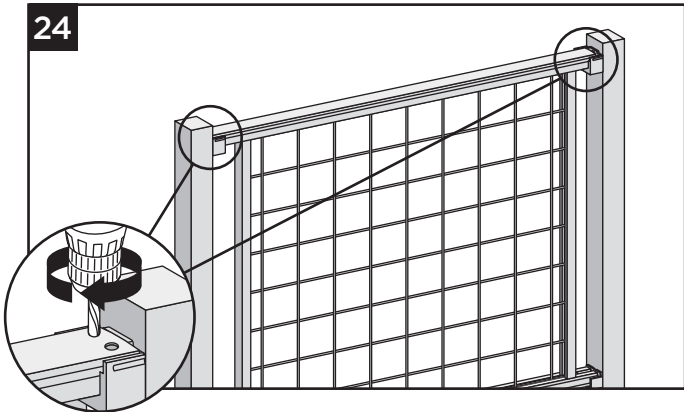

24. Drill two 1/2" holes approximately 1/2" from end of top rail. Repeat this on opposite side of top rail.

IMPORTANT NOTES:

- » HOLES CANNOT EXTEND PAST BRACKET, OTHERWISE BRACKET COVER WILL NOT COVER HOLES.
- » ONLY DRILL 1/2" HOLES THRU TOP WALL OF TOP RAIL. DO NOT USE A STEP BIT.

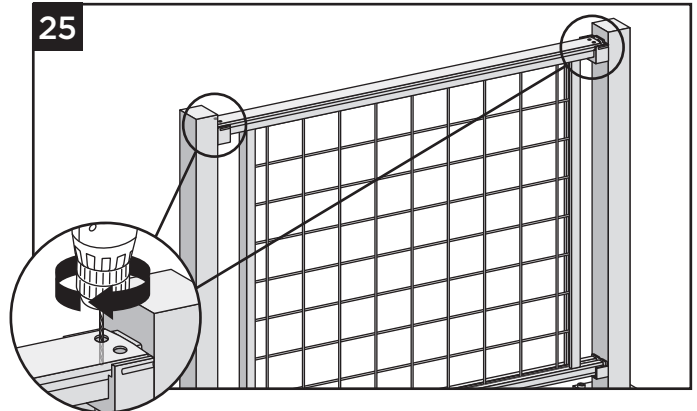
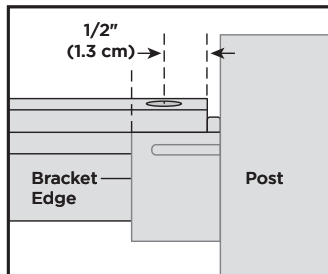

25. Using 9/64" bit provided, center into above holes and **PREDRILL** into top rail bracket at a depth of approximately 1-1/4". Use care to not drill through underside of top bracket.

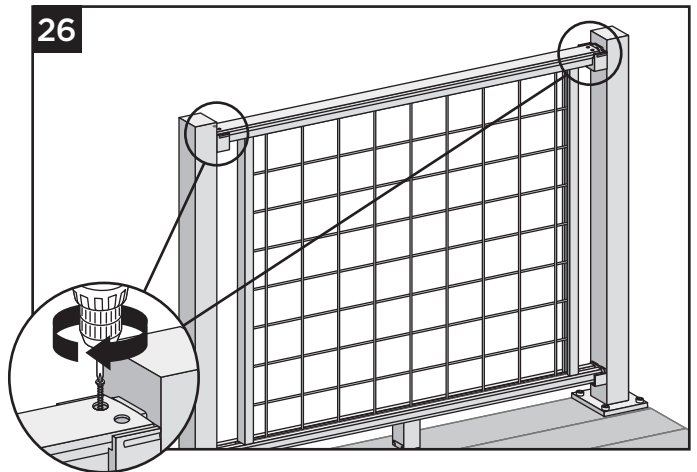
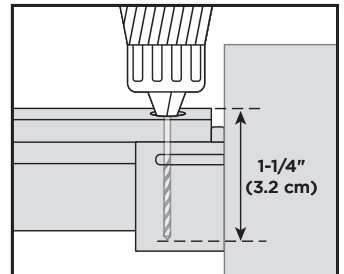

26. Install two #8 x 1-1/4" screws provided into top rail and top bracket on each end of top rail.



HOW TO INSTALL HORIZONTAL MESH RAILING/CONTINUED

TREX SIGNATURE®

Installing Snap-in Channel Filler

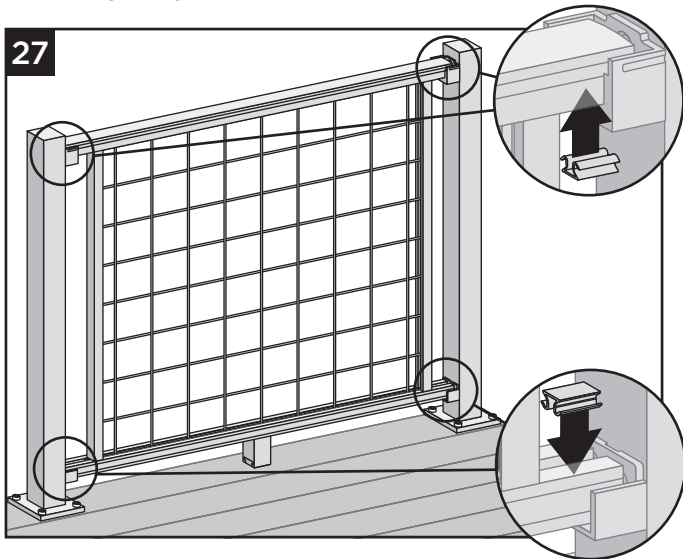

27. Cut snap-in channel filler to correct length and install into channels of bottom and top rails. Use of a rubber mallet may assist with this step. **DO NOT** attempt to cut short snap in pieces with a miter saw. Use an angle grinder or hack saw only.

Attachment of Bracket Covers, Skirts, and Caps

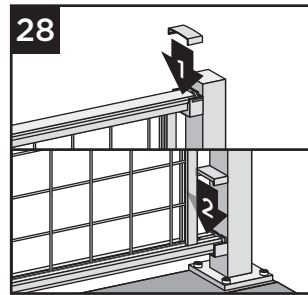

28. Attach corresponding bracket covers over opening in upper and bottom rails.

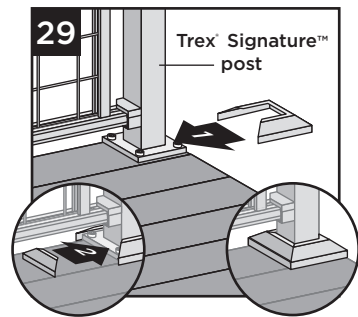

29. Attach provided post skirt to bottom of posts when using Trex Signature posts.

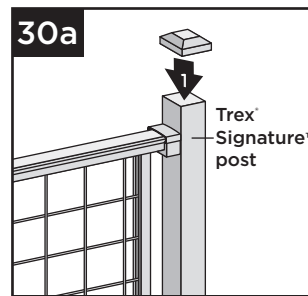

30a. Attach post caps to Trex Signature posts. (Use of **rubber mallet** may be required for secure attachment.)

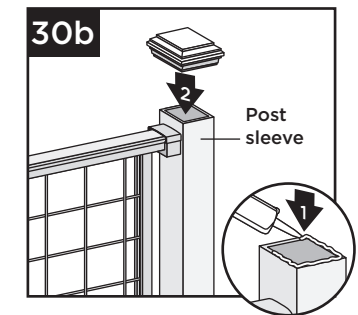

30b. Attach post caps to post sleeves using external grade PVC construction adhesive (apply adhesive on the inside self-centering/corner tabs).

HOW TO INSTALL MESH COCKTAIL RAILING

TREX SIGNATURE®

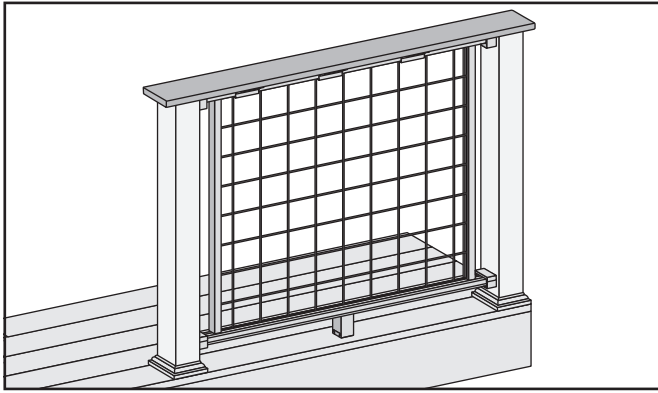

IMPORTANT NOTE:

- » **ONLY** for use with pressure treated 4 x 4 post (3.5" nominal square) and 4" x 4" (102 mm x 102 mm) post sleeve. Trex Signature® posts, Trex post mounts or joist mount posts cannot be used with Trex Mesh Cocktail railing. Cutting post and post sleeve **ONLY** applies to the Cocktail style railing.

Installing Pressure-treated Posts, Post Sleeves, and Skirts to Use with Mesh Cocktail Railing

NOTE: PLEASE REFER TO LOCAL BUILDING CODE REQUIREMENTS PRIOR TO ATTACHING PRESSURE TREATED POSTS. BELOW INSTRUCTIONS ARE GUIDELINES FOR GENERAL REQUIREMENTS.

- 1a. Attach posts using 1/2" (13 mm) carriage bolts.
 - » Minimum joist size is 2" x 8" (51 mm x 203 mm).
 - » Top bolts must be 1" (25 mm) from top of joists.
 - » Bottom bolts must be 5-1/8" (130 mm) from top bolts.

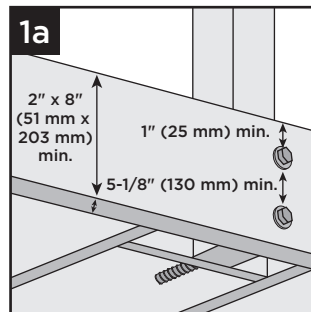

NOTE: Blocking can be added for extra strength.

- 1b. Slide post sleeve skirt over post and down to rest on decking surface. Slide post sleeve over post and position inside post sleeve skirt.

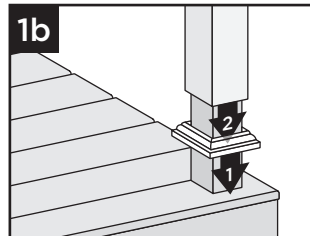

NOTE: Shims can be used to plumb post sleeves.

Cutting Post and Post Sleeve

2. Mark and cut post and post sleeve measuring from deck surface:
 - » 36-1/32" (915 mm) for 36" (914 mm) height.
 - » 42-1/32" (1068 mm) for 42" (1067 mm) height.

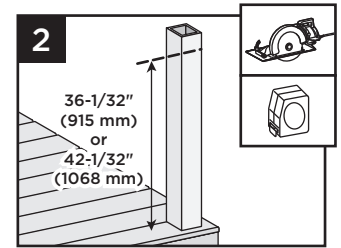

3. How to Measure Bottom and Top Rails

See instructions on page 166.

4. Cutting Rails

See instructions on page 166.

5. Attachment of Foot Block (REQUIRED)

See instructions on page 166.

6. Installing Bottom Rail and Adding Weep Holes to Bottom Rail

See instructions on page 167.

7. Cutting Mesh (if required)

See instructions on page 167.

8. Cutting Bottom PVC Gasket and Installing onto Mesh

See instructions on page 167.

9. Centering Mesh and Installing into Bottom Rail

See instructions on page 168.

10. Installing Vertical PVC Gaskets onto Mesh

See instructions on page 168.

11. Installing L-Brackets into Vertical Supports

See instructions on page 168.

12. Installing Vertical Supports

See instructions on page 169.

13. Cutting Top PVC Gasket and Installing onto Mesh

See instructions on page 169.

14. Installing Top Rail onto Mesh Panel

See instructions on page 169.

15. Attaching L-Brackets to Top and Bottom Rails

See Instruction on page 170.

16. Attaching Top Rail to Brackets

See instructions on page 170.



HOW TO INSTALL MESH COCKTAIL RAILING/ CONTINUED TREX SIGNATURE®

17. Installing Snap-in Channel Filler

See instructions on page 171.

NOTE: Top Bracket Covers are not attached in this configuration.

Attaching Deck Board to Top Rail

18. Place deck boards (**DO NOT** use Enhance deck boards for top rail) over top rails. Attach boards on each post with Trex-recommended composite screws (quantity of 2 per each post/board end).

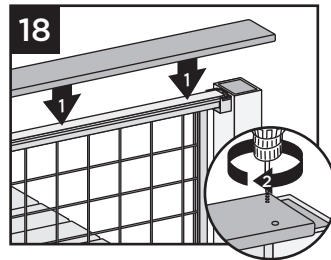

19. Secure boards to top rail using Trex Signature Cocktail Bracket (sold separately). Ensure that there is a bracket at each end of the railing section, then space brackets approximately every 24" and attach with 4 screws provided.

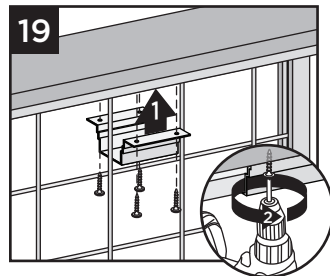

NOTE: Pre-drilling before attachment is recommended.

20. Use scarf cut for posts where two deck boards meet.

NOTES:

- » Leave 1/8" (3 mm) gap between deck boards.
- » Deck boards can overhang end of last post maximum 1/2" (13 mm).

21. Attachment of Bottom Bracket Covers

See instructions on page 171.

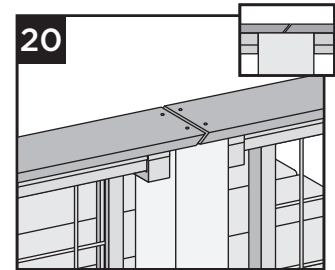

HOW TO INSTALL MESH TRADITIONAL RAILING TREX SIGNATURE®

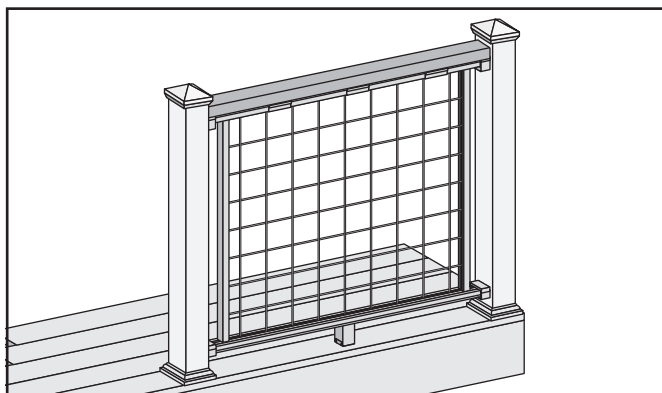

Important: Only use with Pressure-treated post, Trex Post Mounts or Trex Joist Mount Post WITH Trex post sleeves. Trex Signature Posts and Joist Mount Posts cannot be used with Mesh Traditional.

1. Installing Posts, Post Sleeves, and Skirts

See instructions on page 176 for pressure treated posts. Refer to detailed Trex Post Mount instructions if using these. Post and Post Sleeves are **NOT CUT** in this installation.

2. How to Measure Bottom and Top Rails

See instructions on page 166.

3. Cutting Rails

See instructions on page 166.



HOW TO INSTALL MESH TRADITIONAL RAILING TREX SIGNATURE®

4. Attachment of Foot Block (REQUIRED)

See instructions on page 166.

5. Installing Bottom Rail and Adding Weep Holes to Bottom Rail

See instructions on page 167.

6. Cutting Mesh (if required)

See instructions on page 167.

7. Cutting Bottom PVC Gasket and Installing onto Mesh

See instructions on page 167.

8. Centering Mesh and Installing into Bottom Rail

See instructions on page 168.

9. Installing Vertical PVC Gaskets into Mesh

See instructions on page 168.

10. Installing L-Brackets into Vertical Supports

See instructions on page 168.

11. Installing Vertical Supports

See instructions on page 169.

12. Cutting Top PVC Gasket and Installing onto Mesh

See instructions on page 169.

13. Installing Top Rail onto Mesh Panel

See instructions on page 169.

14. Attaching L-Brackets to Top and Bottom Rails

See instructions on page 170.

15. Attaching Top Rail to Brackets

See instructions on page 170.

16. Installing Snap-in Channel Filler

See instructions on page 171.

NOTE: Top Bracket Covers are not attached in this configuration.

Attaching 2 x 4 to Top Rail

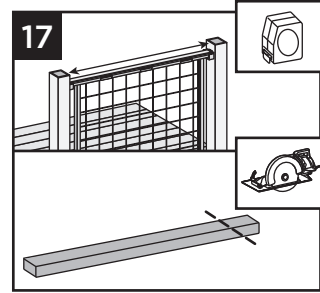

17. Measure between posts and cut 2 x 4 to length.

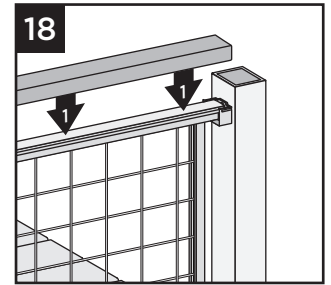

18. Place 2 x 4 on Trex Signature top rail.

19. Secure 2 x 4 to top rail using Trex Signature Cocktail Bracket (sold separately). Ensure that there is a bracket at each end of the railing section, then space brackets approximately every 24" and attach with 4 screws provided.

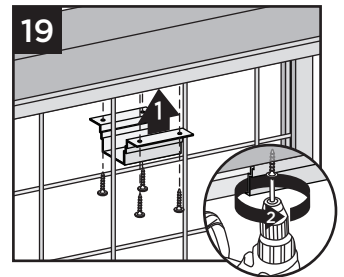

NOTE: Pre-drilling before attachment is recommended.

20. Pre-drill and toenail 2-1/2" (6.4 cm) approved deck screw at each end of 2 x 4 into post on back side of rail (side not facing decking).

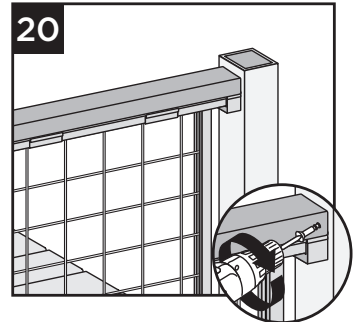

21. Attachment of Bottom Bracket Covers and Caps

See instructions on page 171.

MESH STAIR RAILING

TREX SIGNATURE®

DUE TO THE COMPLEXITY OF THIS PRODUCT, INSTALLATION OF SIGNATURE MESH STAIR RAIL WILL REQUIRE THE USE OF QUALIFIED AND KNOWLEDGABLE CONTRACTORS IN MOST CASES.

HOW TO INSTALL TREX SIGNATURE STAIR POSTS AND STAIR RAILING

TOOLS NEEDED

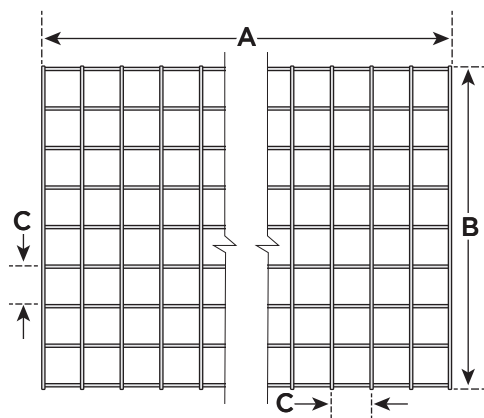
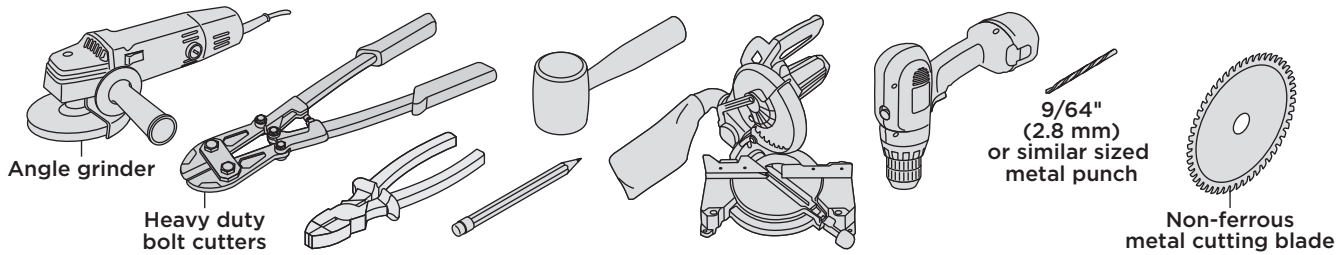

MESH DIMENSIONS CHART			
Panel Size	A	B	C
6' x 36" HZ	64"	32 3/8"	4"
8' x 36" HZ	88"	32 3/8"	4"
8' x 42" HZ	88"	38 3/8"	4"
8' x 42" ST	108 3/16"	36 3/16"	4"

Stair Post Spanning and Angle Placement Charts

42" STAIR GUARDRAIL					
Use HZ Panel Size	Max Post Spacing Based on Stair Angle				
	30°	32°	34°	37°	38°
6' x 36" HZ	NA	NA	42"	40"	39"
8' x 36" HZ	NA	NA	62"	59"	58"
8' x 42" HZ	66"	65"	62"	59"	58"
Use Stair Panel Size	Max Post Spacing				
	30°	32°	34°	37°	38°
36 3/16" x 108 3/16" ST	72"	72"	72"	72"	72"

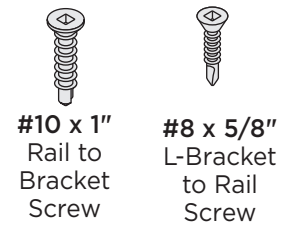

36" STAIR GUARDRAIL					
Use HZ Panel Size	Max Post Spacing Based on Stair Angle				
	30°	32°	34°	37°	38°
6' x 36" HZ	46"	45"	42"	40"	39"
8' x 36" HZ	67"	65"	62"	59"	58"
8' x 42" HZ	67"	65"	62"	59"	58"
Use Stair Panel Size	Max Post Spacing				
	30°	32°	34°	37°	38°
36 3/16" x 108 3/16" ST	72"	72"	72"	72"	72"

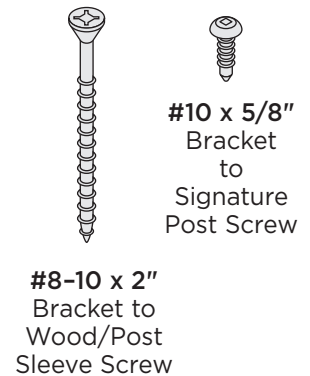

HOW TO INSTALL MESH STAIR POSTS TREX SIGNATURE®

IMPORTANT NOTES:

- » FOR A 6' OR 8' STAIR RAIL, POST TO POST SPAN WILL BE LESS THAN 6' OR 8'. PRIOR TO INSTALLING STAIR POSTS CALCULATE POST TO POST SPAN USING A MAXIMUM STAIR RAIL LENGTH REQUIRED AND THE ANGLE (32°-37°) AT WHICH THE STAIR RAILS WILL BE INSTALLED. DO NOT INSTALL STAIR POSTS AT 6' OR 8' SPAN, AS STAIR RAILINGS WILL THEN BE TOO SHORT.
- » TREX SIGNATURE POSTS CANNOT BE USED WITH TREX SIGNATURE COCKTAIL STAIR MESH OR TRADITIONAL STAIR MESH DESIGNS, ONLY PRESSURE-TREATED POST/POST SLEEVES CAN BE USED. REFER TO DETAILED INSTRUCTIONS FOR MORE INFORMATION.
- » All stair installations require the use of 53" (134.6 CM) stair post, measured and cut to appropriate length if required.
- » All Trex Signature fixed stair brackets ONLY work with stair slopes of 32°-37°.
- » A FOOTBLOCK IS REQUIRED FOR ALL SPANS OF TREX SIGNATURE MESH RAIL. FOOT BLOCKS ARE SOLD SEPERATELY.

Installing Standard Trex Signature Stair Posts, or Pressure-treated Post, Post Sleeves and Skirts

1. Make sure 53" (135.6 cm) posts are used for all stair posts.

2. If Trex Signature stair posts are used, install at nose of stair tread directly under required blocking. See *Trex Signature horizontal post instructions*.

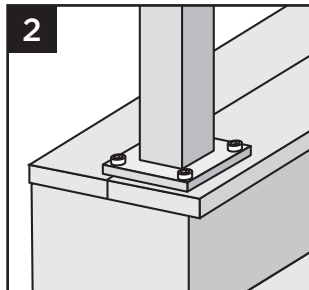

Installing Pressure-Treated Posts

- » PLEASE REFER TO LOCAL BUILDING CODE REQUIREMENTS PRIOR TO ATTACHING PRESSURE TREATED POSTS.
- » PRESSURE TREATED POSTS MUST BE INSTALLED ON INSIDE OF STAIR STRINGER AND AT NOSE OF STAIR TREAD.
- » POST TO POST SPAN WILL BE LESS THAN 6' OR 8'. PRIOR TO INSTALLING POSTS CALCULATE POST TO POST SPAN USING A MAXIMUM RAIL LENGTH REQUIRED AND THE ANGLE (32°-37°) AT WHICH THE RAILS WILL BE INSTALLED. DO NOT INSTALL STAIR POSTS AT 6' OR 8' SPAN, AS STAIR RAILINGS WILL THEN BE TOO SHORT.
- » Attach posts using code approved hardware and also use added blocking.
- » Bolts can be countersunk flush with framing to allow for fascia attachment.
- » In most cases, a post and post sleeve longer than 39" will be needed on the lower section of stair rail to accommodate stair angle.

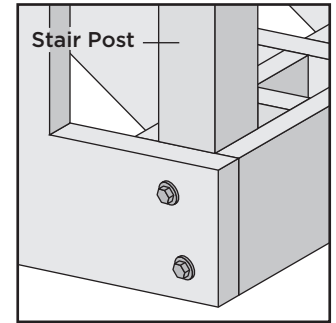

NOTE: Blocking can be added for extra strength.

BRACKET HARDWARE - STAIR APPLICATIONS TREX SIGNATURE®

- AA. Bottom Stair Bracket and Cover - Lower Rail
- BB. Top Stair Bracket and Cover - Lower Rail
- CC. Fastener Pack
- DD. Bottom Stair Bracket and Cover - Upper Rail
- EE. Top Stair Bracket and Cover - Upper Rail

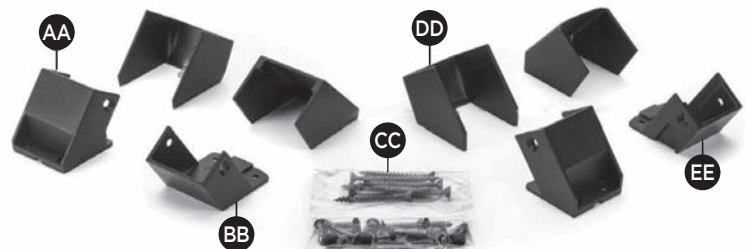

HOW TO INSTALL MESH STAIR RAILING

TREX SIGNATURE®

Measuring and Cutting Rails

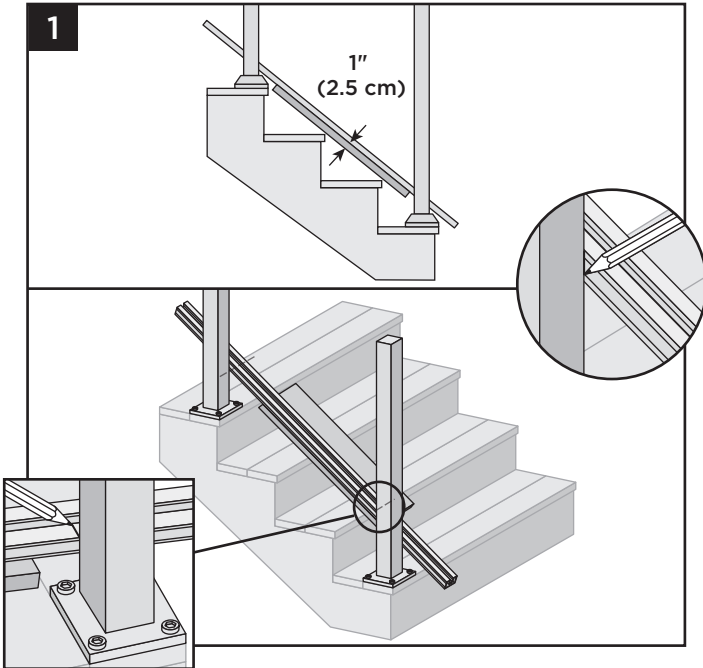

1. Place a 1" deck board along the nose of the stair tread, then lay the bottom stair rail on top of the deck board. Use the lower and upper stair post to determine the length of the bottom stair rail. At **LOWER STAIR POST**, mark on topside of rail and cut PERPENDICULAR to the rail. At **UPPER STAIR POST**, mark on INTERSECTION/SIDE OF RAIL AND CUT RAIL TO THIS ANGLE.

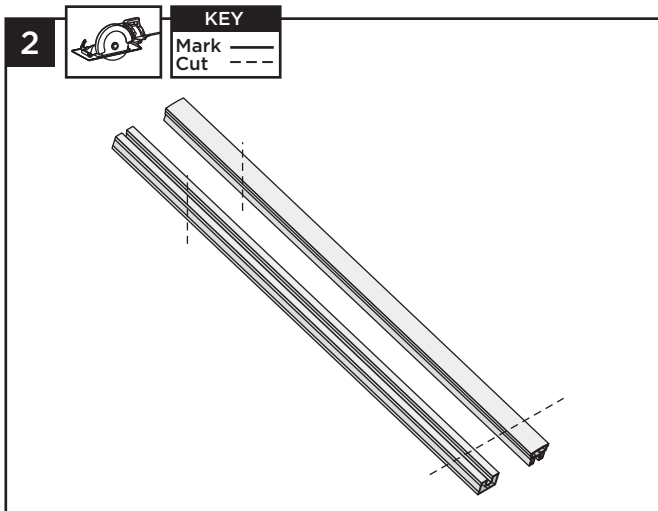

2. Cut both bottom and top rails to same length. ENSURE POSTS ARE PLUMB before cutting.

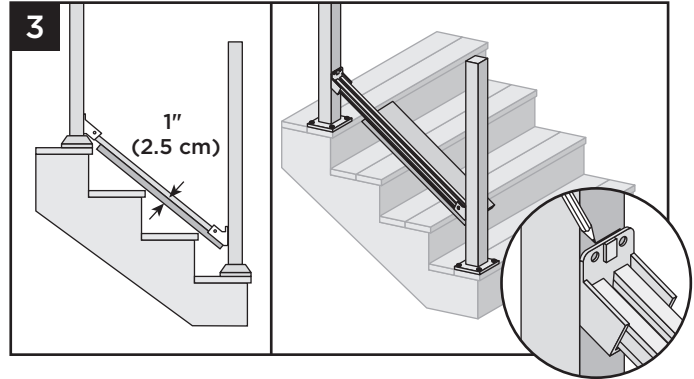

3. With deck board still on nose of stair tread, place brackets on ends of bottom stair rail (but do not attach) and mark posts for bracket locations.

Installing Lower Stair Brackets

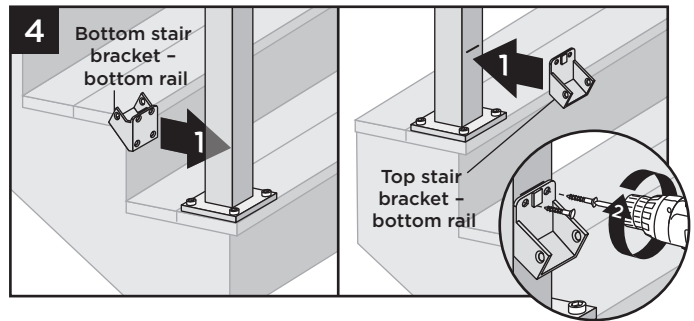

4. Center lower stair bracket on post below the marked line and attach using two #10 x 5/8" self-tapping screws (provided). In some cases it may be difficult to attach the stair bracket on the lower stair post. Recommend using a 90° drill adapter or loosen the post to get access to the lower bracket screw holes.

Installing Upper Stair Brackets

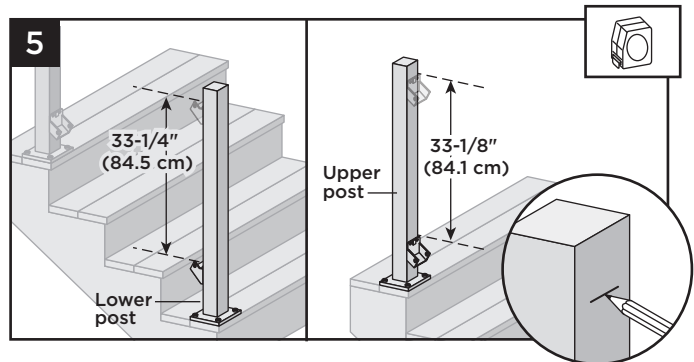

5. On Lower Post: From top of lower bracket, measure up and mark with light line (33-1/4" for 36" rail; 39-1/4" for 42" rail). On Upper Post: From top of lower (upper) bracket, measure up and mark with light line (33-1/8" for 36" rail; 39-1/8" for 42" rail).

HOW TO INSTALL MESH STAIR RAILING/CONTINUED

TREX SIGNATURE®

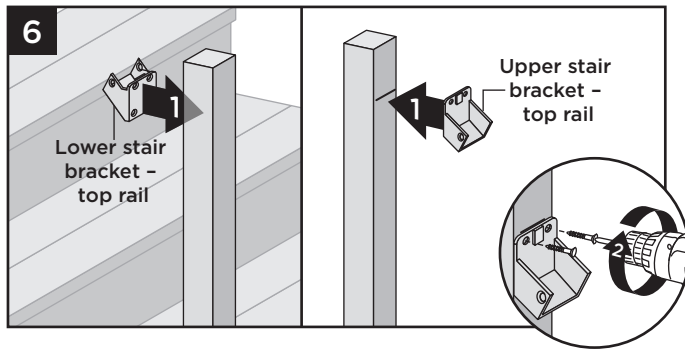

6. Center upper stair brackets on posts **below** the marked lines and attach using two #10 x 5/8" self-tapping screws (*provided*).

Attachment of Foot Block

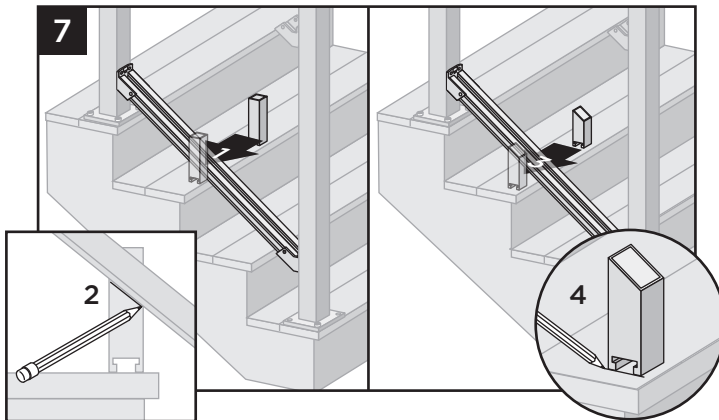

7. Temporarily set bottom stair rail into brackets. To ensure proper location place foot block towards the nose of the stair tread along the side of the bottom rail. Mark location of angle on foot block and cut on mark. Then place foot block under the center of the bottom rail. Mark placement location of the base.

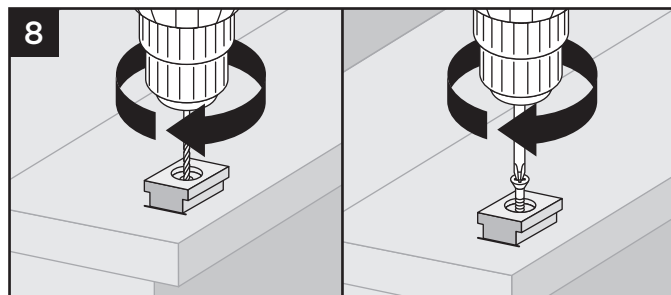

8. Place base (smaller side facing down) on decking surface. Pre-drill using a 3/16" bit. Attach base of foot block using one screw at an angle through base and into decking.

9. After attached, use a **rubber mallet along with scrap piece of wood** to tap foot block until it locks into place.

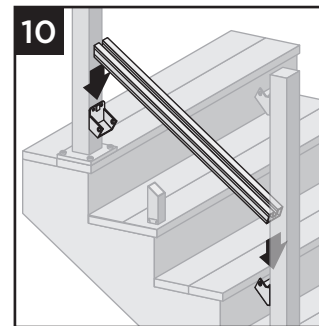
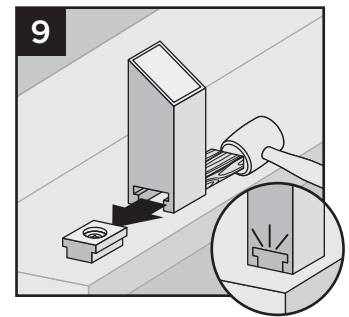

10. Set bottom stair rail into bottom stair rail brackets.
11. Set top stair rail into top stair rail brackets.

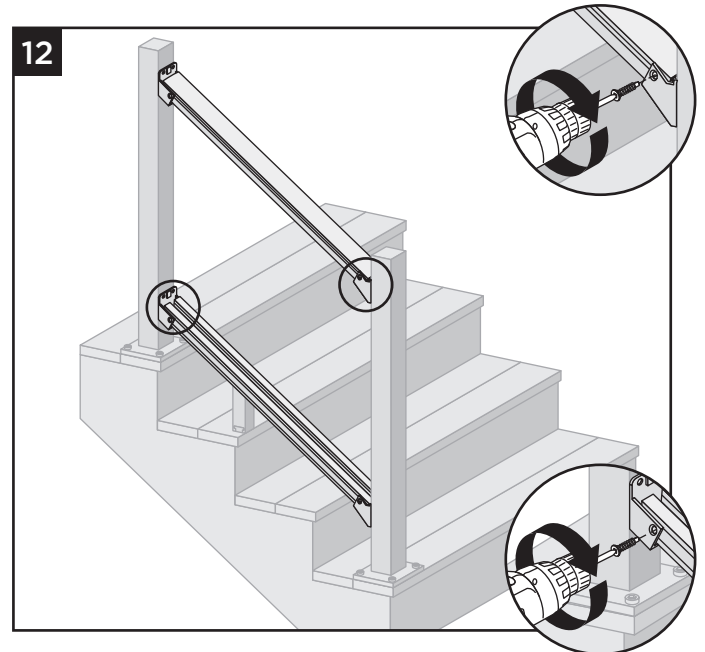
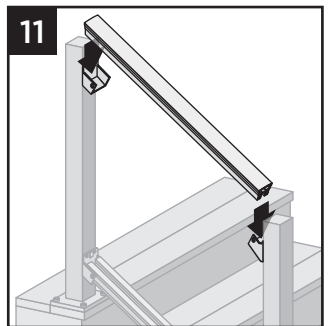

12. **TEMPORARILY ATTACH BOTH BOTTOM AND TOP RAIL (IN ONE LOCATION ONLY TO ENSURE RAILS DO NOT MOVE) USING ONE #10 X 1" SELF-TAPPING SCREW (PROVIDED) ON SIDE OF BRACKET. YOU MUST PREDRILL THIS LOCATION FIRST USING 9/64" BIT THAT WAS PROVIDED IN HORIZONTAL MOUNTING KITS.**

HOW TO INSTALL MESH STAIR RAILING/CONTINUED

TREX SIGNATURE®

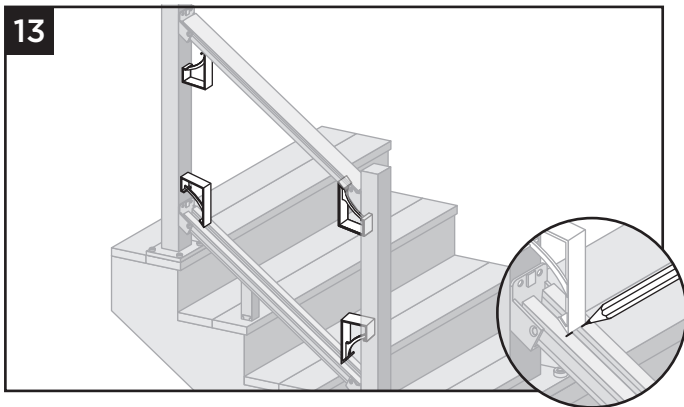

13. Using the long edge of the stair template, mark the location of the end verticals on the upper and lower rails.

NOTE: Mark should only be 1" max length or it will be visible after installation of vertical.

Measuring and Cutting Rail Gaskets

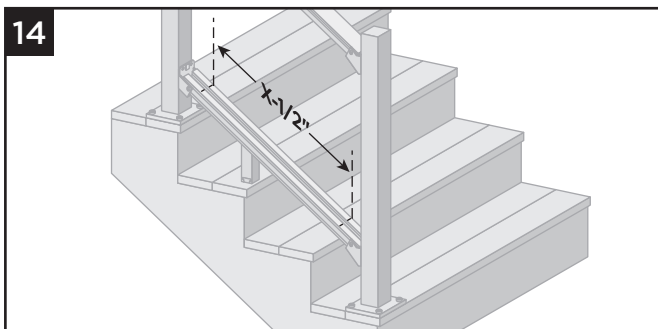

14. Measure distance between marked lines on bottom rail and subtract 1/2" from this measurement.

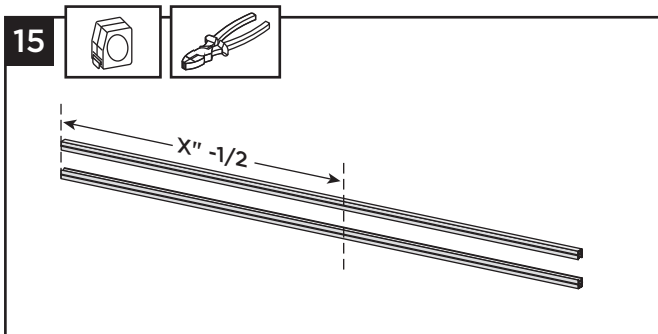

15. Cut both bottom and top rail gaskets to length from previous step.

Measuring Verticals

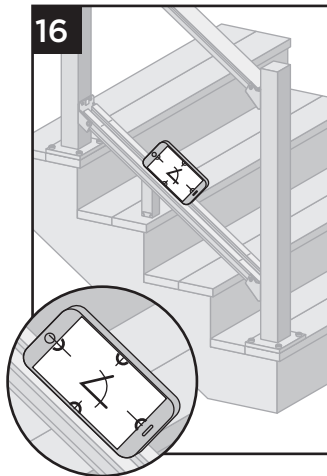

16. Determine the angle of the railing (angle should be between 32-37 degrees).

NOTE: This can easily be done with using an angle measurement app on cellular phone or using a speed square.

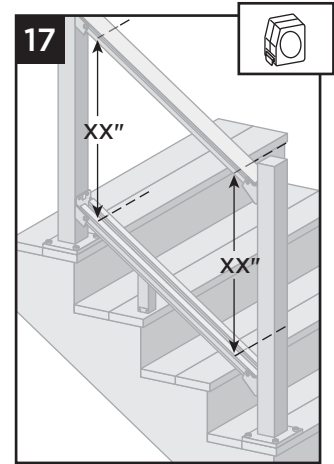

17. Measure distance between marks from bottom to top rail.

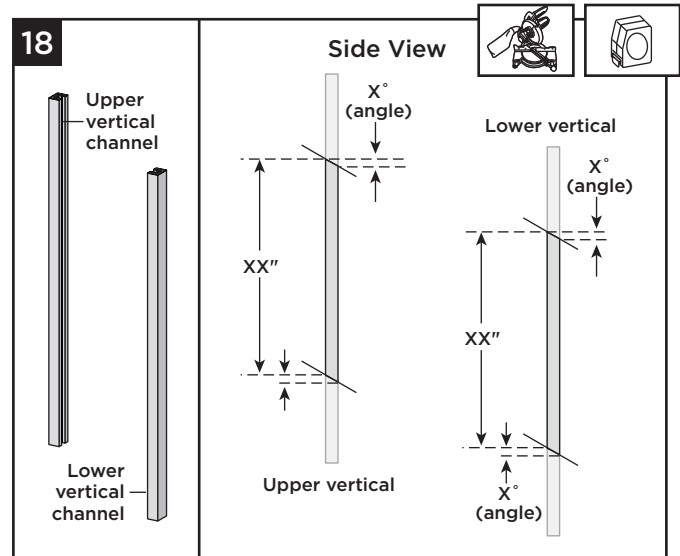

18. Ensure the verticals are oriented in the correct location, with the channels facing toward each other. Cut verticals to the dimension and at the angle provided above.

HOW TO INSTALL MESH STAIR RAILING/CONTINUED

TREX SIGNATURE®

L-BRACKET ORIENTATION

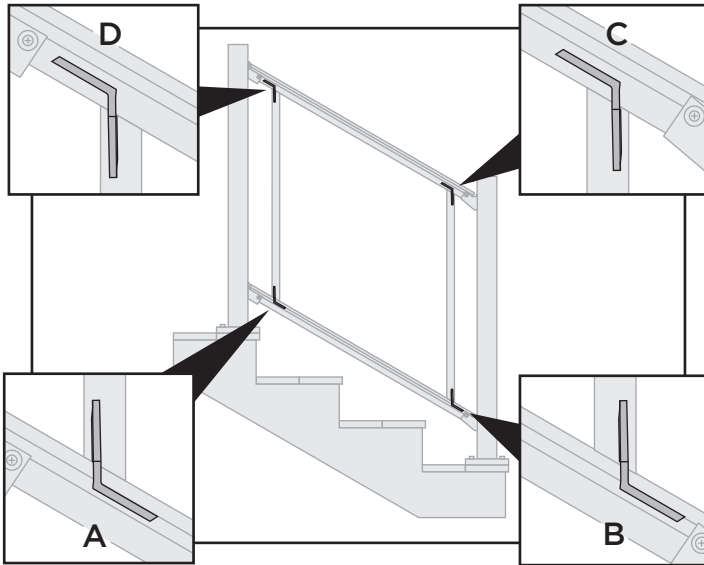

Above is an overall image showing bracket orientation. The next steps will show in detail how to attach them. Refer to corresponding letters in the following steps.

A-Bottom Rail TOP POST LOCATION

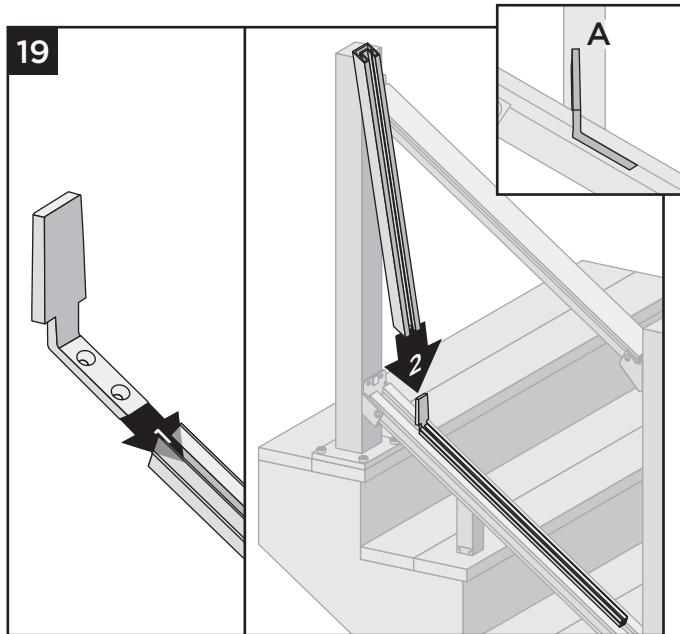

Installing Gaskets and L-Brackets

19. At **TOP POST LOCATION**, slide L-bracket into end of gasket. Place gasket so it's resting on the top of the channel (do not insert gasket fully into channel). Slide vertical onto L-bracket.

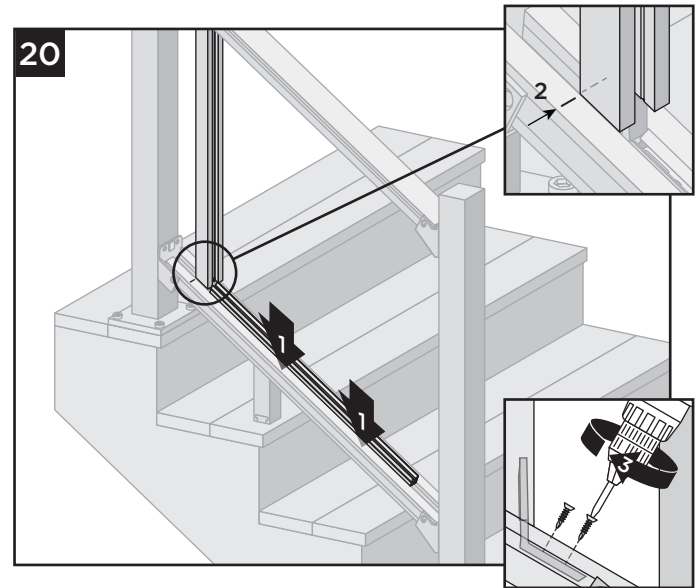

20. Gently tap gasket into channel of bottom rail. Make sure that upper vertical is properly aligned with mark on bottom rail to ensure this is seated in correct location **BEFORE** attaching L-bracket. Attach L-bracket to bottom rail with two #8 x 5/8" flat head screws (*provided*).

B-Bottom Rail BOTTOM POST LOCATION Measuring for L-Brackets

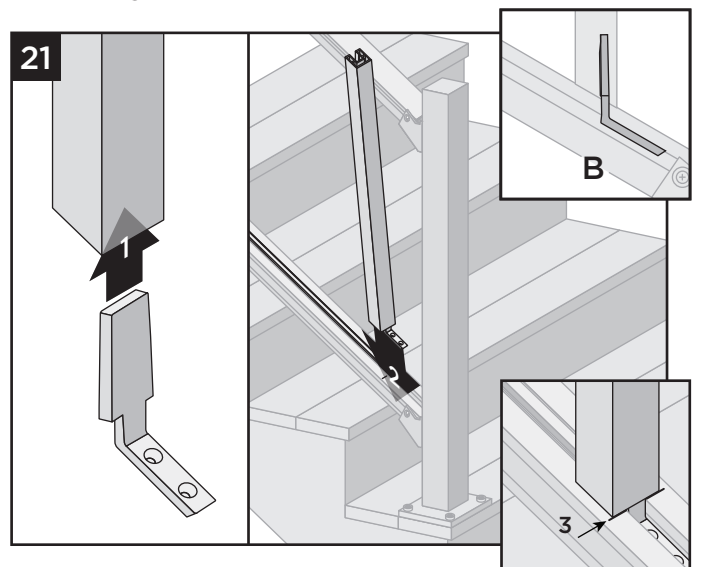

21. At **BOTTOM POST LOCATION**, place L-bracket into vertical and into channel of bottom rail (L-bracket should be oriented in same direction as previous L-bracket.) Ensure that vertical is seated fully flush with bottom rail, bracket is in the channel, and vertical is aligned with mark on rail.

HOW TO INSTALL MESH STAIR RAILING/CONTINUED

TREX SIGNATURE®

22. Mark location for screw attachments in channel of bottom rail. Make sure to mark the placement of the screw holes. **DO NOT** attach L-bracket at this point.

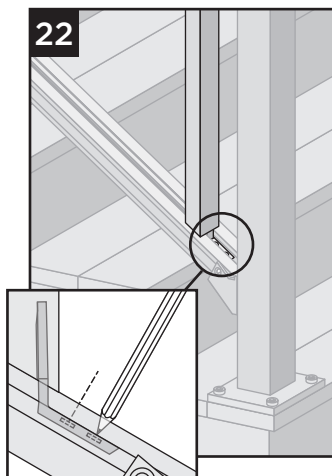

C-TOP Rail BOTTOM POST LOCATION Installing Gaskets and L-Brackets

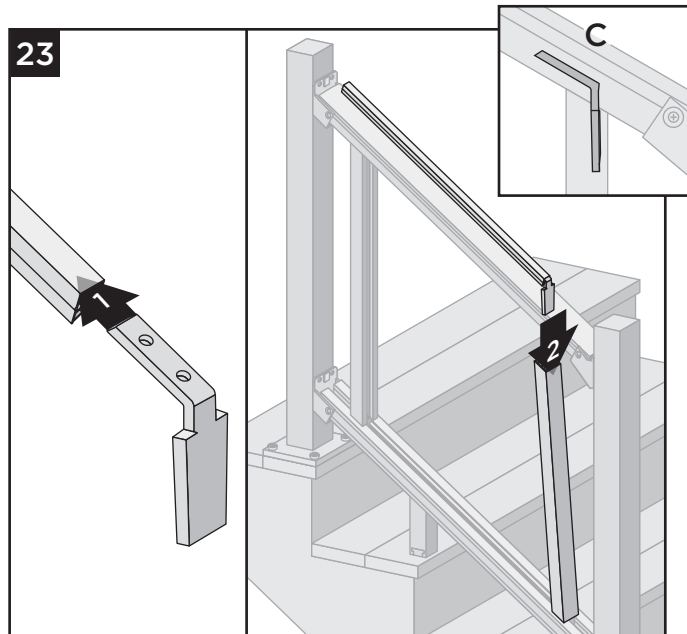

23. At **BOTTOM POST LOCATION**, slide L-bracket into end of gasket. Slide L-bracket (with gasket attached) into top of vertical.

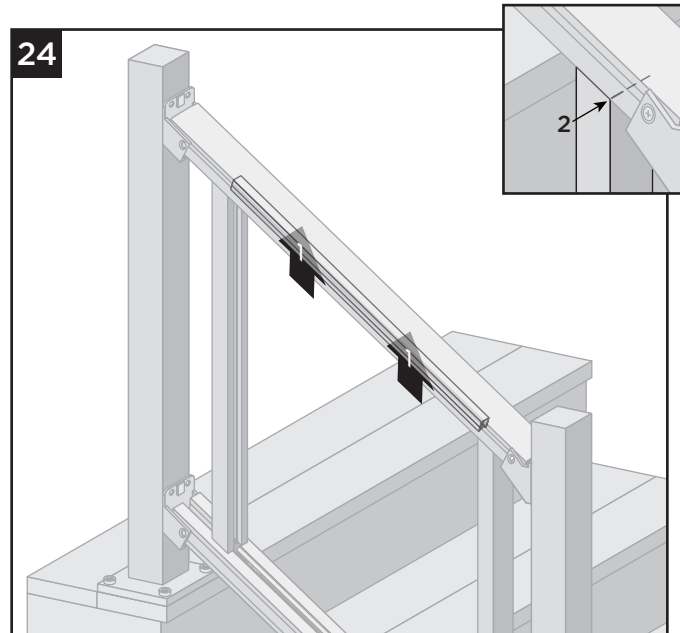

24. Gently tap gasket into channel of top rail. Make sure that vertical is properly aligned with mark on top rail to ensure this is seated in correct location **BEFORE** attaching L-bracket.

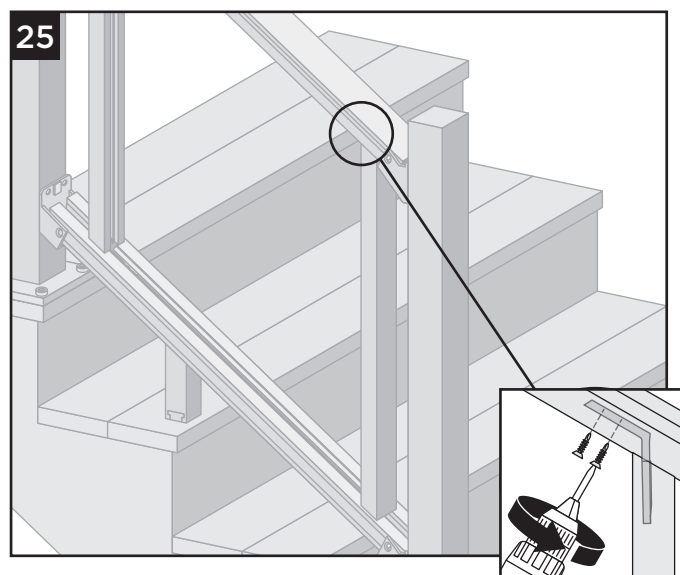

25. Attach L-bracket to top rail using two #8 x 5/8" flat head screws (*provided*).

HOW TO INSTALL MESH STAIR RAILING/CONTINUED

TREX SIGNATURE®

D - Top Rail TOP POST LOCATION Measuring for L-Brackets

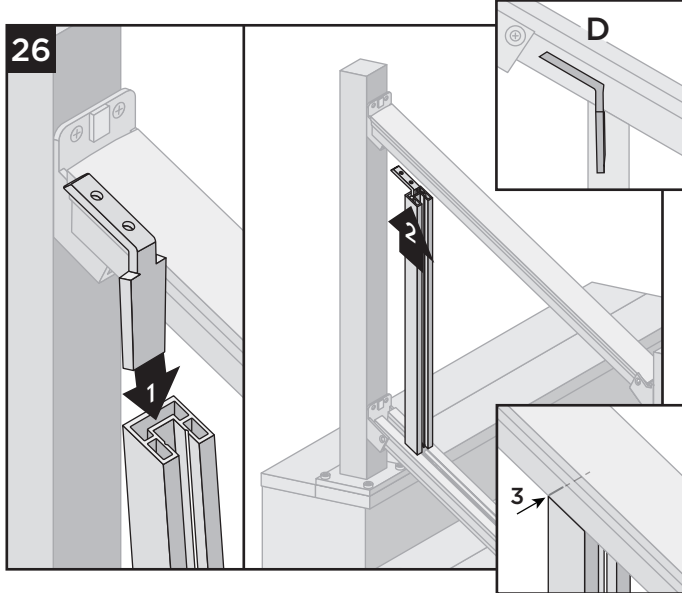

26. Insert L-bracket into vertical and place bracket into channel of top rail. Ensure that vertical is seated fully flush with top rail, bracket is in the channel, and vertical is aligned with mark on rail.

27. Mark location for screw attachments in channel of top rail. Make sure to mark the placement of the screw holes. **DO NOT** attach L-bracket at this point.

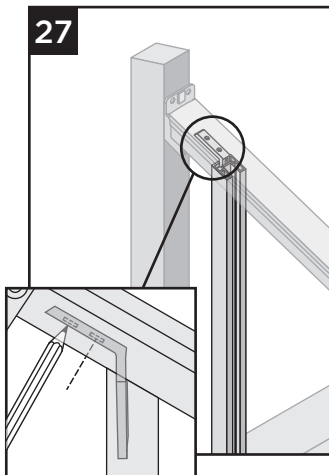

Completing L-Bracket Attachments

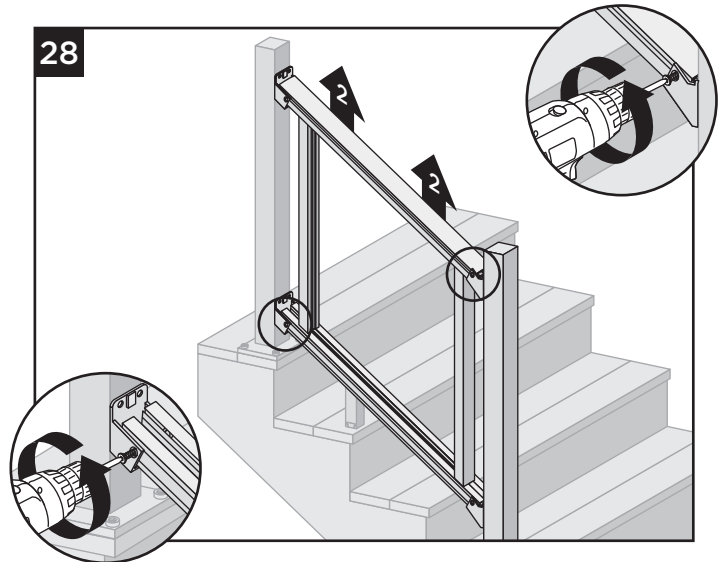

28. Remove the two screws from the brackets that were previously installed in step 9. Remove the railing assembly from the post brackets.

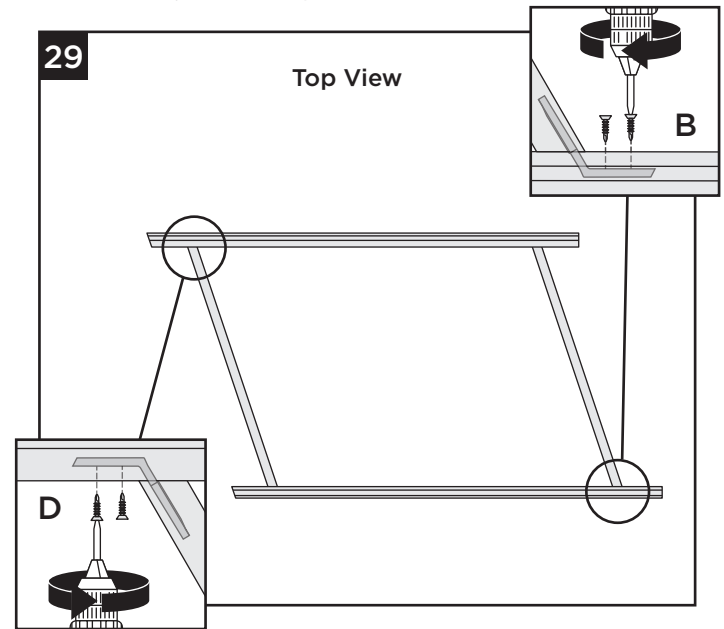

29. Lay railing assembly on large, flat, clean surface. Install remaining L-brackets for section **B** and section **D** into rails where marked using remaining #8 x 5/8" flat head screws (*provided*). Before attachment, verify that verticals align properly with marks.

HOW TO INSTALL MESH STAIR RAILING/CONTINUED

TREX SIGNATURE®

Measuring and Cutting Mesh

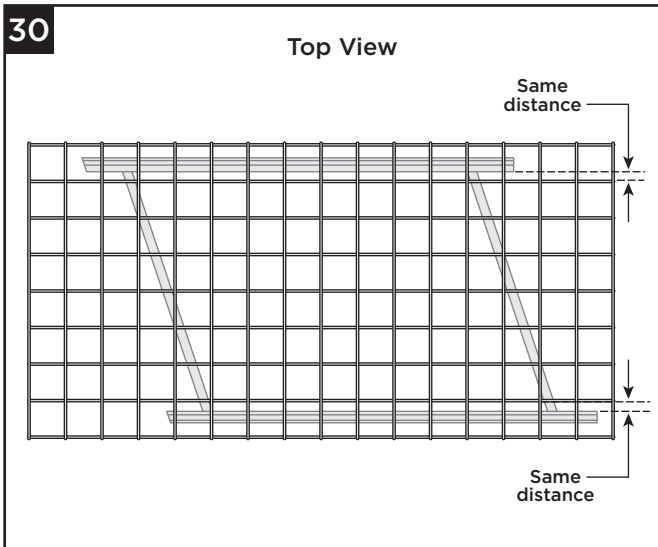

30. Lay mesh panel on top of stair rail assembly and measure so there is equal spacing between mesh panels at both top and bottom rails. Use clamp to hold mesh in place securely once dimensions are set.

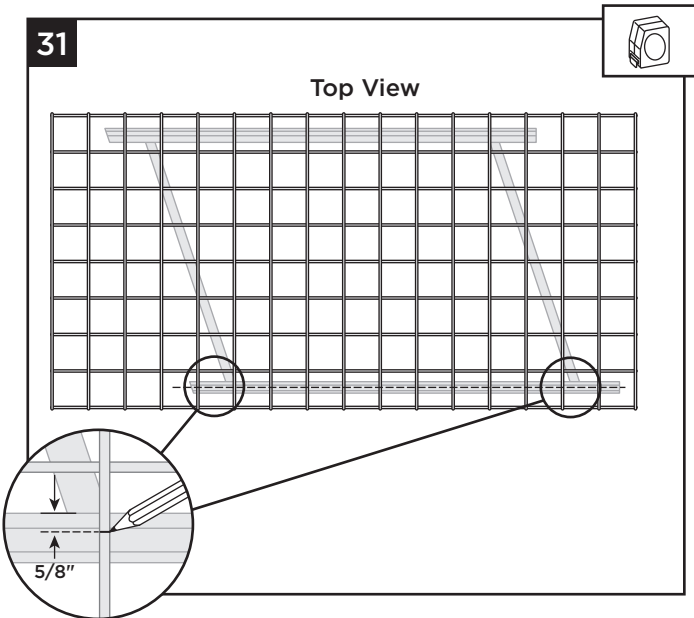

31. At inside of bottom rail, measure **DOWN** 5/8" and mark mesh at this location. Do this at opposite end of mesh panel/bottom rail. Using straight edge, mark **MESH ONLY** at all intersection points.

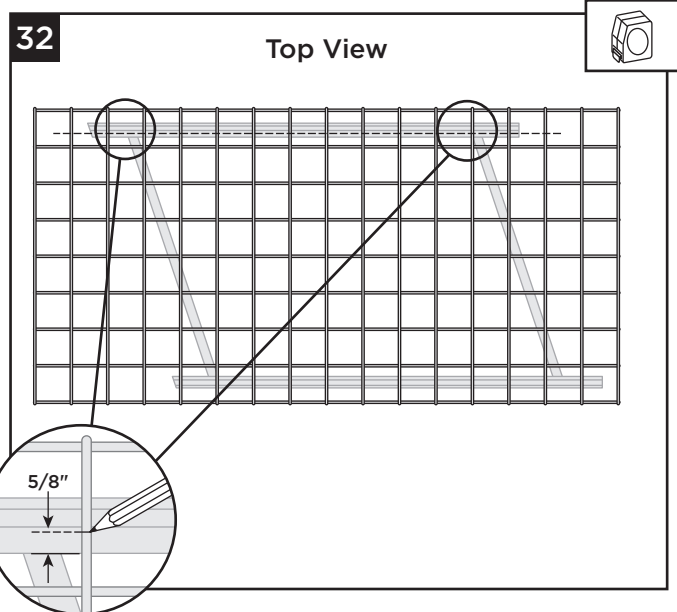

32. At inside of top rail measure **UP** 5/8" and mark mesh at this location. Do this at opposite end of mesh panel/top rail. Using straight edge, mark **MESH ONLY** at all intersection points.

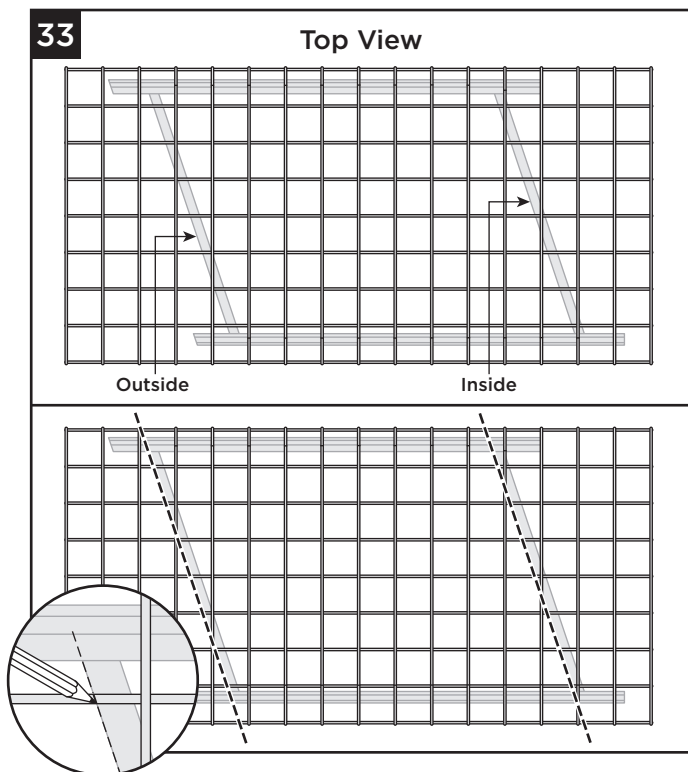

33. For the vertical measurements, align straight edge with **OUTSIDE** of one vertical and mark mesh at all intersection points. Align straight edge with **INSIDE** of opposite vertical and mark mesh at all intersection points.

HOW TO INSTALL MESH STAIR RAILING/CONTINUED

TREX SIGNATURE®

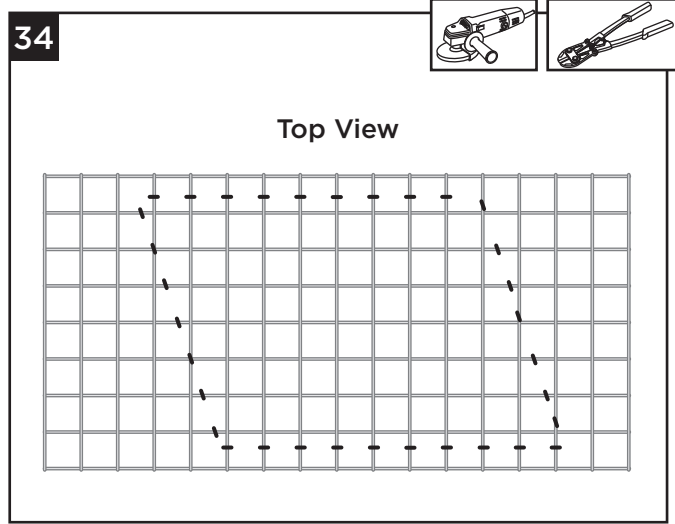

34. Cut mesh at all marks using heavy-duty bolt cutters or angle grinder.

NOTE: USE PROPER SAFETY GEAR IF CUTTING WITH ANGLE GRINDER.

Measuring, Cutting, and Installing Gaskets on Sides of Mesh Panel

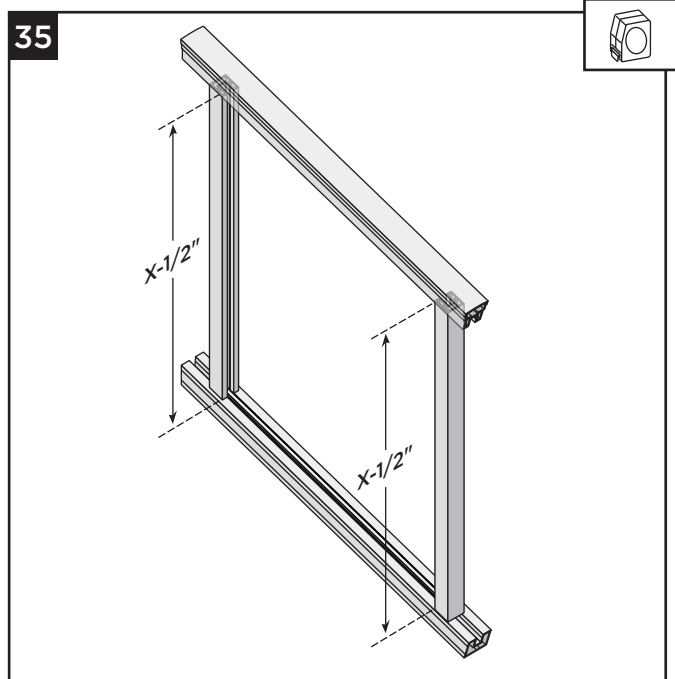

35. Measure distance within the channel of vertical and subtract 1/2".

36. Using cutting pliers, cut both vertical gaskets to length determined above.

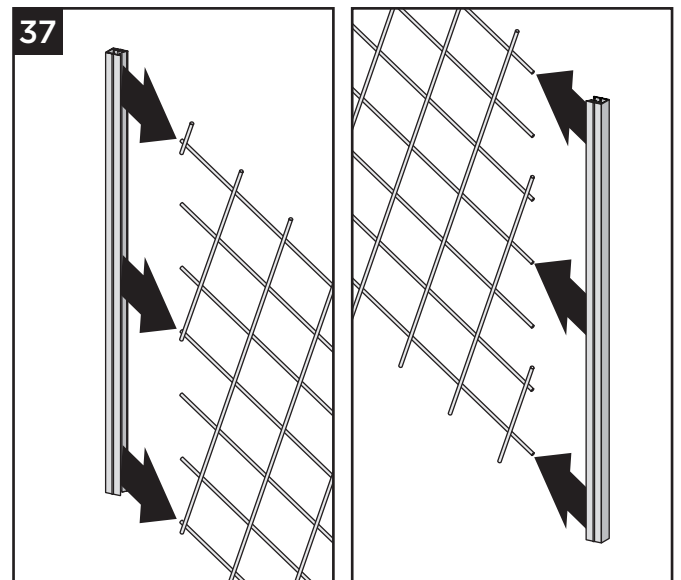
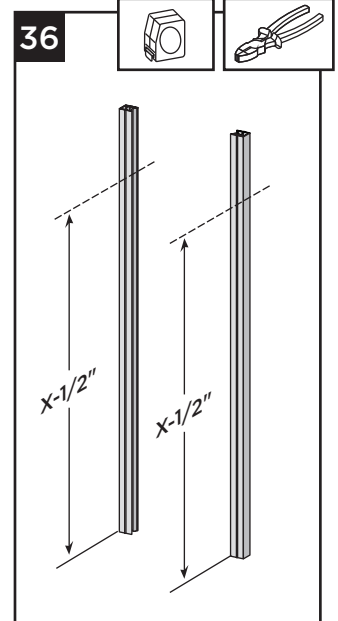

37. Attach vertical gaskets to each side of mesh panel. Make sure gaskets are fully seated onto mesh.



HOW TO INSTALL MESH STAIR RAILING/CONTINUED

TREX SIGNATURE®

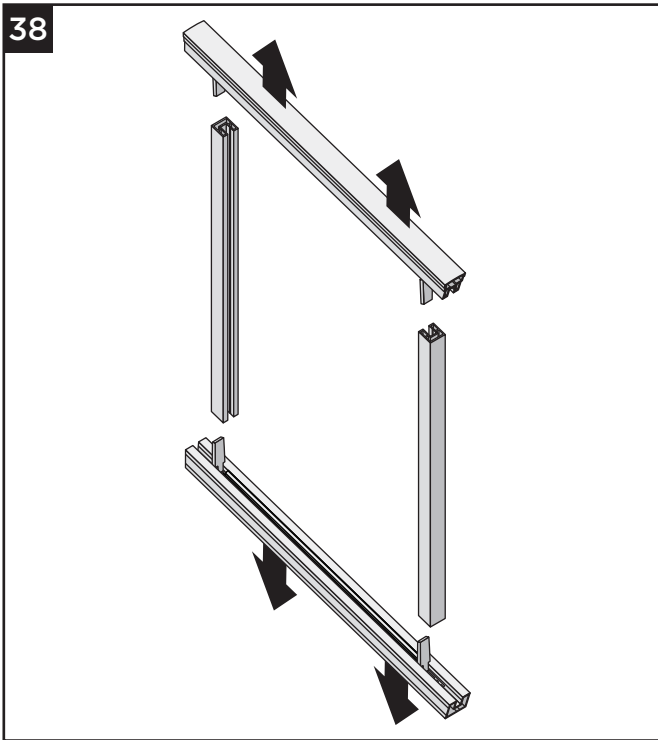

38. Disassemble stair rail panel.

NOTE: No screws have to be removed; verticals will pull off of L-brackets.

Installing Mesh into Verticals and Rails

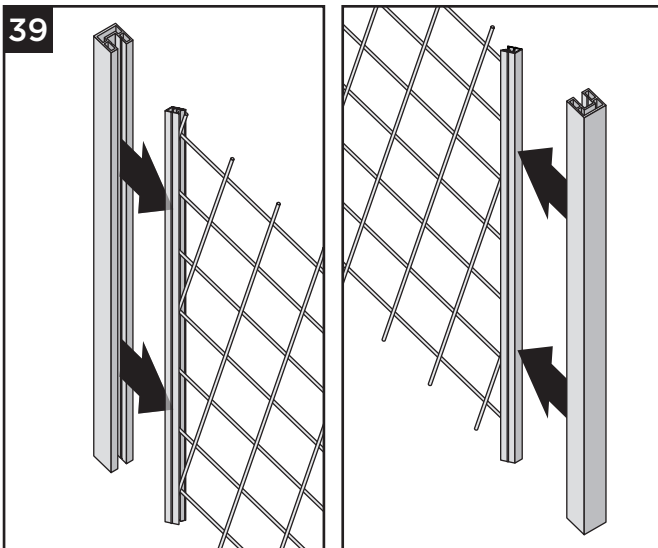

39. Snap verticals onto each side of mesh panel (with vertical gaskets installed). Ensure that verticals are still oriented in correct direction and centered appropriately.

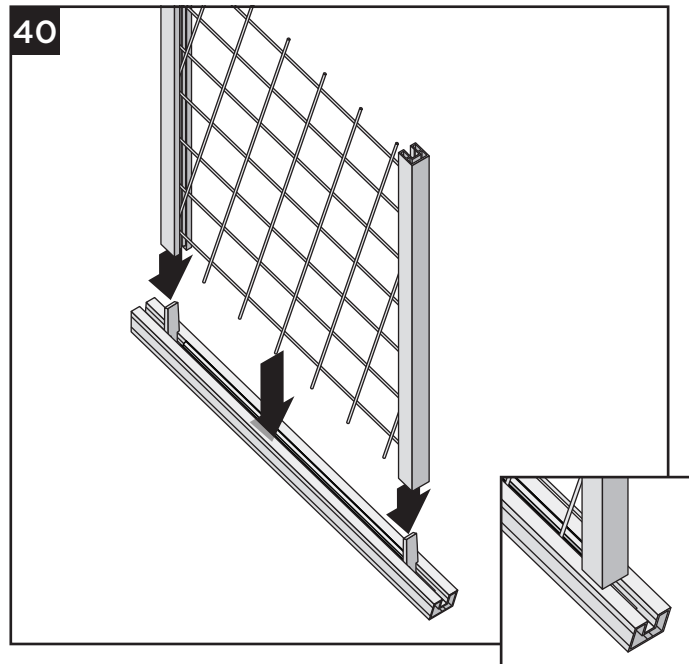

40. Holding verticals, align with L-brackets and press mesh panel into bottom rail gasket in channel. Seat verticals fully onto bottom rail.

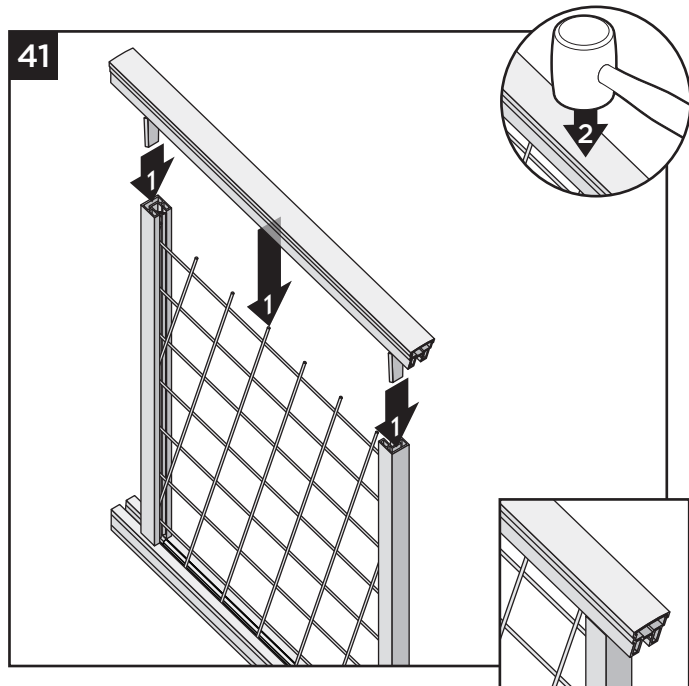

41. Align top rail with L-brackets, and press top rail down so that mesh panel is seated into gasket in channel and top rail is fully seated onto verticals. Use a rubber mallet to gently tap railing into place.

HOW TO INSTALL MESH STAIR RAILING/CONTINUED

TREX SIGNATURE®

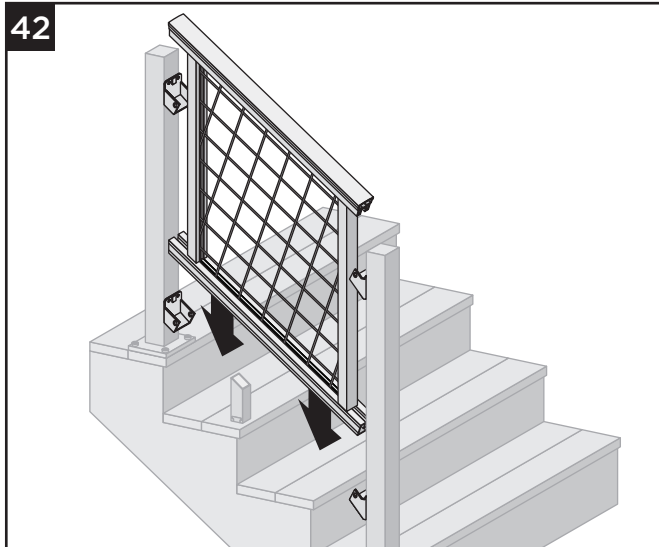

42. Drop assembled stair mesh rail panel into brackets. Ensure that rails are fully seated into brackets and verticals are completely seated on rails.

Installing Snap-in Channel Filler

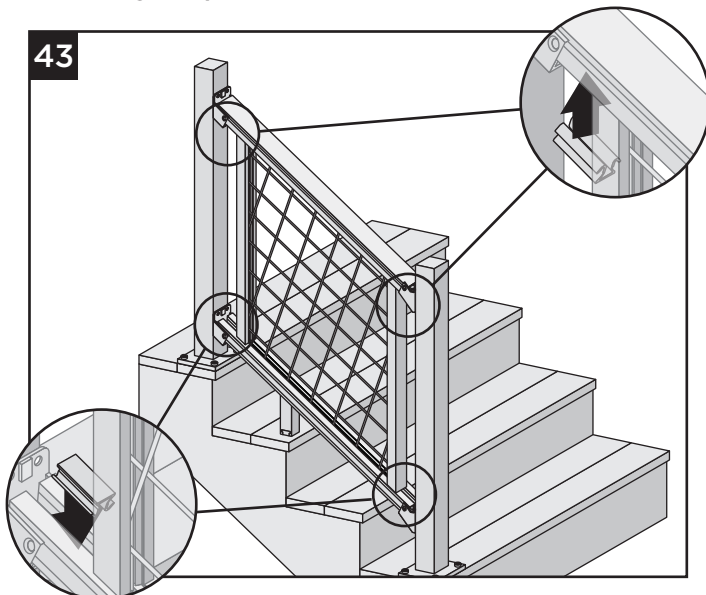

43. Cut snap-in channel filler to correct length and install into channels of bottom and top stair rails. Use of a rubber mallet may assist with this step. **DO NOT** attempt to cut short snap-in pieces with a miter saw. Use an angle grinder or hack saw only.

44. Attach bottom stair rail to bottom stair brackets using two #10 x 1" self-tapping screws (*provided*) on each side of bracket. **YOU MUST PREDRILL ALL EXISTING LOCATIONS FIRST USING 9/64" BIT THAT WAS PROVIDED IN HORIZONTAL MOUNTING KITS.**

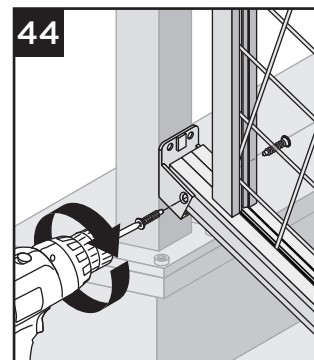

45. Attach top stair rail to top stair brackets using two #10 x 1" self-tapping screws (*provided*) on each side of bracket. **YOU MUST PREDRILL ALL EXISTING LOCATIONS FIRST USING 9/64" BIT THAT WAS PROVIDED IN HORIZONTAL MOUNTING KITS.**

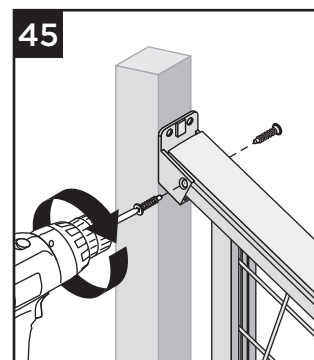

Attachment of Bracket Covers, Skirts, and Caps

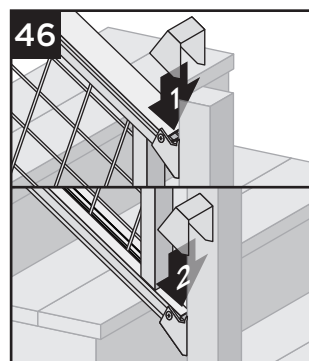

46. Attach corresponding bracket covers over opening in upper and bottom rails.

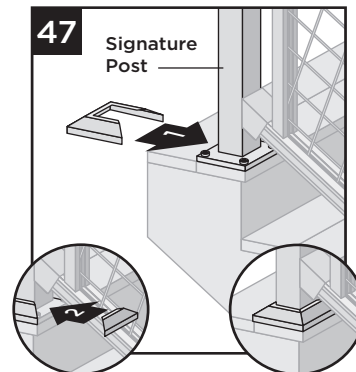

47. Attach provided post skirt to bottom of posts when using Trex Signature posts

HOW TO INSTALL MESH STAIR RAILING/CONTINUED TREX SIGNATURE®

48. Attach post caps to Trex Signature posts. (Use of rubber mallet may be required for secure attachment.)

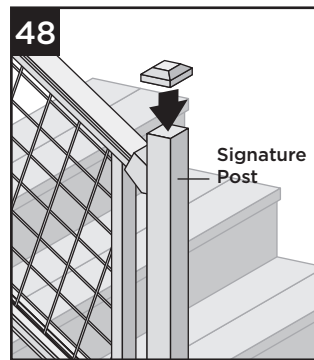

49. Attach post caps to post sleeves using external-grade PVC construction adhesive (apply adhesive on the inside self-centering/corner tabs).

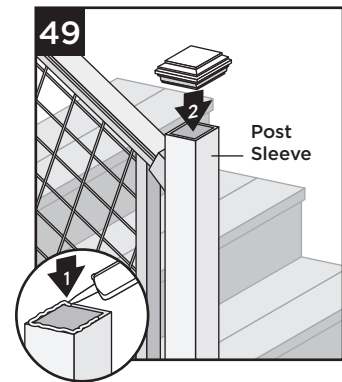

HOW TO INSTALL COCKTAIL MESH STAIR RAILING TREX SIGNATURE®

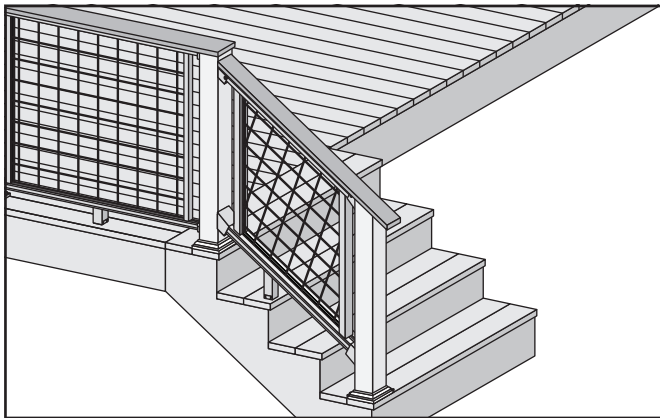

IMPORTANT NOTES:

- » Only for use with pressure-treated 4 x 4 post (3.5" nominal square) and 4" x 4" (102 mm x 102 mm) post sleeve. Trex Signature posts, Trex post mounts or joist mount posts cannot be used with Trex Signature Cocktail Mesh stair railing. Cutting post and post sleeve only applies to the Cocktail style railing.
- » DO NOT CUT LOWER POST/POST SLEEVES UNTIL MESH RAIL STAIR PANEL IS FULLY INSTALLED.
- » THE DECK BOARD USED IN COCKTAIL MESH STAIR WILL NEED TO TERMINATE AT THE UPPER STAIR POST AS SHOWN ABOVE. THE DECK BOARD WILL HAVE TO BE TOENAILED INTO THE SIDE OF THE POST IN THESE AREAS USING 2 APPROPRIATE COMPOSITE DECKING SCREWS - PRE-DRILLING IS RECOMMENDED.
- » Do Not use Enhance for top board.

1. Installing Pressure-treated Posts, Post Sleeves, and Skirts

See instructions on page 176.

2. Installing Brackets

Follow previous stair instructions for the installation of desired brackets, making sure that all dimensions are calculated before installation, and ensuring deck board is placed in correct location.

3. Follow all Stair Mesh instructions for the assembly of the stair mesh panel

Cutting Post and Post Sleeve and Attaching Deck Board to Top Rail

4. Cut post and post sleeves at proper angle so these are flush with the top of the top brackets and/or top rail. BE CAREFUL NOT to CUT brackets.

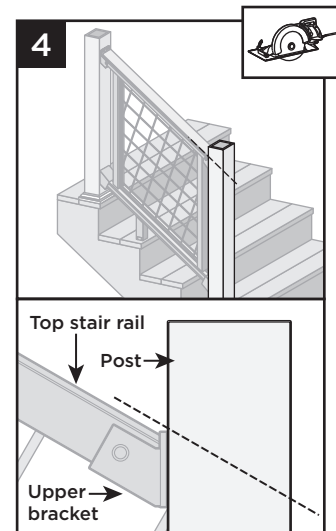

HOW TO INSTALL COCKTAIL MESH STAIR RAILING/CONTINUED TREX SIGNATURE™

5. Place deck boards over top rails. **DO NOT** use Enhance deck boards for top rail. PLACE DECK BOARD ON TOP RAIL TO CHECK FOR PROPER FIT AND RAIL CLEARANCE AT BRACKET LOCATIONS. DECK BOARD MAY REQUIRE EITHER A NOTCH CUT ON THE UNDERSIDE OR SLIGHT PLANING ON THE UNDERSIDE TO ALLOW DECK BOARD TO CLEAR TOPS OF BRACKETS AND SIT FLUSH ON TOP OF POSTS AND RAILS. Attach boards on each post with Trex-recommended composite screws (quantity of 2 per each post/board end).

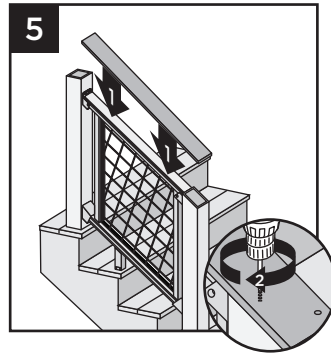

6. Secure boards to top rail using Trex Signature Cocktail Bracket (sold separately). Ensure that there is a bracket at each end of the stair railing section, then space brackets approximately every 24" and attach with 4 screws provided.

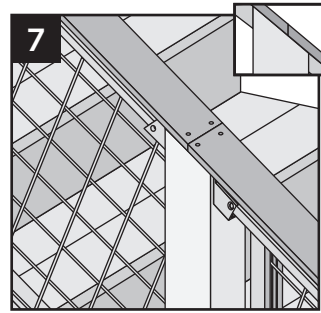
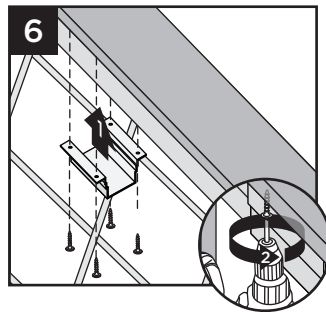

7. Use scarf cut for posts where two deck boards meet.

NOTES:

- » Leave 1/8" (3 mm) gap between deck boards.
- » Deck boards can overhang end of last post maximum 1/2" (13 mm).

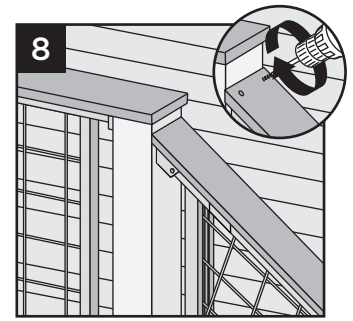

8. Where deck board terminates at upper post, PREDRILL and toenail two approved composite deck screws as shown into post, being careful to avoid hitting stair bracket.

NOTE: Top Bracket Covers are not attached in this configuration.

NOTE: Pre-drilling before attachment is recommended.

HOW TO INSTALL TRADITIONAL MESH STAIR RAILING TREX SIGNATURE™

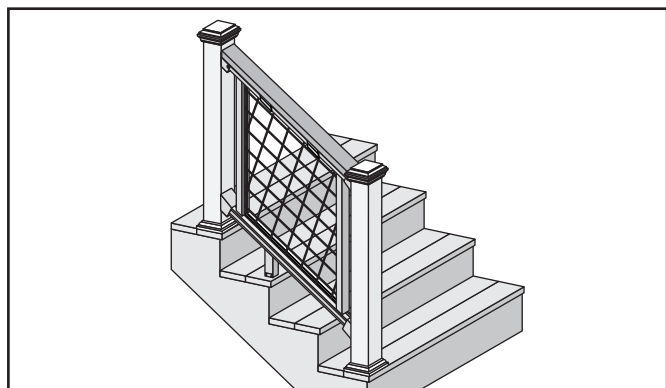

IMPORTANT NOTES:

» *Only for use with pressure-treated 4 x 4 post (3.5" nominal square) and 4" x 4" (102 mm x 102 mm) or 6" x 6" post sleeves, Trex Post Mounts or Trex Joist Mount Post WITH Trex post sleeves. Signature Joist Mount Posts cannot be used with Trex Signature Traditional railing.*

1. Installing Pressure-treated Posts, Post Sleeves, and Skirts

See instructions on page 176.

2. Installing Brackets

Follow previous stair instructions for the installation of desired brackets, making sure that all dimensions are calculated before installation, and ensuring deck board is placed in correct location.

3. Follow all Stair Mesh instructions for the assembly of the stair mesh panel.

Attaching 2 x 4 to Top Rail

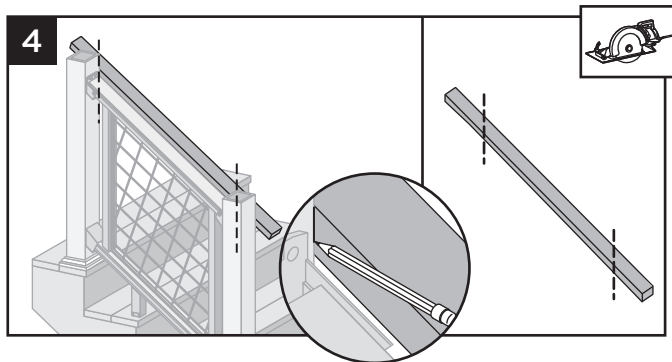

4. Place 2 x 4 beside top rail. Mark and cut (both ends need to be cut on an angle for proper fit).

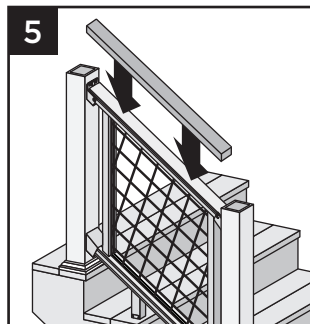

5. Place 2 x 4 on top stair rail.

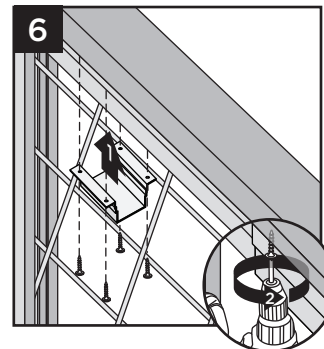

6. Secure 2 x 4 to top rail using Trex Signature Cocktail Bracket (sold separately). Ensure that there is a bracket at each end of the railing section, then space brackets approximately every 24" and attach with 4 screws provided.

NOTE: *Pre-drilling before attachment is recommended.*

7. Pre-drill a pilot hole and toenail 2-1/2" (6.4 cm) screw at each end of 2 x 4 into post on back side of rail (side not facing decking).

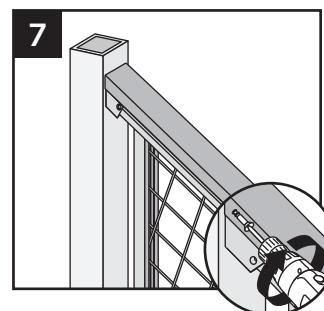

NOTE: *Top Bracket Covers are not attached in this configuration.*

HOW TO INSTALL ALUMINUM GATE

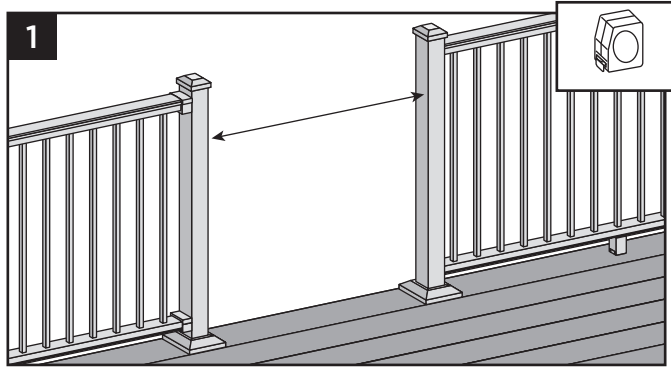

1. Measure opening between posts (gates can be customized to fit nearly any opening up to 48" [1219 mm] wide).
2. Subtract 1-7/8" (48 mm) from above measurement. This will allow for proper gapping and location of gate.

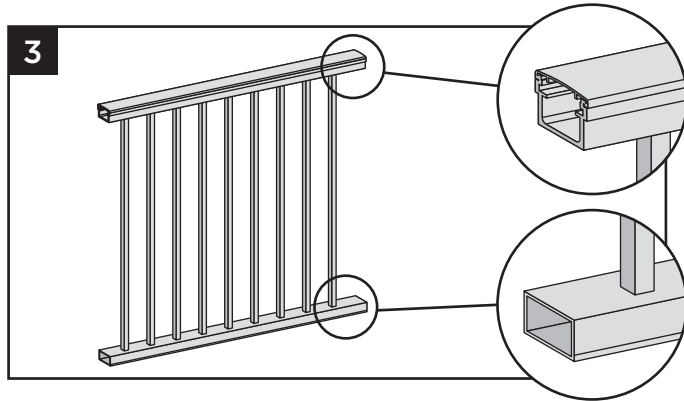

3. Identify top and bottom of panel.

NOTE: The posts only fit in one direction.

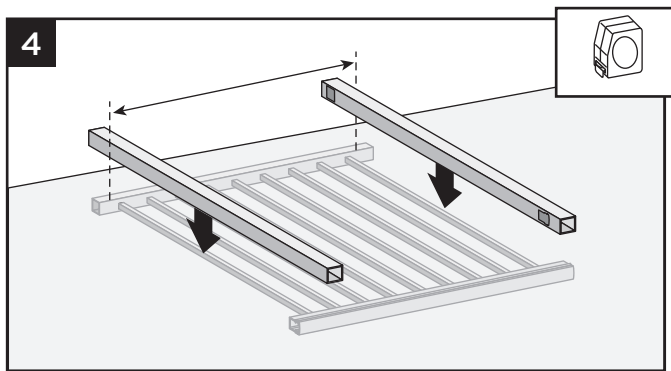

4. Lay panel on a flat non-marring surface. Place posts on top of panel. Place posts so that width measurement from Step 2 is to the outside of each post.

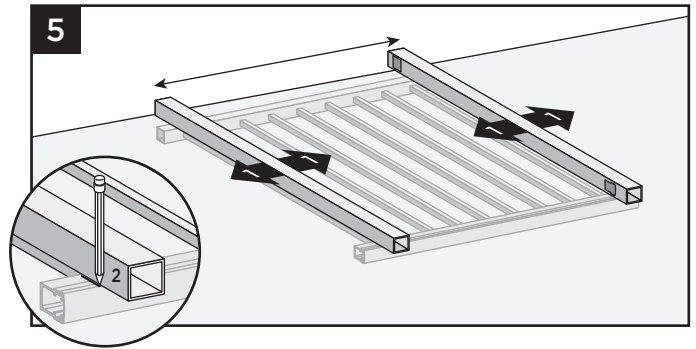

5. Adjust posts so that cut marks do not fall on a baluster. Make sure distance from first baluster to post is the same on both sides. Mark cut locations on panel.

NOTE: If widths do fall on a baluster, cut baluster flush at top and bottom prior to cutting panel.

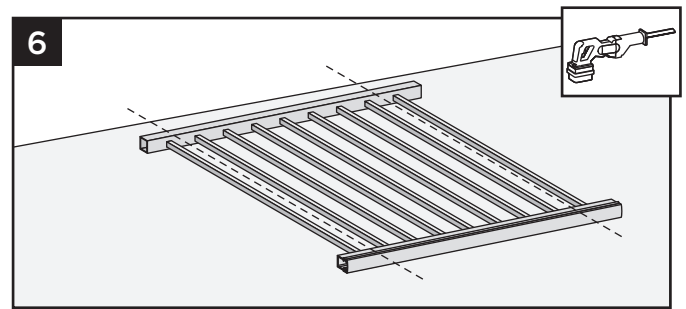

6. Cut panel using a reciprocating saw (equipped with a metal blade).

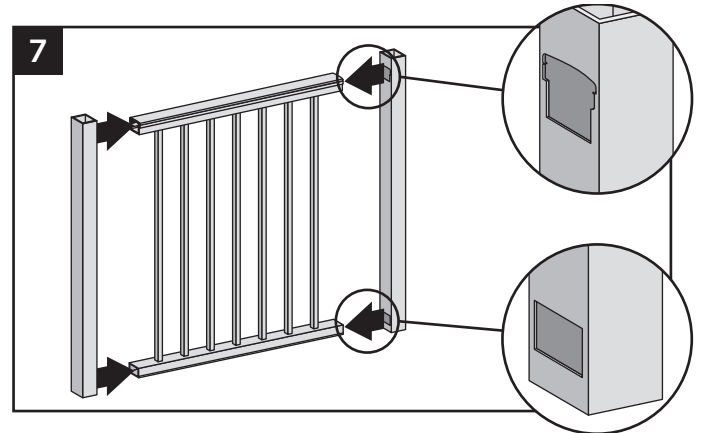

7. Insert posts into panel.

NOTE: Make sure top and bottom of panel orientation is correct.



HOW TO INSTALL ALUMINUM GATE/CONTINUED

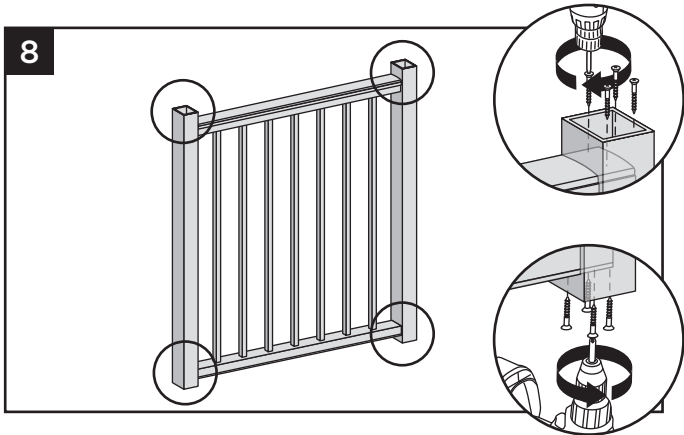

8. Secure posts to panel with four #8-18 short self-tapping screws (*provided*) in each location.

9. Attach shorter side of hinge to the gate.

NOTE: Refer to instructions included in hardware package. Be sure to use correct fasteners for aluminum. See chart below.

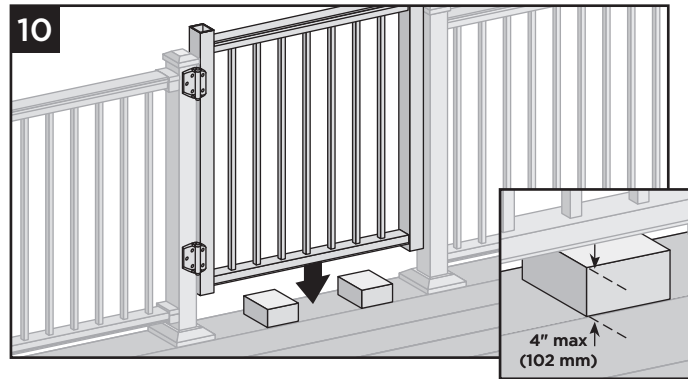
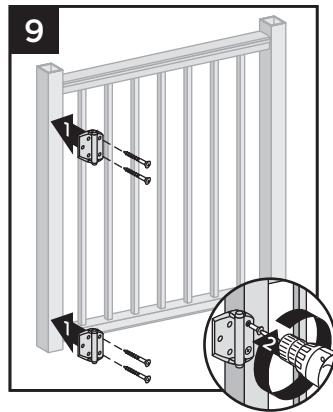

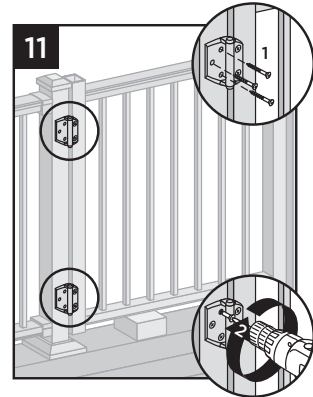

10. Place gate in opening on blocks. Sweep between bottom of gate and top of deck cannot exceed 4" (102 mm) per IRC/IBC code regulations. Ensure bottom gate posts will be high enough to clear skirts on bottom of deck posts.

11. Make sure posts are plumb and gate is level. Attach longer side of hinges to post using appropriate hardware for type of post installed. Install hinge cover.



NOTES:

- » Both wood and aluminum screws are included in hardware kit. (Refer to chart under Step 9.)
- » If using Trex Post Mounts with Post Sleeves, pre-drilling is required using 1/8" (3 mm) drill bit, as you must go through both aluminum sleeve and internal post.

MINIMUM FASTENER SIZE		
SCREWS		
Type	Length	No.
 Wood Screw	2-1/2" (64 mm)	#9
 Metal Screw	2" (51 mm)	#8-18

NOTE: Use of non-Trex hardware is not recommended and could result in serious injury or death.

12. After determining location and height of hinge and hasp (If using PT post/post sleeve, measure location of latch body before attachment to post sleeve. If necessary the L bracket of the latch body can be removed in order to place the latch body in proper location for latch bolt to engage.), install per instructions included with hardware kit.

13. Ensure proper operation of gate. Hinge tension is adjustable (*check hardware kit instructions for more detail*).

14. After gate installation, place blocks under gate for support. Use a rubber mallet to install cap onto gate post. Repeat for other gate post cap. Snap all hinge covers into place.

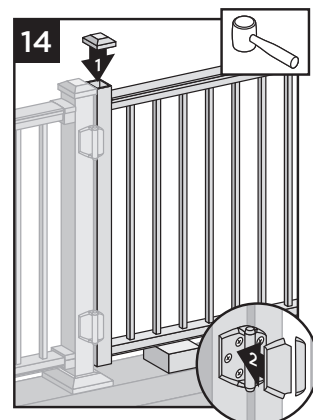

TREX SELECT® HORIZONTAL RAILING

NOTES:

- » TREX SELECT RAILINGS ARE DESIGNED TO BE INSTALLED OVER THE DECKING FRAME OR ON INSIDE OF RIM JOIST. NOTCHING OF PRESSURE-TREATED POSTS OR POSTS INSTALLED ON OUTSIDE OF RIM JOIST IS NOT ALLOWED.
- » All Trex Select Railing lengths are manufactured at ON CENTER dimensions (spanning from center of each post): 67-5/8" (176.8 cm) for 6' (1.83 m) on center, and 91-5/8" (235.3 cm) for 8' (2.44 m) on center. Note that railings are designed to be slightly longer than required to allow for very slight play in post placement - trimming may be required. IT IS VERY IMPORTANT TO MEASURE FIRST.

Care and Cleaning

Maintaining the appearance of your Trex Select railing is important. Occasional washing is recommended. Over time your railing may show signs of weathering as a result of exposure to the elements. The frequency of cleaning will depend on the environment and exposure to various types of elements.

- » Clean railing with standard cleaning vinegar or mild soap and water.
- » For more detailed cleaning recommendations, please refer to the Trex Railing Care and Cleaning guide found on www.trex.com.

PARTS

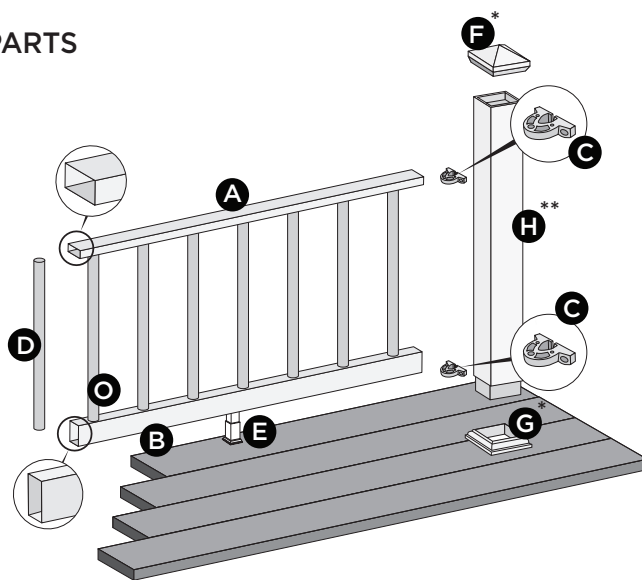

DETERMINING BALUSTERS NEEDED

Baluster Type	Per 6' OC Section	Per 8' OC Section
Round Aluminum Baluster (Horizontal Application)	14	20

CODE APPROVED APPLICATIONS

	6' Railing	8' Railing
< 30" height decking	Acceptable (Code approval not applicable)	Acceptable (Code approval not applicable)
IRC Compliant	Yes	Yes*
IBC Compliant	No	No

*TREX SELECT 8' ALUMINUM RAIL STIFFENER (sku SELALRAILSTIFFENER) MUST ALSO BE USED. Sold separately.

- A. Select top rail
- B. Select bottom rail
- C. Brackets
- D. Balusters
- E. Adjustable foot block
- F. Post sleeve cap*
- G. Post sleeve skirt*
- H. Post sleeve - 4" x 4" (102 mm x 102 mm) or 6" x 6" (152 mm x 152 mm) post sleeve)**

* Item not included in the Select railing kits.

** Both 4" x 4" (102 mm x 102 mm) and 6" x 6" (152 mm x 152 mm) post sleeves are designed to fit over 4x4 pressure-treated post.

NOTES:

- » If installing 42" (1067 mm) railing, use longer post sleeves and measure accordingly to ensure a proper cut. DO NOT CUT TO ACTUAL 42" LENGTH WITHOUT CONFIRMING WHAT STYLE OF RAILING YOU ARE INSTALLING.
- » If using 8' railings, the Trex Select 8' Aluminum Rail Stiffener (sku SELALRAILSTIFFENER) can also be used to allow for the rail to be stronger if required.
- » Ensure pressure-treated posts are installed at proper heights so when post sleeves are installed, both the PT post and post sleeve are flush at top.
- » See specific installation instructions for attachment of Trex post mounts or Trex Joist Mount Posts prior to installing any railing.

Screws Supplied with RSB

C1. Wood screw for attachment of RSB to wood post/composite sleeve

C2. Self-drilling screw for attachment of RSB to rail

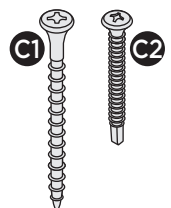

TREX SELECT® HORIZONTAL RAILING

RAILING CONFIGURATIONS

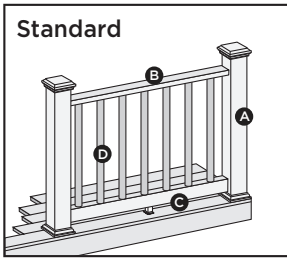

- Cutting post sleeves is **NOT** required.
- A. Pressure-treated post or Trex post mounts with Trex Transcend post sleeves, or Trex joist mount posts
 - B. Select top rail
 - C. Select bottom rail
 - D. Select balusters
- See page 194 for "How to Install Standard Railing".

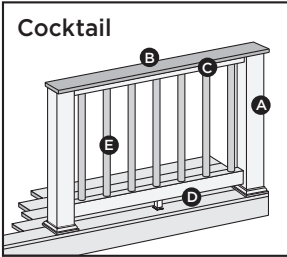

- Post sleeves **WILL NEED TO BE CUT.**
- A. Pressure-treated post with Trex Transcend post sleeve
- NOTE:** » Only for use with 4" x 4" (102 mm x 102 mm) post sleeve.
 » Trex post mounts or joist mount posts cannot be Select cocktail design.
- B. Deck board top rail.
- NOTES:** » Enhance cannot be used
 » Deck boards will need to be cut to fit each rail span
- C. Select top rail
 - D. Select bottom rail
 - E. Select balusters
- See page 196 for "How to Install Select Cocktail Railing".

POST SLEEVES WILL NEED TO BE CUT

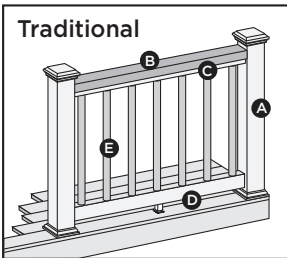

- Cutting post sleeves is **NOT** required.
- A. Pressure-treated post or Trex post mounts with Trex Transcend post sleeves, or Trex joist mount posts
 - B. 2 x 4 lateral top rail
 - C. Select top rail
 - D. Select bottom rail
 - E. Select balusters
- See page 198 for "How to Install Traditional Railing".

HOW TO INSTALL STANDARD HORIZONTAL RAILING TREX SELECT®

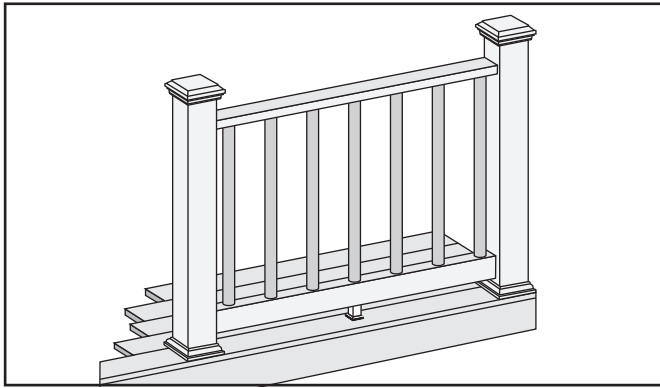

Read all instructions **BEFORE** installation.

Important: Post sleeves are **NOT** to be cut for this design style.

Installing Pressure-Treated Posts

» PLEASE REFER TO LOCAL BUILDING CODE REQUIREMENTS PRIOR TO ATTACHING PRESSURE TREATED POSTS. BELOW INSTRUCTIONS ARE GUIDELINES FOR GENERAL REQUIREMENTS.

- » Select Railing Kits are designed for posts to be installed at maximum of 6' or 8' (1.83 m or 2.44 m) ON CENTER depending on the length being used. **NOTE:** Smaller spans are allowed.
- » Attach posts using 1/2" (13 mm) carriage bolts.
- » Minimum joist size is 2" x 8" (51 mm x 203 mm).
- » Top bolts must be 1" (25 mm) from tops of joists.
- » Bottom bolts must be 5-1/8" (130 mm) from top bolts.

NOTE: Blocking **MUST** be added for extra strength.

Installing Post Sleeve Skirts and Post Sleeves

2. Slide post sleeve skirt over post and down to rest on decking surface. Slide post sleeve over post and position inside post sleeve skirt.

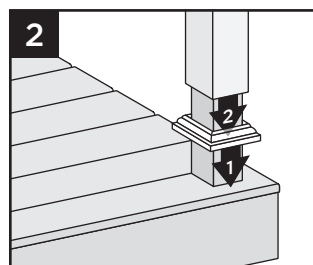
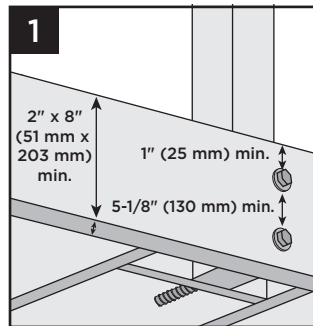

NOTE: Shims can be used to plumb post sleeves.

Cutting Railings

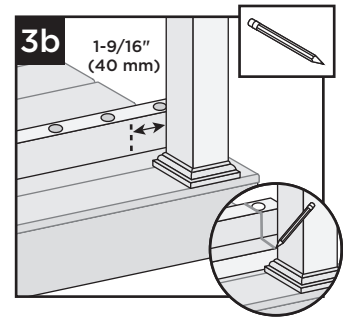
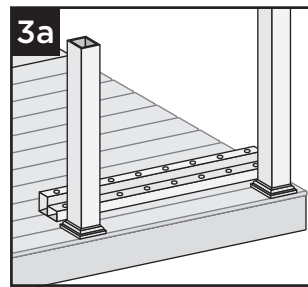

3a. Position bottom and top rails between posts, ensuring baluster holes are lined up and spaced evenly.

3b. Also allow for a minimum of 1-9/16" (40 mm) on each end of rail for bracket placement AND baluster clearance. Mark rails at intersection of rail and post.

IMPORTANT NOTE REGARDING FOOT BLOCK INSTALLATION:

- » Refer to detailed instructions (Trex Select rail instructions) included with foot block prior to installation of railing section as these include other required steps for proper installation.

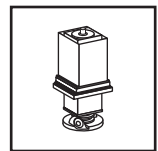

Attaching Foot Block to Bottom Rail

4. Invert the bottom rail. Center and drill a hole using a 3/16" (5 mm) drill bit. This will be location for foot block attachment (to be installed last).

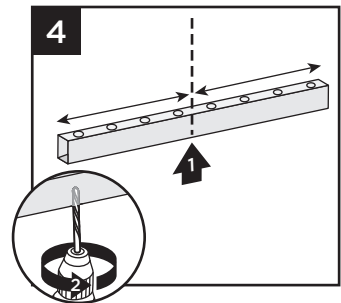

Attaching Brackets to Rails

- 5a. Position brackets on each end of TOP RAIL on the same side as baluster holes. Attach brackets using three #8-18 x 1" self-drilling screws (provided).

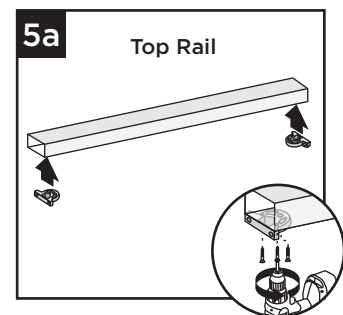

HOW TO INSTALL STANDARD HORIZONTAL RAILING TREX SELECT®

5b. Position brackets on each end of BOTTOM RAIL on the **OPPOSITE SIDE** of the baluster holes. Attach brackets using three #8-18 x 1" self-drilling screws (*provided*).

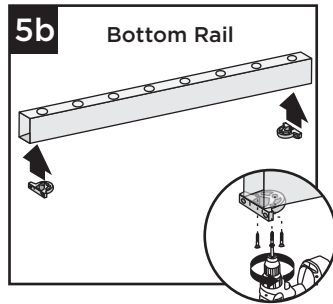

NOTE: For ease of bracket attachment place rail against stationary flat vertical surface along with bracket.

Assembling Railing Section

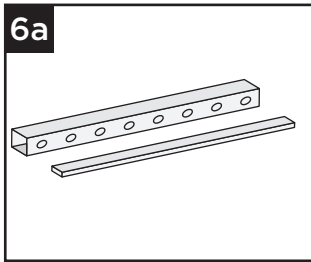

6a. On a clean flat surface, lay bottom railing on its side. Make sure to allow enough room for installation of balusters and top rail. Place a scrap piece of 1" (25 mm) decking board running parallel to bottom rail for support when installing balusters.

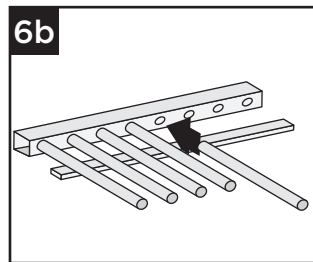

6b. Insert balusters into bottom rail slots until balusters are fully seated.

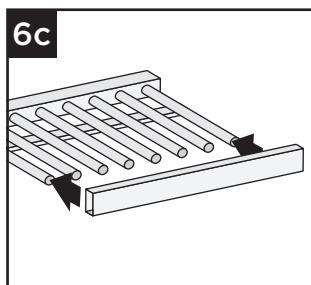

6c. Attach top rail to balusters, feeding each baluster into required slots. Start on one end and work towards the other.

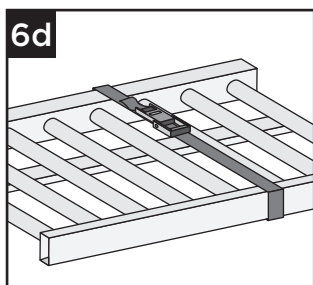

6d. To help temporarily secure the railing section together, place a ratchet strap around the top and bottom rail and tighten until snug. **DO NOT OVERTIGHTEN AS YOU CAN BEND THE RAILING.**

Installing Railing Section to Posts

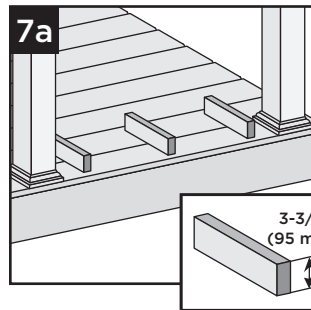

7a. Using scrap material (i.e. 2 x 4s, decking boards, etc.) cut at least three support blocks at 3-3/4" (95 mm) in height. Place one each on decking surface beside each post and one near center of span.

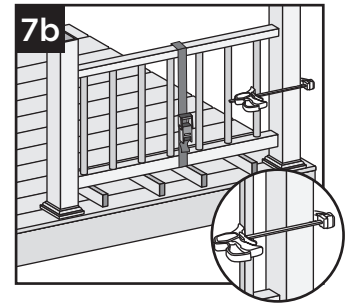

7b. Lift secured railing section up, and **CENTER** this section in between the spanned posts on pre-positioned support blocks.

NOTE: To help stabilize railing section use a quick-grip clamp (or other type of clamp) and clamp the first baluster to post sleeve. **DO NOT OVERTIGHTEN CLAMP.**

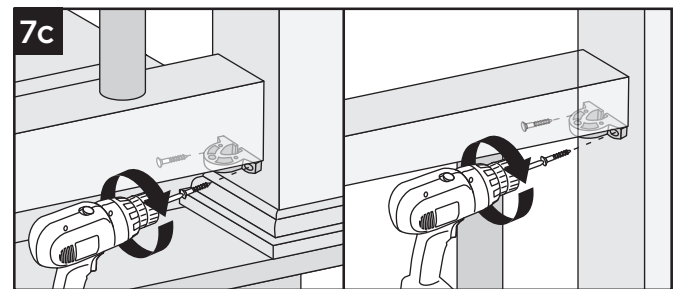

7c. Install both bottom and top brackets on each side to post using two #8-10 x 2" wood screws (*provided*).

IMPORTANT NOTE: SET DRILL TO LOW SPEED AND LOW CLUTCH SETTING WHEN INSTALLING THESE SCREWS. **DO NOT USE IMPACT DRIVER.**

Attaching Post Caps and Installing Foot Block

8. Secure post caps with silicone or PVC adhesive (apply adhesive on the inside self-centering/corner tabs). Attach foot block per foot block instructions.

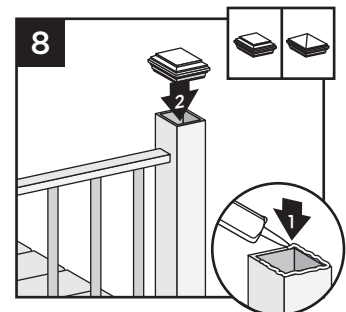

NOTE: Clean up any excess adhesive before it dries.

HOW TO INSTALL COCKTAIL HORIZONTAL RAILING TREX SELECT®

Important: ONLY use for use with pressure-treated 4x4 post (3.5" nominal square) and 4" x 4" (102 mm x 102 mm) post sleeve. Trex Post Mounts or Joist Mount Posts cannot be used with Select Cocktail railing.

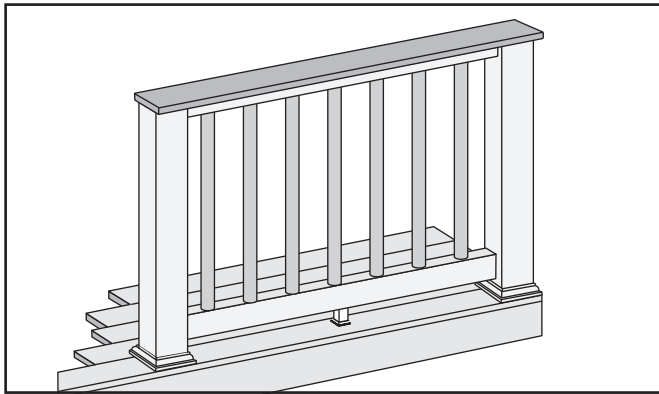

1. Installing Pressure-Treated Posts, Post Sleeve Skirts and Post Sleeves

See instructions on page 194.

Cutting Post and Post Sleeve

2. Mark and cut post and post sleeve measuring from deck surface:
 - » 36-1/8" (918 mm) for 36" (914 mm) height.
 - » 42-1/8" (1070 mm) for 42" (1067 mm) height.

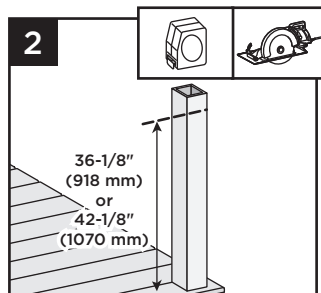

3. Cutting Railings

See instructions on page 194.

4. Attaching Foot Block to Bottom Railing

See instructions on page 194.

NOTES:

- » Leave 1/8" (3 mm) gap between deck boards.
- » Deck boards can overhang end of last post maximum 1/2" (13 mm).

Cutting Deck Board

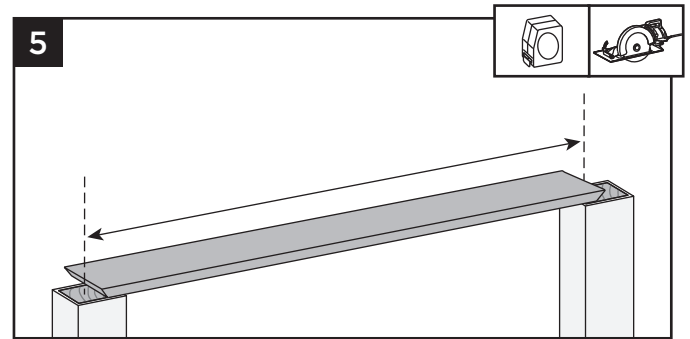

5. Cut deck boards to appropriate length of railing span, remembering to include extra space on each side of the deck board to allow for attachment to the post. Decking boards must cover 1/2 of the pressure-treated post to allow this to be fastened later.

6. Place inverted deck board (top side of deck board face down) on clean, flat surface. (**DO NOT** use Enhance deck boards for top rail).

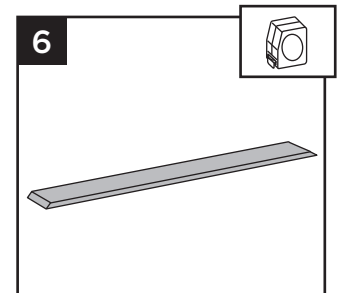

Attaching Deck Board to Select Top Rail

7. Place inverted Select top rail (orient properly so baluster holes are shown top side up), on the deck board, centered in both directions to allow final attachment to post.

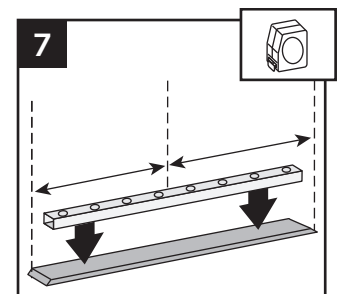

HOW TO INSTALL COCKTAIL HORIZONTAL RAILING/CONTINUED TREX SELECT®

8. Secure deck board to Select top rail with 3/4" screws provided approx. every 16" on center. Screws are to be installed inside of the baluster holes into the decking board. **DO NOT** overtighten.

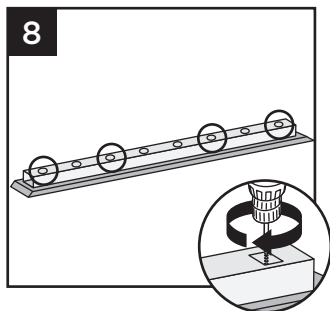

NOTES:

- » A long drill bit will be required to fit inside the baluster holes.
- » If installing 8' rail section and using Aluminum Rail Stiffener, predrilling will be required through the stiffener.

9. **Attaching Brackets to Rails**
See instructions on page 194.

10. **Assembling Railing Sections**
See instructions on page 195.

11. **Installing Railing Sections to Posts**
See instructions on page 195.

12. **Attaching Deck Board to Posts**
Attach boards on each post with Trex recommended composite screws (quantity of 2 per each board end).

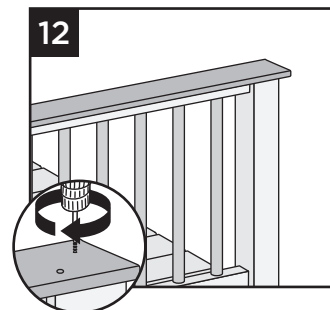

13. **Installing Foot Block**
Install foot block per detailed instructions.

HOW TO INSTALL TRADITIONAL HORIZONTAL RAILING TREX SELECT®

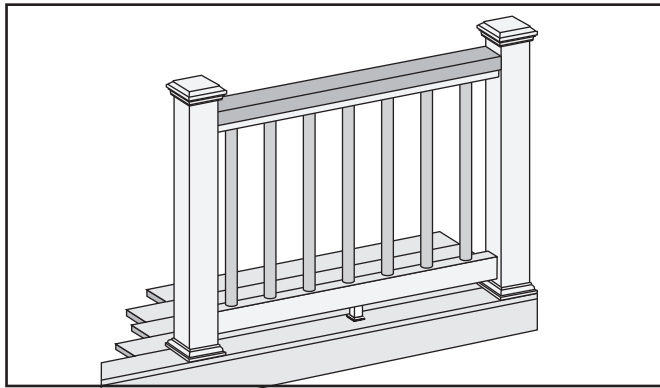

1. Installing Pressure-Treated Posts, Post Sleeve Skirts and Post Sleeves

See instructions on page 194.

2. Attaching Foot Block to Bottom Railing

See instructions on page 194.

3. Cutting Railings

See instructions on page 194.

Cutting 2 x 4

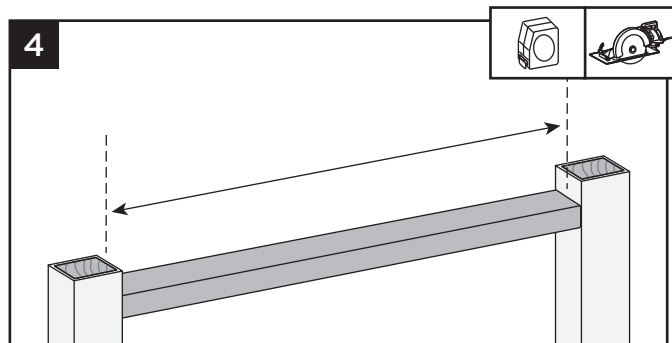

4. Cut 2 x 4 to same length of the inverted Select top rail.

Attaching 2 x 4 to Select Top Rail

5. Place inverted 2 x 4 (top side face down) on clean, flat surface.

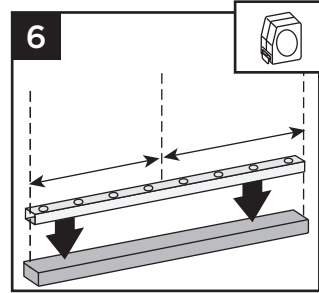
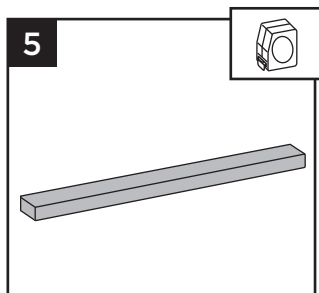

6. Place inverted Select top (orient properly so baluster holes are shown top side up) on 2 x 4.
7. Secure 2 x 4 to Select top rail with 3/4" screw provided approximately every 16" on center. Screws are to be installed inside of the baluster holes into the decking board.

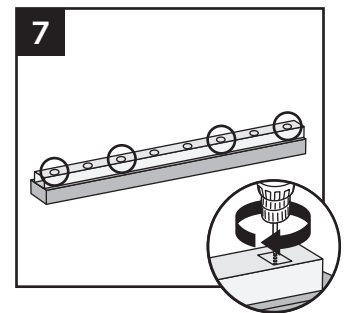

NOTES:

- » **DO NOT** overtighten. Note that a long drill bit will be required to fit inside the baluster holes.
- » If installing 8' rail section and using Aluminum Rail Stiffener, predrilling will be required through the stiffener.

8. Attaching Brackets to Rails

See instructions on page 194.

9. Assembling Railing Sections

See instructions on page 195.

10. Installing Railing Sections to Posts

See instructions on page 195.

11. Attaching 2x4 to Posts

Pre-drill a pilot hole and toenail 2-1/2" (64 mm) screw at each end of 2 x 4 into post on back side of rail (side not facing decking).

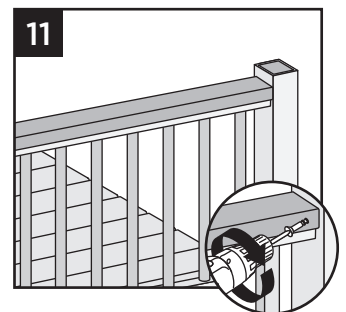

12. Attaching Post Caps and Installing Foot Block

Secure post caps with silicone or PVC adhesive (apply adhesive on the inside self-centering/corner tabs). Attach foot block per foot block instructions.

HOW TO INSTALL ON-AN-ANGLE RAILING TREX SELECT®

NOTE: Brackets are designed to be installed up to a 45° angle.

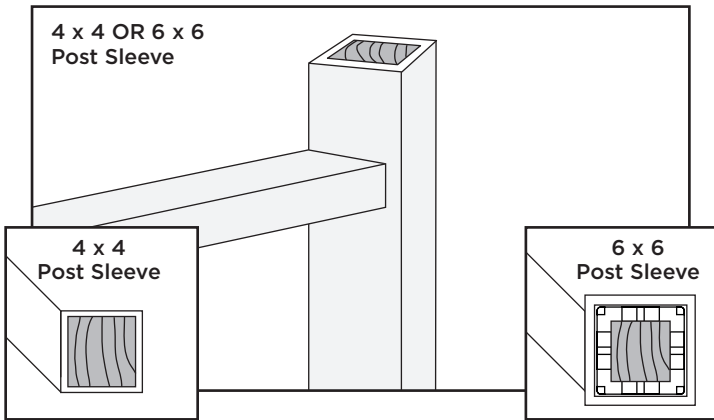

Both 4" x 4" (102 mm x 102 mm) or 6" x 6" (152 mm x 152 mm) post sleeves work well for angles up to 45 degrees. Bottom rail brackets may need to be slightly offset to one side in order to fit properly to hold rail in place. Before attaching bracket to rail, measure and mark to ensure bottom rail remains parallel to upper rail.

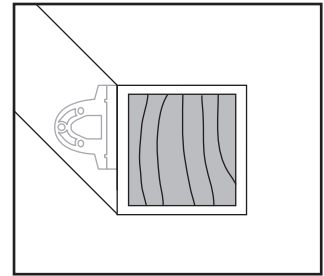

TREX SELECT® STAIR RAILING

IMPORTANT NOTES:

- » TREX SELECT RAILINGS ARE DESIGNED TO BE INSTALLED OVER THE DECKING FRAME OR ON INSIDE OF RIM JOIST. NOTCHING OF PRESSURE-TREATED POSTS OR POSTS INSTALLED ON OUTSIDE OF RIM JOIST IS NOT ALLOWED.
- » POST TO POST SPAN WILL BE LESS THAN 6' OR 8'. PRIOR TO INSTALLING POSTS CALCULATE POST TO POST SPAN USING A MAXIMUM RAIL LENGTH REQUIRED AND THE ANGLE (32°-37°) AT WHICH THE RAILS WILL BE INSTALLED. DO NOT INSTALL STAIR POSTS AT 6' OR 8' SPAN, AS STAIR RAILINGS WILL THEN BE TOO SHORT.

Care and Cleaning

Maintaining the appearance of your Trex Select railing is important. The occasional wash is recommended as over time your railing may show signs of weathering as a result of exposure to the elements. The frequency of cleaning will depend on the environment and exposure to various types of elements.

- » Clean railing using a standard cleaning vinegar or mild soap and water.
- » For more detailed cleaning recommendations please refer to the Trex Railing Care and Cleaning guide found on www.trex.com.

PARTS

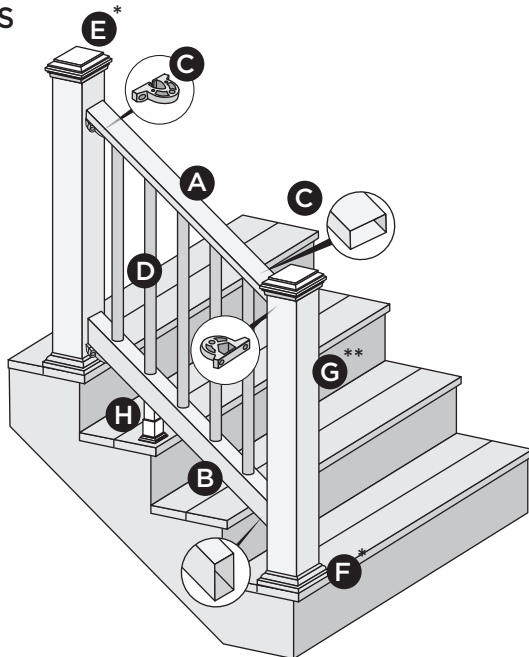

- A. Select Stair Top Rail
- B. Select Stair Bottom Rail
- C. Brackets
- D. Round Balusters
- E. Post sleeve cap*
- F. Post sleeve skirt*
- G. Post sleeve - 4" x 4" (102 mm x 102 mm) or 6" x 6" (152 mm x 152 mm)**
- H. Adjustable foot block (quantity of one is required for all railing span lengths)

* Item not included in the Select railing kits.

** Both 4" x 4" (102 mm x 102 mm) and 6" x 6" (152 mm x 152 mm) post sleeves are designed to fit over 4x4 pressure-treated post.

DETERMINING BALUSTERS NEEDED

Baluster Type	Per 6' OC Section	Per 8' OC Section
Round Aluminum Baluster(Stair Application)	12	16

NOTES:

- » In most cases, a post and post sleeve longer than 39" (991 mm) will be needed on the lower section of stair rail to accommodate stair angle.
- » Make sure top and bottom posts for stairs are installed at nose of each tread.
- » Ensure pressure-treated posts are installed at proper heights so when post sleeves are installed, both the PT post and post sleeve are flush at top.
- » See specific installation instructions for attachment of Trex post mounts or Trex Joist Mount Posts prior to installing any railing.

Screws Supplied with Brackets

- C1. Wood screw for attachment of bracket to wood post/composite sleeve
- C2. Self-drilling rail screw for attachment of railing to bracket

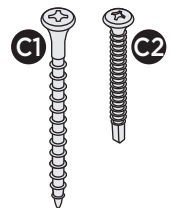

TREX SELECT® STAIR RAILING CONFIGURATIONS

Note: See specific installation instructions for attachment of Trex Post Mounts or Trex Joist Mount Posts prior to installing any railing.

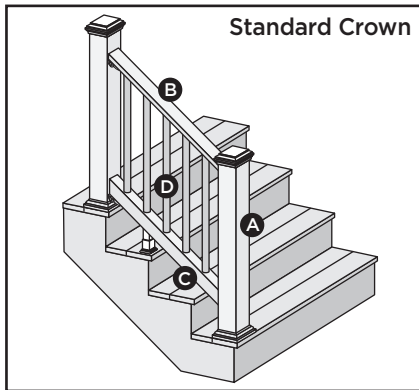

- Cutting post sleeves is **NOT** required.
- A. Pressure-treated post/Trex post sleeve, Trex post mount/Trex post sleeve, or Joist Mount Post/Trex post sleeve (INSIDE MOUNT ONLY)
 - B. Select Stair top rail
 - C. Select Stair bottom Rail
 - D. Round Aluminum Balusters
- See page 202 for "How to Install Standard Stair Railing".

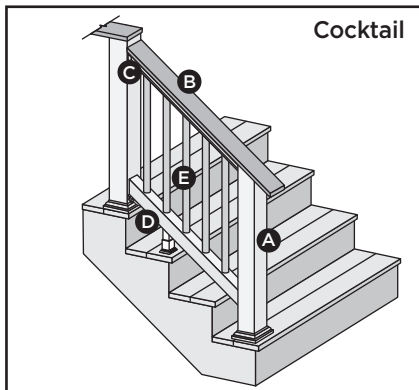

- Post sleeves **WILL NEED TO BE CUT.**
- A. Pressure-treated post with Trex post sleeve
NOTE: » Only for use with 4" x 4" (102 mm x 102 mm) post sleeve
» Trex post mounts or joist mount posts cannot be used with Select Stair cocktail design
 - B. Deck board top rail (1 x 6 or 2 x 6). **NOTE:** Enhance cannot be used.
 - C. Select Stair top rail
 - D. Select Stair bottom rail
 - E. Round Aluminum Balusters
- See page 205 for "How to Install Cocktail Stair Railing".

POST SLEEVES WILL NEED TO BE CUT

NOTE: Additional pan head screws will need to be purchased-see detailed instructions.

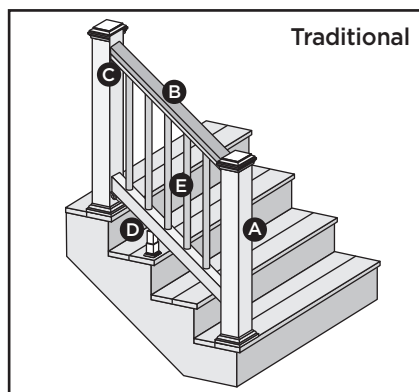

- Cutting post sleeves is **NOT** required.
- A. Pressure-treated post/Trex post sleeve, Trex post mount/Trex post sleeve, or Joist mount post/Trex post sleeve (INSIDE MOUNT ONLY)
 - B. 2 x 4 ateral top rail
 - C. Select Stair top rail
 - D. Select Stair bottom rail
 - E. Round Aluminum Balusters
- See page 207 for "How to Install Traditional Stair Railing".

NOTE: Additional pan head screws will need to be purchased - see detailed instructions.

HOW TO INSTALL STANDARD STAIR RAILING

TREX SELECT®

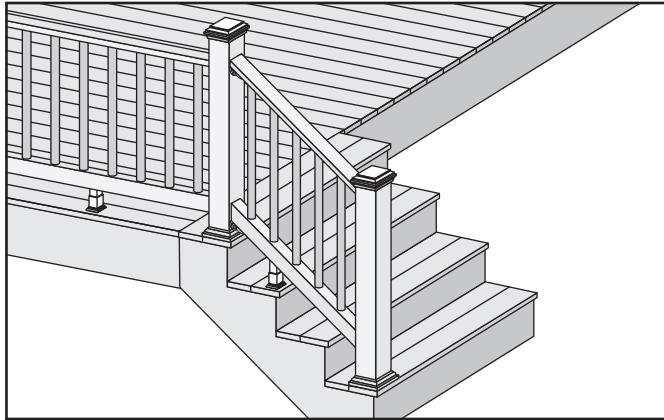

Installing Pressure-Treated Posts

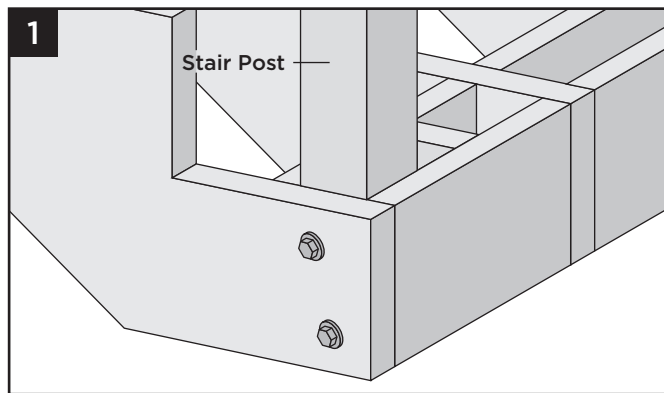

- » **PLEASE REFER TO LOCAL BUILDING CODE REQUIREMENTS PRIOR TO ATTACHING PRESSURE TREATED POSTS.**
- » **PRESSURE TREATED POSTS MUST BE INSTALLED ON INSIDE OF STAIR STRINGER AND AT NOSE OF STAIR TREAD.**
- » **POST TO POST SPAN WILL BE LESS THAN 6' OR 8'. PRIOR TO INSTALLING POSTS CALCULATE POST TO POST SPAN USING A MAXIMUM RAIL LENGTH REQUIRED AND THE ANGLE (32°-37°) AT WHICH THE RAILS WILL BE INSTALLED. DO NOT INSTALL STAIR POSTS AT 6' OR 8' SPAN, AS STAIR RAILINGS WILL THEN BE TOO SHORT.**
- » *Attach posts using code approved hardware and also use added blocking.*
- » *Bolts can be countersunk flush with framing to allow for fascia attachment.*
- » *In most cases, a post and post sleeve longer than 39" (991 mm) will be needed on the lower section of stair rail to accommodate stair angle.*

NOTE: Blocking can be added for extra strength.

Installing Post Sleeve Skirts and Post Sleeves

2. Slide post sleeve skirt over post and down to rest on decking surface. Slide post sleeve over post and position inside post sleeve skirt.

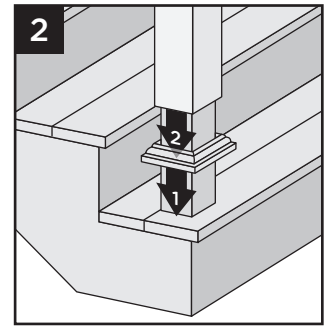

NOTE: Shims can be used to plumb post sleeves.

Measuring and Cutting Bottom Rail

3. Place a 1" (2.5 cm) deckboard on the nose of the stair tread.

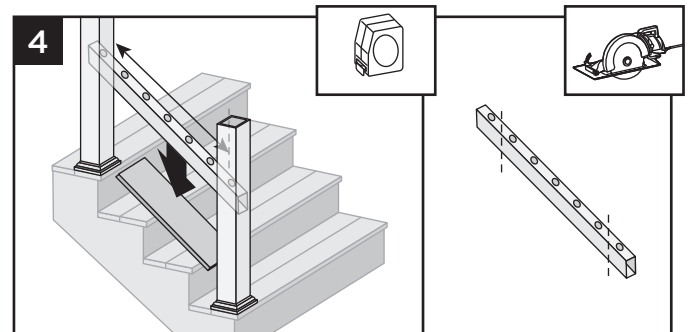
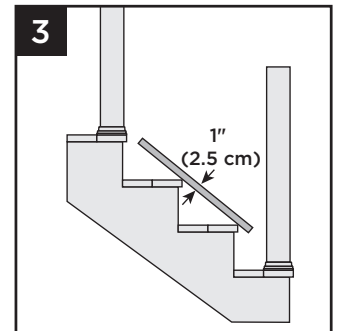

4. Set railing on top of deckboard, making sure baluster holes are vertically aligned and mark line at each intersection. **When measuring, cut equal lengths from each side of railing allowing a minimum of 2" (51 mm) on each end from the last baluster hole to the end of the rail.** This will ensure proper baluster and bracket placement and equal spacing of balusters per each railing section.

IMPORTANT NOTE REGARDING FOOT BLOCK INSTALLATION:

- » Refer to detailed instructions (Trex Select rail instructions) included with foot block prior to installation of railing section as these include other required steps for proper installation.

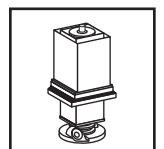

HOW TO INSTALL STANDARD STAIR RAILING/CONTINUED

TREX SELECT®

Marking Location for Foot Block to Bottom Rail

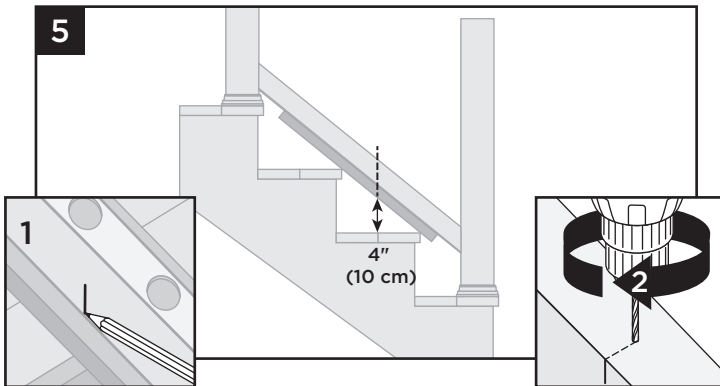

5. Mark approximate location for foot block, allowing a measurement of 4" maximum. Invert the bottom rail, and at marked location drill a hole using a 3/16" drill bit in the center of the channel. Foot block is to be installed at last step.

Attaching Brackets to Bottom Rail

6. Snap the top stair adaptor bracket (labeled TOP) to the standard bracket. Repeat for remaining bottom bracket.

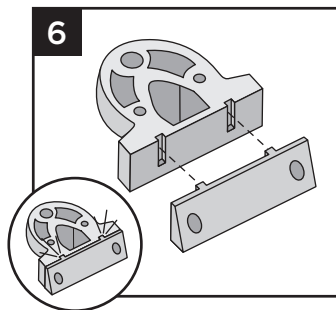

TIP: Use a dab of super glue when snapping bracket together. This will help stabilize bracket when installing.

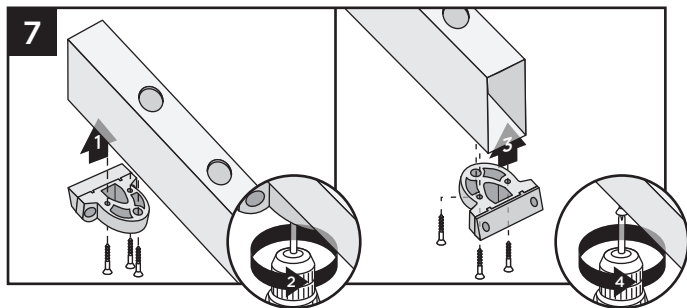

7. On the BOTTOM RAIL, attach the assembled bottom stair brackets to the OPPOSITE SIDE of the baluster holes. Attach both brackets using three #8-18x1" selfdrilling screws (provided).

Attachment of Bottom Rail to Post

NOTE: For attachment of brackets to posts, use at least a 3" long drill bit or extension so as to not damage sides of rails when installing.

TIP: Pre-drill prior to screw installation using a 7/64" drill bit

8a. Keeping deck board on stair treads, center bottom rail between posts and attach bottom rail stair bracket to upper post using two #8-10 x 3" wood screws (provided).

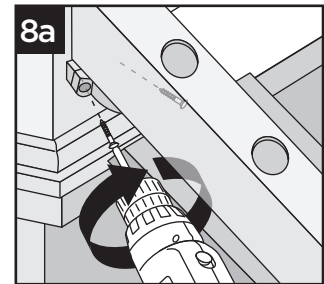

8b. Attach bottom stair rail stair bracket to lower post using two #8 10 x 3" wood screws (provided). (deck board can now be removed).

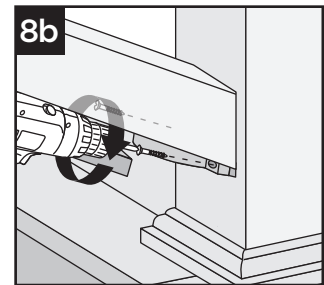

IMPORTANT NOTE:
SET DRILL TO LOW SPEED AND LOW CLUTCH SETTING WHEN INSTALLING THESE SCREWS. DO NOT USE IMPACT DRIVER.

Measuring and Cutting Top Stair Rail

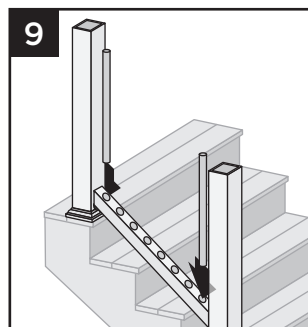

9. Place two balusters into lower stair rail at each end closest to the post.

10. Position top stair rail onto balusters, ensuring balusters are fully seated in rail (position to side of post), and ENSURE balusters are spaced evenly AND parallel with posts.

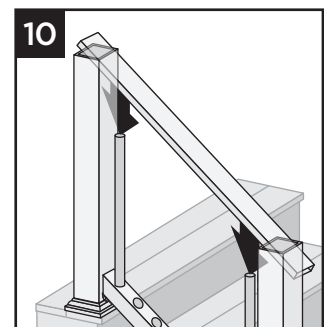

HOW TO INSTALL STANDARD STAIR RAILING/CONTINUED

TREX SELECT®

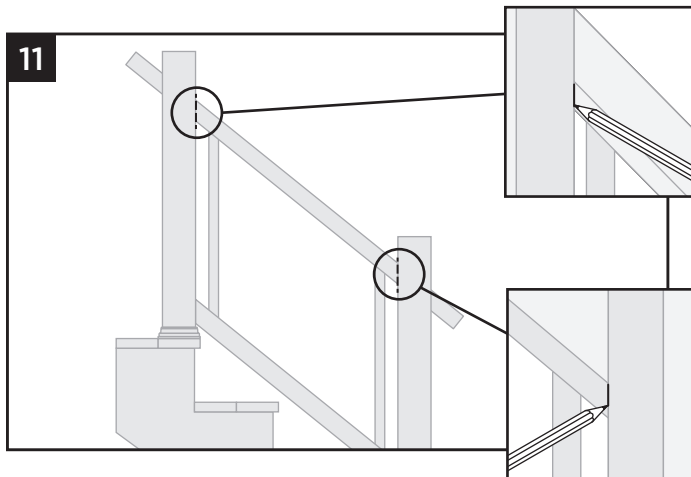

11. Mark top stair rail at post intersections.

12. Remove rail, and cut along the marks.

NOTE: Verify the height of the railing before installing rail to post to ensure this meets proper height requirements for stairs.

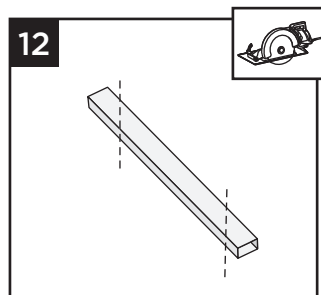

Attaching Brackets on Top Stair Rail

13. Snap the top stair adaptor bracket (labeled TOP) to the standard bracket. Repeat for remaining bracket.

TIP: Use a dab of super glue when snapping bracket together. This will help stabilize bracket when installing.

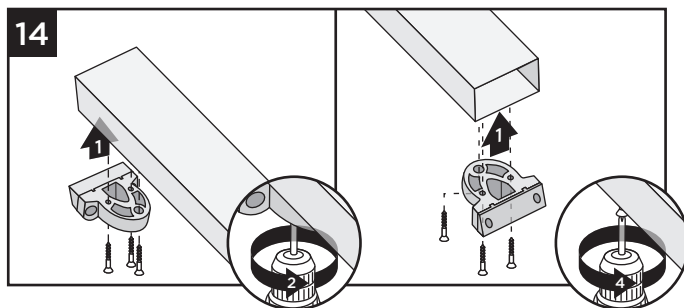
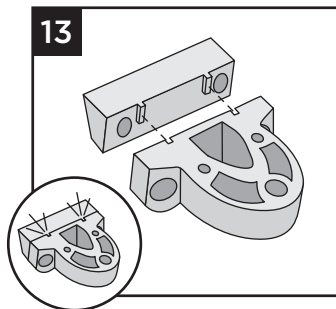

14. On the TOP RAIL, attach the assembled stair brackets to the side WITH the baluster holes. Attach both brackets using three #8-18x1" self-drilling screws (provided).

Installing Balusters

15. Slide remaining balusters into bottom rail until balusters are fully seated.

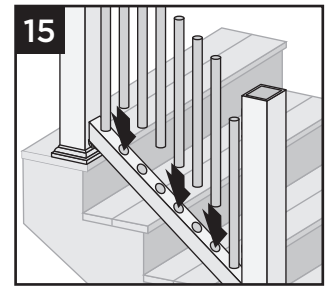

Attachment of Top Rail to Post

16. Place top rail onto balusters, allowing the top rail to rest on the surface of the balusters.

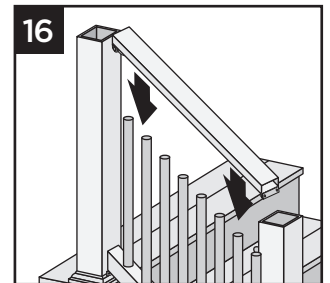

NOTE: For attachment of brackets to posts, use at least a 3" long drill bit or extension so as to not damage sides of rails when installing.

TIP: Pre-drill prior to screw installation using a 7/64" drill bit

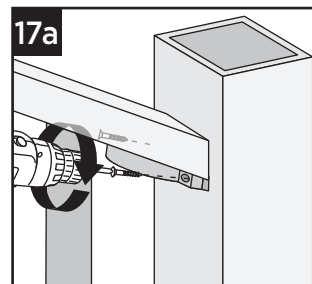

17a. Attach top stair rail bracket to upper post using two #8-10 x 3" screws (provided).

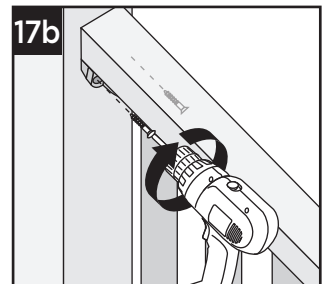

17b. Attach top stair rail bracket to lower post using two #8-10 x 3" screws (provided).

IMPORTANT NOTE:

SET DRILL TO LOW SPEED AND LOW CLUTCH SETTING WHEN INSTALLING THESE SCREWS. DO NOT USE IMPACT DRIVER.

Attaching Post Caps and Installing Foot Block

18. Secure post caps with silicone or PVC adhesive (apply adhesive on the inside self-centering/corner tabs). Attach foot block per foot block instructions.

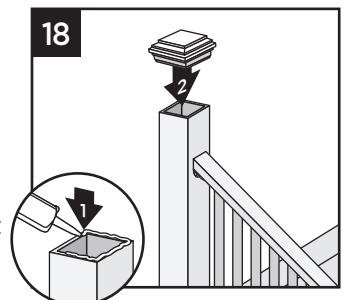

NOTE: Clean up any excess adhesive before it dries.

HOW TO INSTALL COCKTAIL STAIR RAILING TREX SELECT®

IMPORTANT NOTES:

- » Only for use with pressure-treated 4 x 4 post (3.5" nominal square) and 4" x 4" (102 mm x 102 mm) post sleeve. Trex post mounts or joist mount posts cannot be used with Trex Select stair cocktail. Cutting post and post sleeve only apply to the Cocktail style railing.
- » THE DECK BOARD USED IN SELECT STAIR COCKTAIL RAILING WILL NEED TO TERMINATE AT THE UPPER STAIR POST AS SHOWN BELOW. THE DECK BOARD WILL HAVE TO BE TOENAILED INTO THE SIDE OF THE POST IN THESE AREAS USING 2 APPROPRIATE COMPOSITE DECKING SCREWS - PRE-DRILLING IS RECOMMENDED.

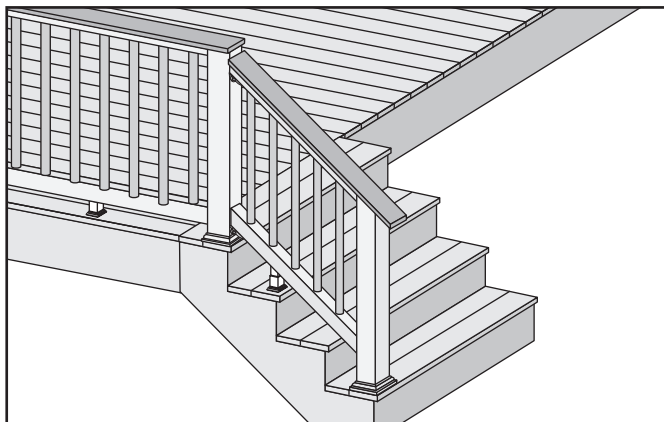

1. **Installing Pressure-Treated Posts**
See instructions on page 202.
(See note above in regards to not cutting post/post sleeve).
2. **Installing Post Sleeve Skirts and Post Sleeves**
See instructions on page 202.
3. **Measuring and Cutting Bottom Stair Rail**
See instructions on page 202.
4. **Marking Location for Foot Block to Bottom Rail**
See instructions on page 203.
5. **Attaching Brackets to Bottom Rail**
See instructions on page 203.
6. **Attachment of Bottom Rail to Post**
See instructions on page 203.
7. **Measuring and Cutting Top Stair Rail**
See instructions on page 203.

Cutting Post and Post Sleeve

8. Cut lower post/post sleeve at proper angle so this is flush with the top of the top rail.

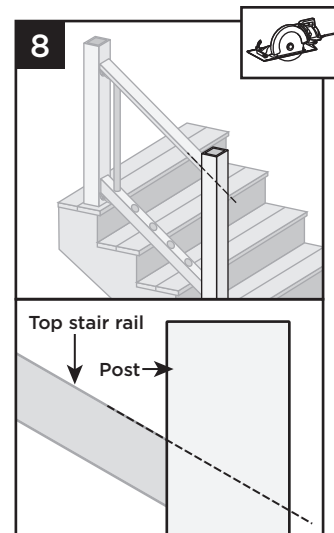

9. Attaching Brackets on Top Stair Rail

See instructions on page 204.

Measuring and Cutting Deck Board

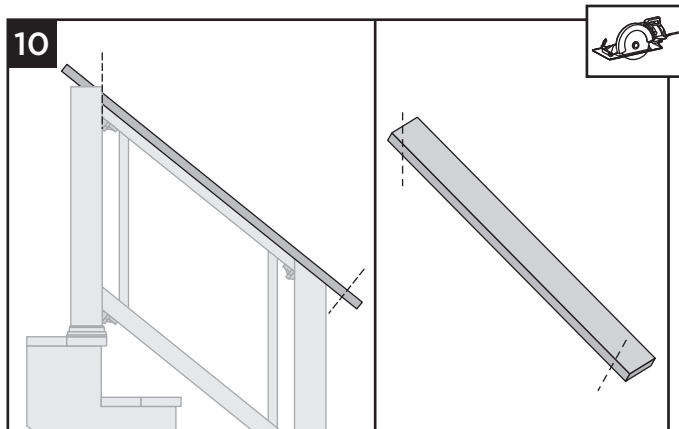

10. Measure accordingly and cut deck boards to appropriate length of railing span also allowing for additional decking material that will be installed over the lower stair rail post.

Attaching Deck Board to Select Top Stair Rail

11. Place inverted deck board (place top side of deck board down) on clean, flat surface.

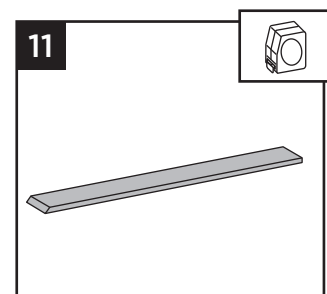

HOW TO INSTALL COCKTAIL STAIR RAILING/CONTINUED TREX SELECT®

Attaching Deck Board to Select Top Rail

12. Place inverted Select top rail (orient properly so baluster holes are shown top side up), on the deck board so the angled cuts will align properly along with centering the top rail on the deck board.

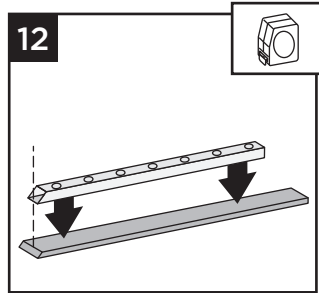

13. Secure deck board to Select top rail with 3/4" screws provided approximately every 16" on center. Screws are to be installed inside of the baluster holes into the decking board.

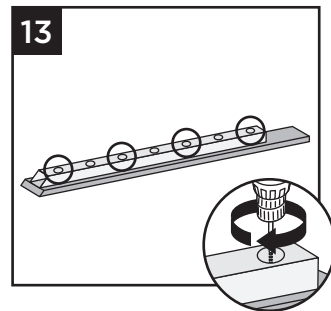

NOTES:

- » **DO NOT** overtighten.
- » Note that a long drill bit will be required to fit inside the baluster holes.
- » If installing 8' rail section and using the Aluminum Rail Stiffener, predrilling will be required through the stiffener.

14. Installing Balusters

See instructions on page 204.

15. Attachment of Top Rail to Post

See instructions on page 204.

Attachment of Deck Board to Post

16. Attach deck board to lower post with Trex-recommended composite screws (quantity of 2 per each post/board end).

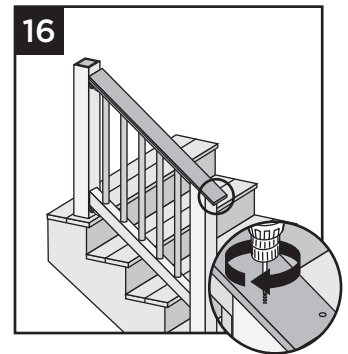

17. Where deck board terminates at upper post, PREDRILL and toenail two approved composite deck screws as shown into post, being careful to avoid hitting stair bracket.

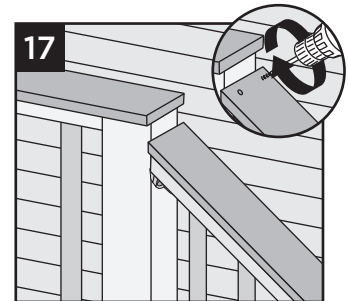

Installation of Foot Block

18. Attach foot block per foot block instructions.

HOW TO INSTALL TRADITIONAL STAIR RAILING

TREX SELECT®

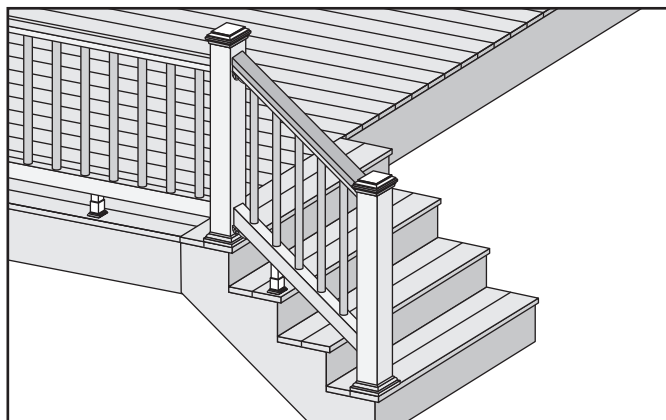

1. **Installing Pressure-Treated Posts**
See instructions on page 202.
2. **Installing Post Sleeve Skirts and Post Sleeves**
See instructions on page 202.
3. **Measuring and Cutting Bottom Stair Rail**
See instructions on page 202.
4. **Marking Location for Foot Block to Bottom Rail**
See instructions on page 203.
5. **Attaching Brackets to Bottom Rail**
See instructions on page 203.
6. **Attachment of Bottom Rail to Post**
See instructions on page 203.
7. **Measuring and Cutting Top Stair Rail**
See instructions on page 203.

Measuring and Cutting 2 x 4

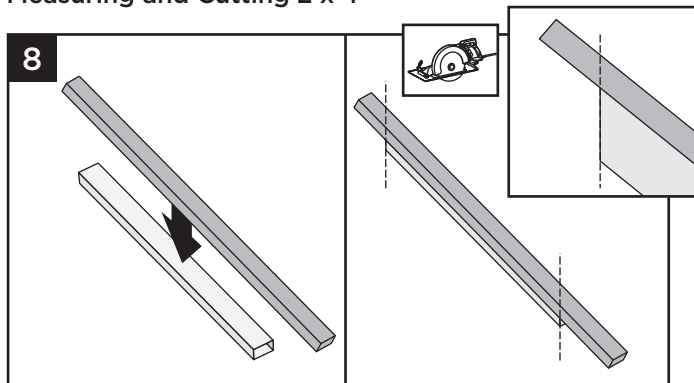

8. Using the cut top rail as template, cut 2 x 4 at same angle and length of the top rail.

9. **Attaching Brackets on Top Stair Rail**
See instructions on page 204.

Attaching 2 x 4 to Select Top Rail

11. Place inverted 2 x 4 (top side face down) on clean, flat surface.

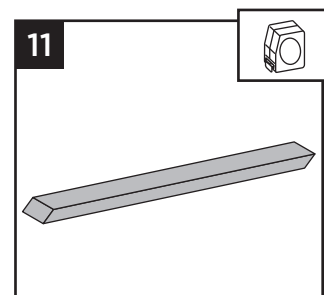

12. Place inverted Select top rail (orient properly so baluster holes are shown top side up) on 2 x 4.

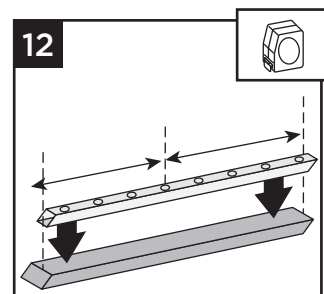

13. Secure 2 x 4 to Select top rail with 3/4" screw provided approximately every 16" on center. Screws are to be installed inside of the baluster holes into the 2 x 4.

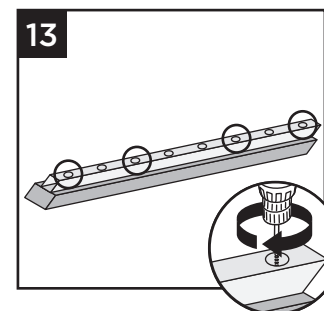

NOTES:

- » **DO NOT** overtighten.
- » Note that a long drill bit will be required to fit inside the baluster holes.
- » If installing 8' rail section and using Aluminum Rail Stiffener, predrilling will be required through the stiffener.

14. **Installing Balusters**
See instructions on page 204.
15. **Attachment of Top Rail to Post**
See instructions on page 204.

HOW TO INSTALL TRADITIONAL STAIR RAILING/CONTINUED TREX SELECT[®]

Attaching 2x4 to Post

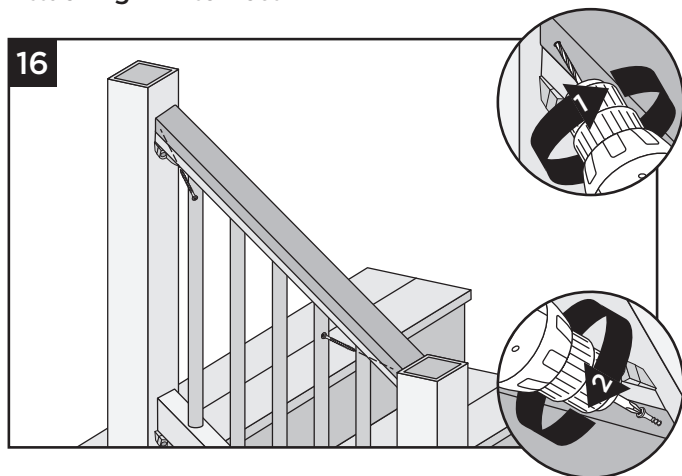

16. Pre-drill a pilot hole and toenail 2-1/2" (6.4 cm) composite deck screw at each end of 2 x 4 into post on outside of stair rail (side not facing decking).

17. Attaching Post Caps and Installing Foot Block

See instructions on page 204.

TREX® ALUMINUM ADA COMPLIANT HANDRAIL

STAIR APPLICATION

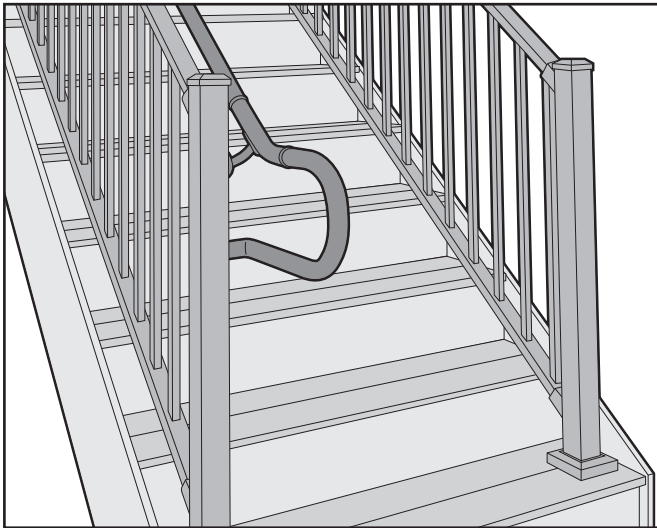

RAMP APPLICATION

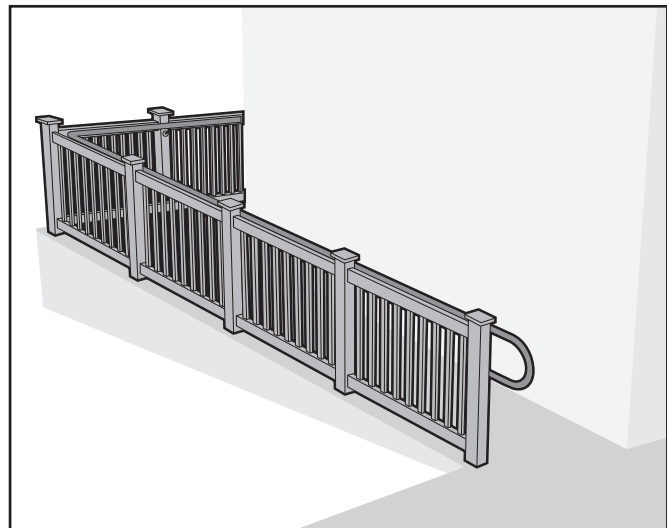

ADA Handrail Guidelines

1. ADA handrails can be installed using various design applications such as those for stairs, ramps, and horizontal applications. Designs include options for straight and 90° wall returns, 90° corners, and adjustable angles. Choose which is best for your needs before installing. Refer to railing profile page for a more detailed parts list.

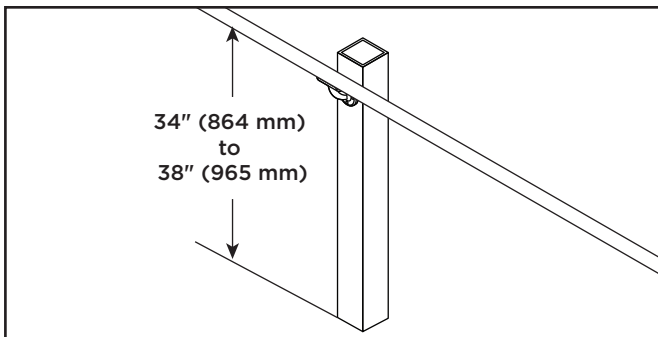

2. The handrail system top rail should be 34" (864 mm) to 38" (965 mm) above the surface. However, verifying height requirements with local building code officials before installing is important as codes vary in different areas.*
3. Maintain a minimum clearance of 1-1/2" (38 mm) between the handrail and any obstructions above or behind the handrail.
4. The end loop return at all landings must extend 12" (305 mm) past the end of the ramp or stair application.*
5. The slope of the handrail for the ramp should not exceed 1" (25 mm) rise over a 12" (305 mm) run.

6. The maximum recommended span between supports is 6' (1.83 m) on center. Thus, placement of posts is critical when installation of railing is being considered.*

7. Rails are designed to have a tight fit into other connecting components. It is critical to line these up in the correct orientation BEFORE connecting parts together. If it is necessary to shift or move a component on a rail, wrap with a protective cloth to prevent scratching as you may need to use a wide-mouth wrench to correct this.
8. At any straight location where internal connector is used, it is CRITICAL to locate these as close to a wall mount as possible.
9. If using metal posts, pre-drill all locations for bracket attachment. (ALWAYS use a drill bit slightly SMALLER in diameter than the screw being used for attachment.)
10. All elbow components can be cut down to allow for tighter angles. Cut a maximum of 2" (51 mm) on each side if this is required.



*Refer to the American Disabilities Act for detailed information with regard to handrail requirements.



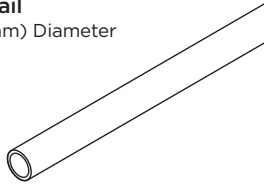

SAFETY NOTES

- » When cutting metal, ALWAYS wear proper safety eyewear (as well as any other proper safety wear).
- » Remove all burrs from cut ends before installation.
- » Use of a non-ferrous metal blade is recommended.

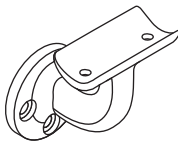
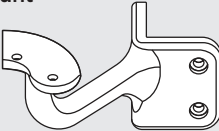
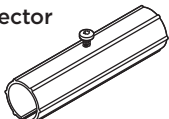
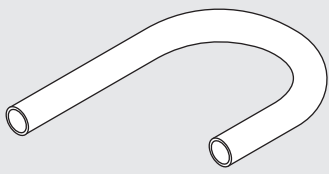
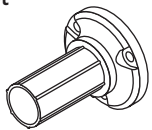

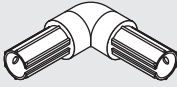
ADA RAILING PROFILES

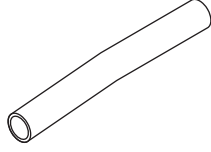
» SEE PAGE 55 FOR SKU NUMBERS.

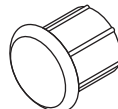
DESCRIPTION	COLOR
ADA Handrail 1.375" (34.9mm) Diameter 	BK, BZ, WT
ADA Wall Return (screws included) 	BK, BZ, WT
ADA Wall Mount (screws included) 	BK, BZ, WT
ADA Corner Mount (screws included) 	BK, BZ, WT
ADA Internal Connector 	
ADA Handrail Return 	BK, BZ, WT
ADA Inline Bracket (screws included) 	BK, BZ, WT

DESCRIPTION	COLOR
ADA Adjustable Elbow 	BK, BZ, WT
ADA 90° Elbow*  <small>*This component is designed for both inside corners and outside corners.</small>	BK, BZ, WT
ADA 36°, 34°, and 31° Elbows 	BK, BZ, WT
ADA 5° Elbow 	BK, BZ, WT
ADA Collar 	BK, BZ, WT
ADA End Cap 	BK, BZ, WT

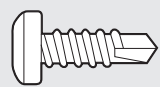
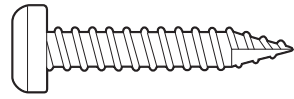
HARDWARE

RAIL TO BRACKET ATTACHMENT	
Short Metal Screw (#10 x 5/8" [16 mm])	
BRACKET TO METAL POST ATTACHMENT	
Long Metal Screw (#12 x 1-1/4" [32 mm])	
BRACKET TO WOOD POST/POST SLEEVE ATTACHMENT	
Wood Screw (#10 x 2" [51 mm])	

NOTE: If attaching brackets to 6x6 posts/postsleeves, use #10 x 2-1/2" (64 mm) wood screws (not included).

COLORS: BK Charcoal Black BZ Bronze WT White



HOW TO INSTALL TREX® ALUMINUM ADA COMPLIANT HANDRAIL

90° Wall Return

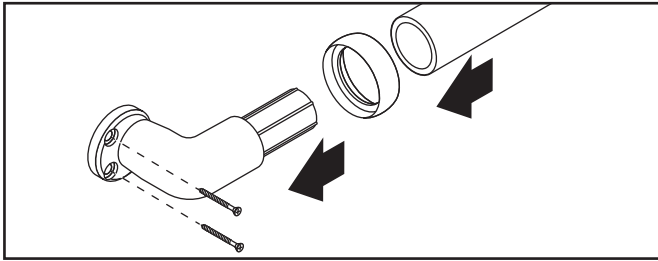

1. If required, cut railing to proper length based on location of wall return(s) or attachment to other components.
2. If desired, collar ring can be used to hide seam of wall return to rail. Slide over rail **BEFORE** inserting rail into wall return.
3. Slide rail onto wall return until it is fully inserted and seam is hidden under collar (if collar is being used).
4. Attach wall return to post using specific hardware provided (see chart on previous page), **ENSURING** wall return is at proper angle of alignment to post. (Wall return is designed to have tight fit into rail, thus location of attachment is critical.) If using metal posts, pre-drill post prior to attachment of wall mount.

Wall Mount

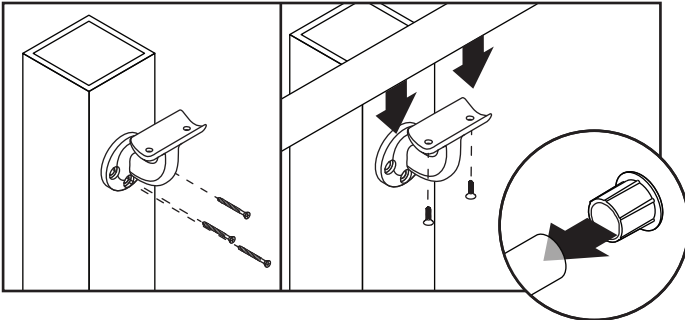

NOTE: Refer to Rail-to-Rail Connections section if connecting two or more rails together to make continuous straight run.

1. If required, cut railing to proper length based on location of wall mount(s) or attachment to other components.
 2. Attach wall mount to post using specific hardware provided (see chart on previous page), **ENSURING** wall mount is at proper angle of alignment to angle of rail. If using metal posts, pre-drill post prior to attachment of wall mount.
- TIP:** To help with angled attachment, place one screw into bottom hole of bracket and pivot wall mount to position required.
3. Attach rail to wall mount using specific hardware provided (see chart on previous page).
 4. Attach end cap to railing.

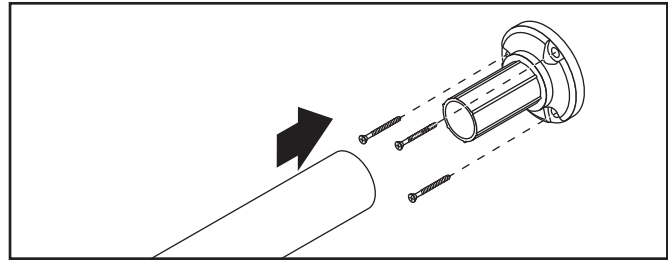

Inline Bracket

1. If required, cut railing to proper length based on location of inline bracket(s) or attachment to other components.
2. Attach inline bracket to post using specific hardware provided (see chart on previous page). If using metal posts, pre-drill post prior to attachment of inline bracket.
3. Slide rail onto inline bracket until it is fully inserted.

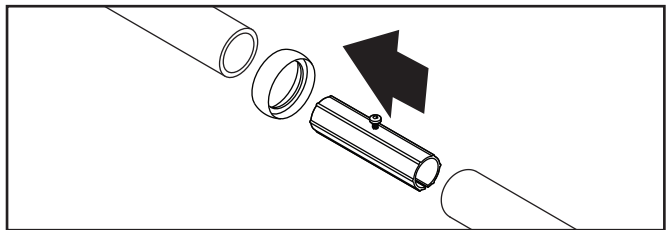

Rail-to-Rail Connections/Internal Connector

NOTE: When rail-to-rail straight connections are used for longer spans, posts must be installed 6' OC max. In addition, a wall mount **MUST** be used at each seam of rail-to-rail connections as close to center of wall mount as possible. If collar is used, this can be offset slightly to allow for the collar to fit.

1. If required, cut railing to proper length.
2. If desired, collar ring can be used to hide seam between rails. Slide ring over rail **BEFORE** inserting rails into internal connector.
3. Slide internal connector into rail end until metal spacer screw is touching either end of rail or collar, if used.
4. Slide second rail over opposite end of internal connector, until it is touching metal spacer screw.
5. Remove metal spacer screw using #2 square-head screwdriver.
6. Push second rail further over internal connector until it fits in the collar (if used) or fits tightly against rail.
7. Attach wall mount to post per previous instructions.
8. Attach rail to wall mount per previous instructions.
9. Use end caps where required.

HOW TO INSTALL TREX ALUMINUM ADA COMPLIANT HANDRAIL/*CONTINUED*

Handrail Return 180°

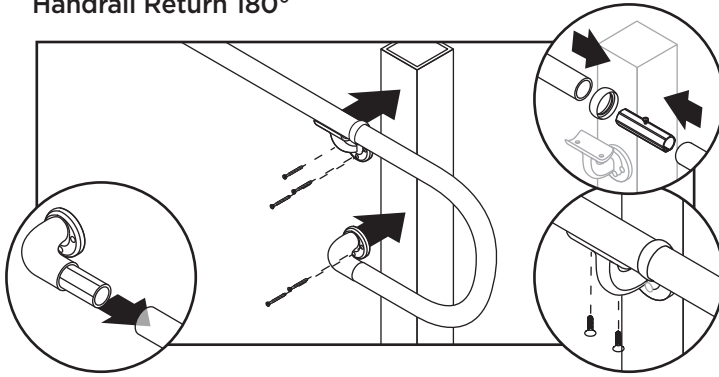

NOTE: Ramp application shown here. (Appropriate angle elbow also required for stair applications.)

1. If required, cut railing to proper length based on location of elbow used as well as other components being used.
2. If desired, collar ring can be used to hide seam of handrail return to rail or elbow being used. Slide this over rail **BEFORE** inserting rail into other component.
3. Ensure that all components are aligned to both wall mount on post as well as location of elbow on rail **BEFORE** attachment.
4. Slide internal connector into appropriate elbow being until metal spacer screw is touching either end of elbow or the collar, if this was used.
5. Attach wall return to lower end of handrail return (longer side), **ENSURING** wall return is at proper angle of alignment to post. (Wall return is designed to have tight fit into rail, thus location of attachment is critical.)
6. Slide opposite end of handrail return onto internal connector, until it is touching metal spacer screw.
7. Remove metal spacer screw using #2 square-head screwdriver.
8. Push handrail return further over internal connector until it fits in the collar (if used) or fits tightly against elbow.
9. Attach wall return to post per previous instructions.
10. Attach rail to wall mount per previous instructions.
11. Use end caps where required.

Adjustable Elbow

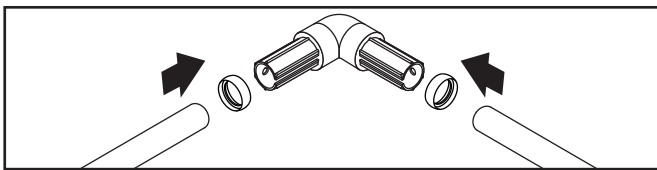

NOTE: This elbow is designed to take the guesswork out of which elbow to buy based on stair angle.

1. If required, cut railing to proper length based on location of elbows and other components being used.
2. If desired, collar ring can be used to hide seam of adjustable elbow to rail. Slide over rail **BEFORE** inserting rail into adjustable elbow.
3. Slide adjustable elbow into rail and ensure this fits tightly against rail.

4. Determine angle required and tighten set screw on adjustable elbow. (It is recommended to do this before final attachment in order to access the set screw more easily.)
5. Slide other connector of adjustable elbow into the 180° handrail return or transition rail.

Elbows (90°, 36°, 34°, 31°, 5°)

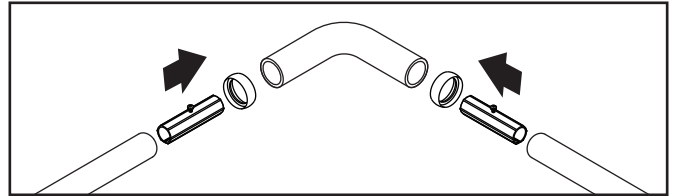

1. If required, cut railing to proper length based on location of elbows and other components being used.
2. If desired, collar ring can be used to hide seam of elbow to rail. Slide over rail **BEFORE** inserting rail into elbow.
3. Slide internal connector into rail end until metal spacer screw is touching either end of rail or the collar, if this was used.
4. Slide appropriate angled elbow onto opposite end of internal connector, until it is touching metal spacer screw.
5. Remove metal spacer screw using #2 square head screwdriver.
6. Push elbow further over internal connector until it fits in the collar (if used) or fits tightly against rail.
7. Attach wall mount to post per previous instructions.
8. Attach rail to wall mount per previous instructions.

Corner Mount

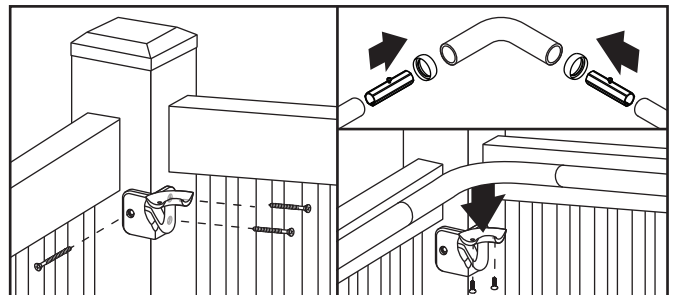

1. Pre-drill metal post and install corner post to metal post using specific hardware provided (see chart on previous page).
2. If desired, collar ring can be used to hide seam of elbow to rail. Slide this over rail **BEFORE** inserting rail into elbow.
3. Slide internal connector into rail end until metal spacer screw is touching either end of rail or the collar, if this was used.
4. Slide appropriate angled elbow onto opposite end of internal connector, until this is touching metal spacer screw.
5. Remove metal spacer screw using #2 square-head screwdriver.
6. Push elbow further over internal connector until this fits in the collar (if used) or fits tightly against rail.
7. Install elbow to corner mount using specific hardware provided.

NOTE: Construction methods are always improving. Please refer to www.trex.com for the most up-to-date installation requirements.

CLADDING

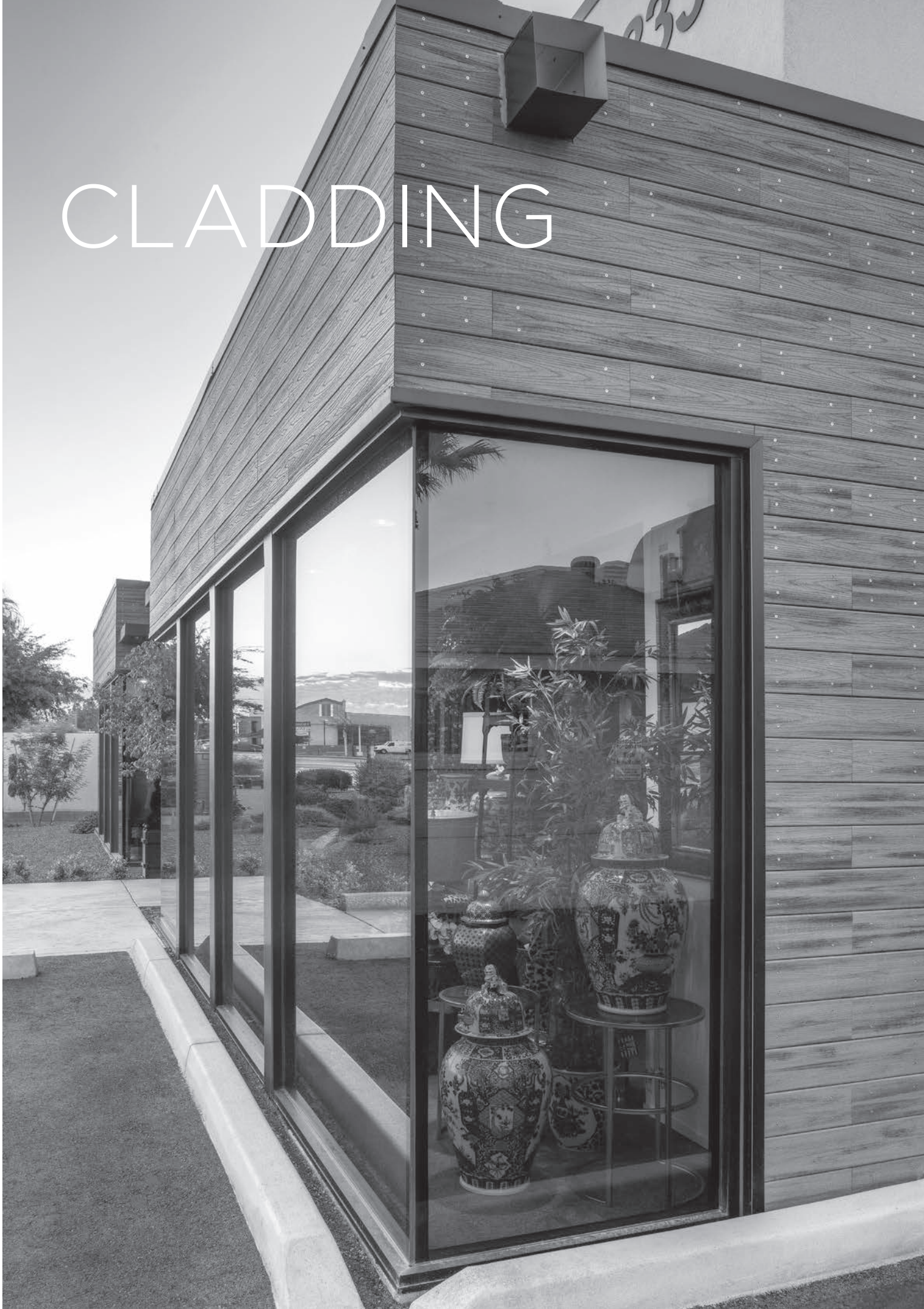

TRANSCEND CLADDING

HOW TO INSTALL OPEN-JOINT CLADDING

TREX TRANSCEND®

TOOLS NEEDED

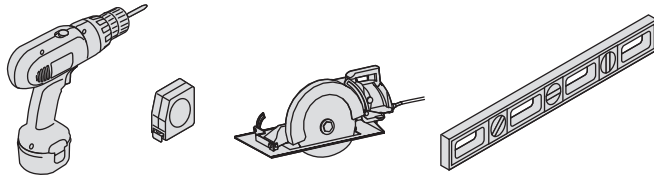

NOTES:

- » Only Trex Transcend square edge profiles are approved for use in cladding applications.
- » Consult local building code officials regarding applicable requirements of cladding applications, including that of proper methods of attachment of cladding framing supports.
- » Always install wood or steel furring strips over a flat substrate or a suitable cladding substructure.
- » Ensure that proper gapping requirements are followed as listed within instructions.
- » Open-joint facades are permitted when following Trex Cladding install instructions.

TREX-APPROVED PRODUCT FOR CLADDING APPLICATIONS:

PROFILE	DESCRIPTION	ITEM NUMBER	COLORS	
Trex Transcend 1" Square-Edge Board <i>Actual dimensions:</i> Transcend: 94 in x 5.5 in x 12 ft / 16 ft / 20 ft (24 mm x 140 mm x 365 cm / 487 cm / 609 cm)	1 x 6 x 12'	Transcend Tropicals	IM, TT, HG, SR, LR	
	1 x 6 x 16'	Transcend Tropicals		
	1 x 6 x 20'	Transcend Tropicals		
	1 x 6 x 12'	Transcend Earth Tones	XX010612T2S01	GP, RS, VL
	1 x 6 x 16'	Transcend Earth Tones	XX010616T2S01	
	1 x 6 x 20'	Transcend Earth Tones	XX010620T2S01	

Approved Fasteners:

NOTE: The fasteners listed below are all approved fasteners for attachment of Trex Cladding to furring strips. Consult local building code official for proper fasteners to use when attaching furring strips to structural wall. For salt water applications, it is recommended to use wood furring strips with appropriate stainless steel screws.

If any condition occurs which is attributable to the use of non-recommended fasteners, such condition shall not be covered under the Trex Limited Warranty.

Cladding Attachment to Wood Furring Strips:

- » Starborn® Cap-Tor® xd Epoxy Coated & Headcote® 305 Stainless 2" **ONLY**.
- » Starborn Deckfast® Fascia System -Epoxy Coated & Headcote® 305 Stainless.
- » Starborn® Pro Plug® System for PVC and Composite (Epoxy Coated & 305 or 316 Stainless) 2" **ONLY**.

Cladding Attachment to Steel Furring Strips:

- » Starborn® Pro Plug® System for PVC and Composite for Metal Framing (410SS, self-drilling).
- » Starborn Deckfast® Metal 410SS with Epoxy Coating.

Gapping and Overhang:

You must gap Trex cladding both end-to-end and width-to-width. Gapping is necessary for airflow and the slight thermal expansion and contraction of Trex cladding boards.

- » **ALWAYS** follow Trex recommended gapping guidelines.
- » Maximum allowable perpendicular overhang for all Trex decking is 3/4".

WIDTH-TO-WIDTH GAP
3/16" Min.

END-TO-END/END-TO-WIDTH AND ABUTTING GAP		
	End-to-End/ End-to-Width	Abutting Solid Objects
Above 40°F* (4.5°C)*	1/8"	1/4"
Below 40°F* (4.5°C)*	3/16"	1/2"

*Temperature at installation

Pro Plug®, DeckFast®, Cap-Tor® xd and HeadCote® are registered trademarks of Starborn Industries Inc.

FASTENING TIPS

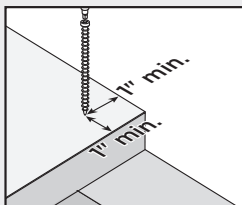

Install fasteners at a 90° angle (perpendicular to the board).

Install screws at minimum of 1" (25 mm) from the board end and edge, without splitting the board.

HOW TO INSTALL OPEN-JOINT CLADDING/CONTINUED

TREX TRANSCEND®

WOOD FURRING STRIPS (Pressure-Treated Wood)

Minimum 1-1/2" x 1-1/2"

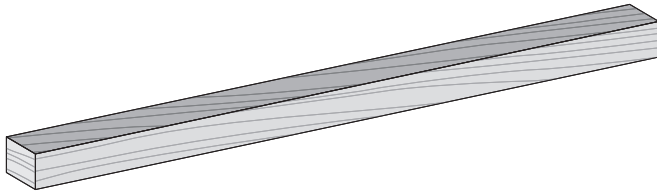

1-1/2" x 3-1/2"

Used for butt joint applications

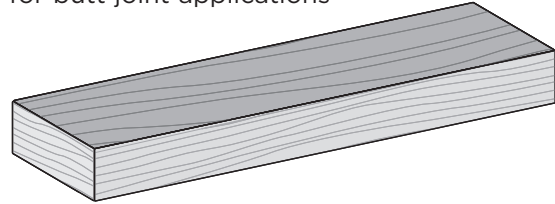

- » Install furring strips at a maximum of 24" on center.
- » Use two approved fasteners for attaching cladding to furring strips.
- » Where cladding boards abutt, a 1-1/2" x 3-1/2" furring strip must be used.
- » Always ensure cladding boards are level or plumb for horizontal or vertical applications.

1-1/2" x 1-1/2"
furring strip

1-1/2" x 3-1/2"
furring strip

Install code-approved
water-resistant barrier
as required, before
installing furring strips

Maintain a minimum of
6" of clearance off grade

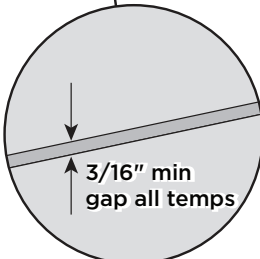
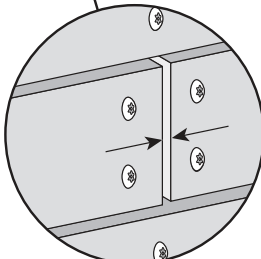
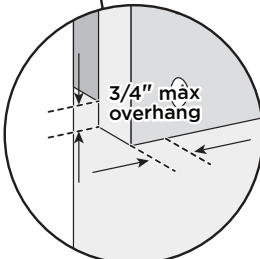
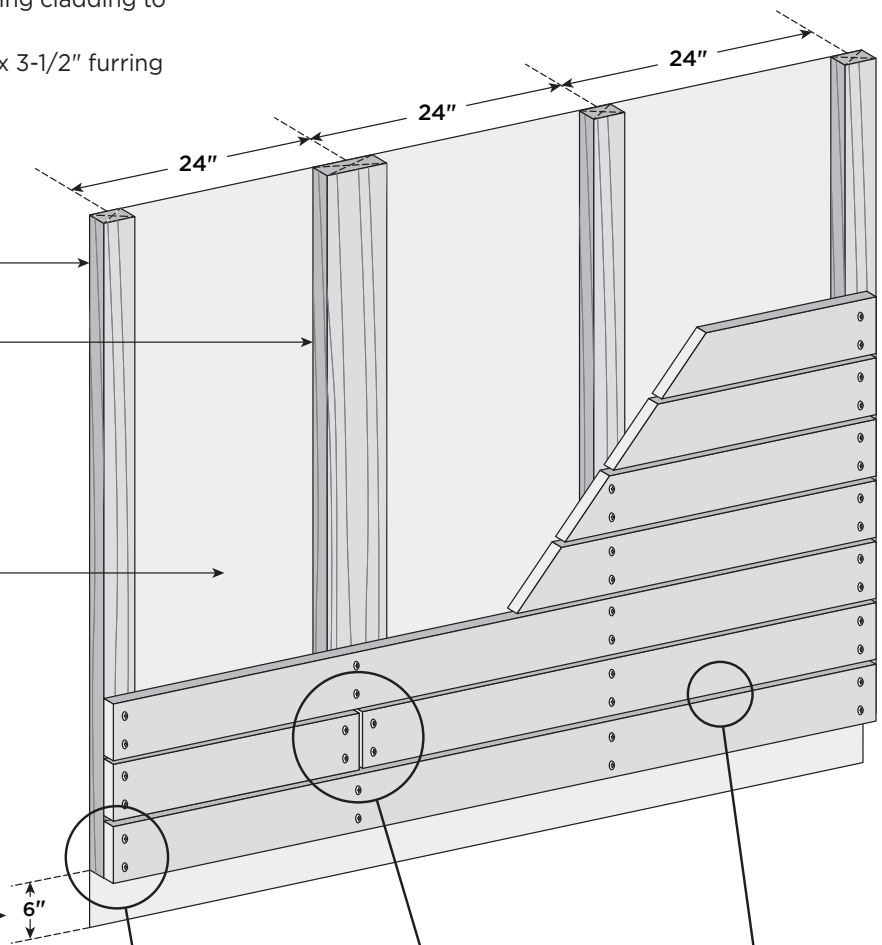

See Page 214 for Gapping Requirements

NOTE: Construction methods are always improving. Please refer to www.trex.com for the most up-to-date installation requirements.

HOW TO INSTALL OPEN-JOINT CLADDING/CONTINUED

TREX TRANSCEND®

METAL FURRING STRIPS (Not Sold by TREX)

NOTE: 18 ga. (min) 33 ksi at sizes shown below.

Z Furring Strip

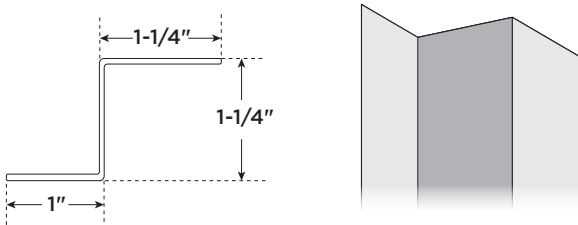

Hat Channel Furring Strip

Used for butt joint applications

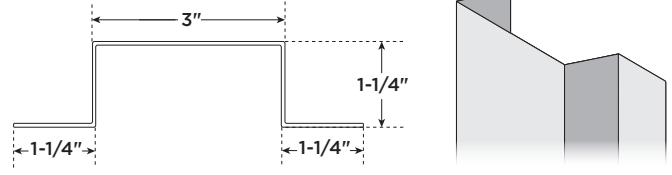

- » Install furring strips at a maximum of 24" on center.
- » Use two approved fasteners for attaching cladding to furring strips.
- » Where cladding boards abutt, provide a minimum attachment surface area of 3".
- » Always ensure cladding boards are level.

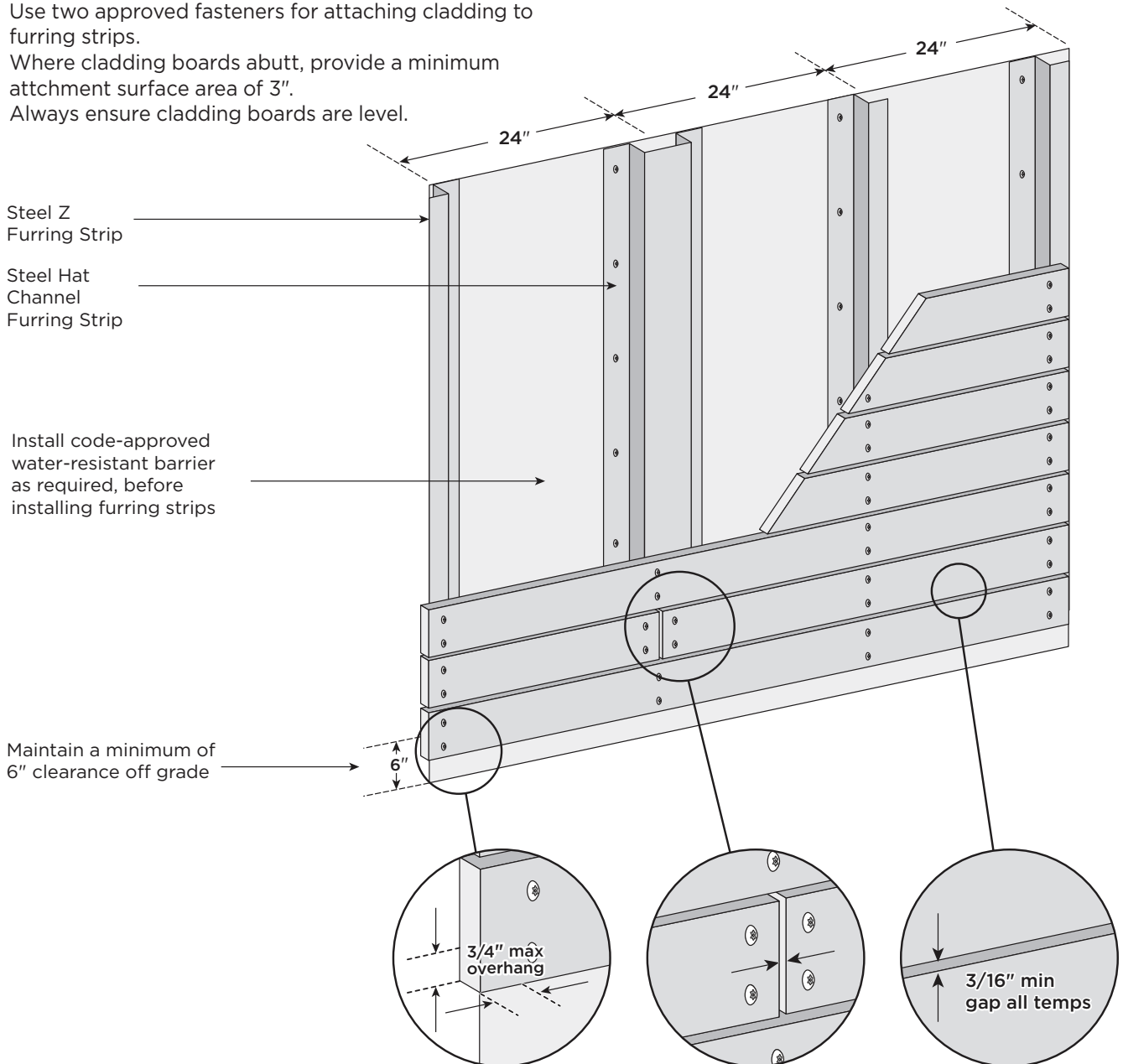

See Page 214 for Gapping Requirements

HOW TO INSTALL OPEN-JOINT CLADDING/CONTINUED

TREX TRANSCEND[®]

VERTICAL ORIENTATION OF CLADDING

(Wood furring strips represented below.)

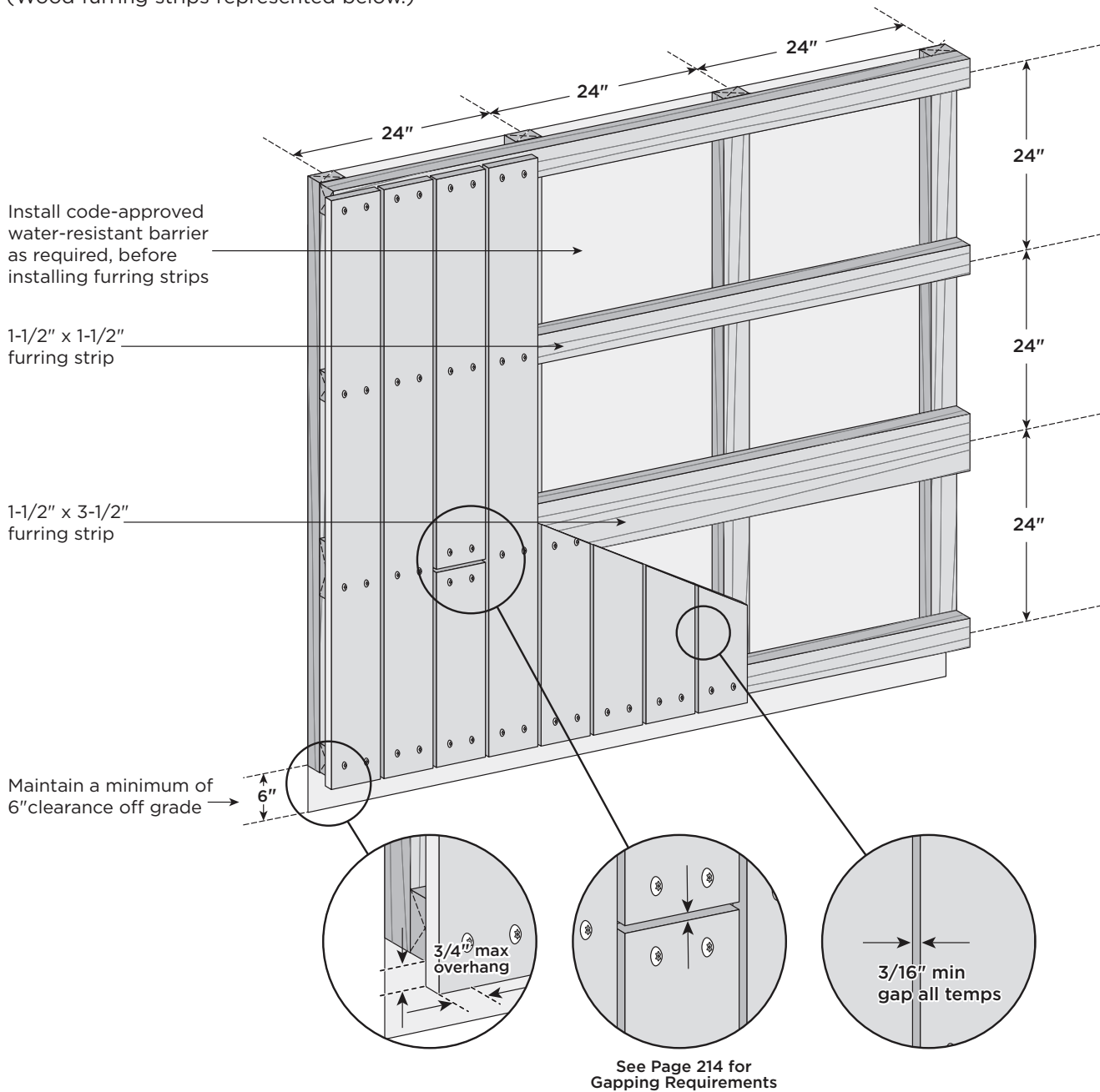

- » Install furring strips at a maximum of 24" on center.
- » Use two approved fasteners for attaching cladding to furring strips.
- » Where cladding boards abutt, a 1-1/2" x 3-1/2" furring strip must be used.
- » Always ensure cladding boards are plumb.

NOTE: Construction methods are always improving. Please refer to www.trex.com for the most up-to-date installation requirements.

WARRANTIES



TREX TRANSCEND®, TREX ENHANCE®, TREX SELECT® AND TREX® UNIVERSAL FASCIA LIMITED FADE & STAIN WARRANTY

For the term set forth below, Trex Company, Inc. (hereinafter "Trex") warrants to the original end-user purchaser (the "Purchaser") that Trex Transcend® decking, porch or fascia, Trex Enhance® decking or fascia, Trex Select® decking or fascia or Trex Universal Fascia, as the case may be (the "Product") will perform, under normal use and service conditions, as follows:

Term of Warranty: The term of this warranty shall begin on the date of original purchase, and shall end (1) twenty-five (25) years thereafter for a residential application of the Product, and (2) ten (10) years thereafter for a commercial application of the Product. Notwithstanding the foregoing, the term of this warranty for Transcend Product used as outdoor cladding shall be twenty-five (25) years for both a residential application and a commercial application.

Residential/Commercial Application: For purposes of this warranty, a "residential application" shall refer to an installation of the Product on an individual residence, and a "commercial application" shall refer to any installation of the Product other than on an individual residence.

Fade Resistance: The Product shall not fade in color from light and weathering exposure as measured by color change of more than 5 Delta E (CIE) units.

The Product is designed to resist fading. No material is fade proof when exposed to years of UV exposure and the elements. The Product is designed to resist fading, and will not in any event fade by more than 5 Delta E (CIE) units.

Stain Resistance: The Product shall be resistant to permanent staining resulting from spills of food and beverage items including ketchup, mustard, salad oils, tea, wine, coffee, fruit punch, barbeque sauce, grease, sodas and other food and beverage related items that would typically be present on a residential deck, or mold and mildew naturally occurring in the environment, provided that such substances are removed from the Product with soap and water or mild household cleaners within one (1) week of exposure of the food or beverage to the surface or first appearance of the mold and mildew.

Notwithstanding the foregoing, Trex does not warrant that the Product is stain-proof, and does not warrant stain resistance resulting from spilled or otherwise applied food and beverage substances which are not properly cleaned as provided above within one (1) week of exposure. In addition, materials not covered in the stain resistant warranty include abrasive compounds of acidic or basic pH, paints or stains, strong solvents, metallic rust or other abnormal deck use items, and non-food and non-beverage substances, including but not limited to, biocides, fungicides, plant food, or bactericides. Mold and mildew can settle and grow on any outdoor surface, including this Product. You should periodically

clean your deck to remove dirt and pollen that can feed mold and mildew. This warranty does not cover mold and mildew which is not properly cleaned as provided above within one (1) week of first appearance.

Standard Trex Company Limited Warranty: This warranty is in addition to the standard Trex Company Limited Warranty that applies to all Trex products.

Transferability: With respect to a residential application, this warranty may be transferred one (1) time, within the five (5) year period beginning from the date of original purchase by the Purchaser, to a subsequent buyer of the property upon which the Trex products were originally installed. With respect to a commercial application, this warranty is freely transferable to subsequent buyers of the property upon which the Trex products were originally installed.

EXCLUSIONS FROM WARRANTY COVERAGE:

Exposure to Heat: Direct or indirect contact with extreme heat sources (over 275 degrees) may cause fading and may damage the surface of the Product, and any effects of such exposure are expressly excluded from coverage under this warranty.

Surface Damage: Never use metal shovels or sharp-edged tools to remove snow and ice on the surface of the Product. If the surface of the Product is damaged or punctured, this warranty will be voided.

Paint or Other Materials Applied to the Product: If paint or other coating materials are applied to the Product, this warranty will be voided.

Railing: This warranty does not cover Trex Transcend®, Trex Enhance® or Trex Select® railing components.

Other Exclusions: This warranty shall not cover any condition attributable to: (1) improper installation of the Product and/or failure to abide by Trex's installation guidelines, including but not limited to improper gapping; (2) use of the Product beyond normal use or service conditions, or in an application not recommended by Trex's guidelines and local building codes; (3) movement, distortion, collapse or settling of the ground or the supporting structure on which the Product is installed; (4) any act of God (such as flooding, hurricane, earthquake, lightning, etc.); (5) improper handling, storage, abuse or neglect of the Product by Purchaser, the transferee or third parties; (6) any fading or staining not on the walking surface of the Product (i.e., the underside or the ends of the Product); or (7) ordinary wear and tear.

Procedure for Making a Claim under this Warranty

In order to make a claim under this warranty, Purchaser must do the following:

NOTE: Construction methods are always improving. Please refer to www.trex.com for the most up-to-date installation requirements.



TREX TRANSCEND®, TREX ENHANCE®, TREX SELECT® AND TREX® UNIVERSAL FASCIA LIMITED FADE & STAIN WARRANTY/continued

1. If the Purchaser is making a claim relating to the warranty on stain resistance, Purchaser must do as follows:

(a) Purchaser must try to clean the affected area of the deck by using the cleaning procedures described above within one (1) week of exposure of the food or beverage to the Product or first appearance of the mold and mildew.

(b) If the affected area remains reasonably unsatisfactory after Purchaser has tried these cleaning procedures, then Purchaser must have the affected area of the deck professionally cleaned at Purchaser's expense.

(c) If the affected area remains reasonably unsatisfactory after the professional cleaning, Purchaser may make a claim under this warranty, provided that such claim is made within thirty (30) days after the professional cleaning.

2. To make a claim under this limited warranty, Purchaser, or the transferee, shall send to Trex, within the warranty period referred to above, a description and photographs of the affected area of the Product, proof of purchase, and if the claim relates to the warranty on stain resistance, proof of compliance with paragraph 1. above, to the following address:

Trex Company, Inc.
Customer Relations
160 Exeter Drive
Winchester, VA 22603-8605

3. Upon confirmation by an authorized Trex representative of a valid claim hereunder, Trex's sole responsibility shall be, at its option, to either replace the affected item or refund the portion of the purchase price paid by Purchaser for such affected item (not including the cost of its initial installation). Replacement material will be provided that is as close as possible in color, design and quality as the replaced material, but Trex does not guarantee an exact match as colors and design may change.

4. If a valid warranty claim hereunder is made during years eleven (11) through twenty-five (25) after the original purchase for a residential application, recovery will be prorated. If Trex is providing replacement materials, it may elect to replace the percentage listed below of boards otherwise meeting the requirements for a claim, or if it is refunding the purchase price, it may elect to refund the percentage listed below of the purchase price of boards otherwise meeting the requirements for a claim.

YEAR OF WARRANTY CLAIM	PERCENTAGE RECOVERY
11	80%
12	80%
13	80%
14	60%
15	60%
16	60%
17	40%
18	40%
19	40%
20	20%
21	20%
22	20%
23	10%
24	10%
25	10%

5. TO THE FULLEST EXTENT PERMITTED UNDER THE LAW, THIS WARRANTY SHALL NOT COVER AND TREX SHALL NOT BE RESPONSIBLE FOR COSTS AND EXPENSES INCURRED WITH RESPECT TO THE REMOVAL OF AFFECTED PRODUCT OR THE INSTALLATION OF REPLACEMENT MATERIALS, INCLUDING BUT NOT LIMITED TO LABOR AND FREIGHT.

No person or entity is authorized by Trex to make and Trex shall not be bound by any statement or representation as to the quality or performance of Trex products other than as contained in this warranty. This warranty may not be altered or amended except in a written instrument signed by Trex and Purchaser.

TO THE FULLEST EXTENT PERMITTED UNDER THE LAW, UNDER NO CIRCUMSTANCES WILL TREX BE LIABLE FOR INCIDENTAL OR CONSEQUENTIAL DAMAGES, WHETHER SUCH DAMAGES ARE SOUGHT IN CONTRACT, IN TORT (INCLUDING BUT NOT LIMITED TO NEGLIGENCE AND STRICT LIABILITY) OR OTHERWISE, AND TREX'S LIABILITY FOR NON-PERSONAL INJURY CLAIMS WITH RESPECT TO PRODUCTS SHALL IN NO EVENT EXCEED THE REPLACEMENT OF SUCH PRODUCTS OR REFUND OF THE PURCHASE PRICE, AS DESCRIBED ABOVE.

Some States or Provinces do not allow the exclusion or limitation of incidental or consequential damages, so the above limitation or exclusion may not apply to you. This warranty gives you specific legal rights, and you may also have other rights that vary from State to State or Province to Province.

Copyright © 2021 Trex Company, Inc.



TREX® LIMITED WARRANTY

Trex Company, Inc. (hereinafter "Trex") warrants to the original purchaser ("Purchaser") that, for the period of time set forth in the following sentence, under normal use and service conditions, Trex® product (the "Product") shall be free from material defects in workmanship and materials, and shall not split, splinter, rot or suffer structural damage from termites or fungal decay. The term of such warranty shall be twenty-five (25) years from the date of original purchase for a residential application, and ten (10) years from the date of original purchase for a commercial application. If a defect occurs within the warranty period, Purchaser shall notify Trex in writing and, upon confirmation by an authorized Trex representative of the defect, Trex's sole responsibility shall be, at its option, to either replace the defective Product or refund the portion of the purchase price paid by Purchaser for such defective Product (not including the cost of its initial installation).

For purposes of this warranty, a "residential application" shall refer to an installation of the Product on an individual residence, and a "commercial application" shall refer to any installation of the Product other than on an individual residence.

Notwithstanding the foregoing, (a) the term of the warranty for the LED lights and housing for Trex DeckLighting™ shall be seven (7) years, the term of the warranty for the LED lights and housing for Trex LandscapeLighting™ shall be five (5) years, the term of the warranty for the dimmer, timer and transformer for both shall be three (3) years, and the term of the warranty for the motion controller for both shall be one (1) year, in each case provided that a Trex transformer is used (with no warranty on any components if a Trex transformer is not used), and any other parts or accessories shall not be warranted; (b) with respect to hardware for the Trex Surroundings® gate (gate frame, hinges and screws), the term of the warranty shall be five (5) years, (c) with respect to Trex Decorative Balusters, the term of the warranty covering the paint coating shall be ten (10) years, and shall be prorated in the following manner: 100% replacement for the first five (5) years; and 50% replacement for the next five (5) years, (d) the term of the warranty for Transcend Product used as outdoor cladding shall be twenty-five (25) years for both a residential application and a commercial application, and (e) this warranty shall not apply to Trex Elevations® steel deck framing, Trex Signature® aluminum railing and TrexTrim™ (which each have separate warranties).

TO THE FULLEST EXTENT PERMITTED UNDER THE LAW, THIS WARRANTY SHALL NOT COVER AND TREX SHALL NOT BE RESPONSIBLE FOR COSTS AND EXPENSES INCURRED WITH RESPECT TO THE REMOVAL OF DEFECTIVE PRODUCT OR THE INSTALLATION OF REPLACEMENT MATERIALS, INCLUDING BUT NOT LIMITED TO LABOR AND FREIGHT.

With respect to a residential application, this warranty may be transferred one (1) time, within the five (5) year period beginning from the date of original purchase by the Purchaser, to a subsequent buyer of the property upon which the Product was originally installed. With respect to a commercial application, this warranty

is freely transferable to subsequent buyers of the property upon which the Product was originally installed.

To make a claim under this limited warranty, Purchaser, or the transferee, shall send to Trex, within the warranty period referred to above, a description of the claimed defect and proof of purchase, to the following address:

Trex Company, Inc.
Customer Relations
160 Exeter Drive
Winchester, VA 22603-8605

Trex does not warrant against and is not responsible for any condition attributable to: (1) improper installation of Product and/or failure to abide by Trex's installation guidelines, including but not limited to improper gapping; (2) use of Product beyond normal use and service conditions, or in an application not recommended by Trex's guidelines and local building codes; (3) movement, distortion, collapse or settling of the ground or the supporting structure on which Product is installed; (4) any act of God (such as flooding, hurricane, earthquake, lightning, etc.), environmental condition (such as air pollution, mold, mildew, etc.), staining from foreign substances (such as dirt, grease, oil, etc.), or normal weathering (defined as exposure to sunlight, weather and atmosphere which will cause any colored surface to gradually fade, chalk, or accumulate dirt or stains); (5) variations or changes in color of Product; (6) improper handling, storage, abuse or neglect of Product by Purchaser, the transferee or third parties; or (7) ordinary wear and tear.

No person or entity is authorized by Trex to make and Trex shall not be bound by any statement or representation as to the quality or performance of Product other than as contained in this warranty. This warranty may not be altered or amended except in a written instrument signed by Trex and Purchaser.

TO THE FULLEST EXTENT PERMITTED UNDER THE LAW, UNDER NO CIRCUMSTANCES WILL TREX BE LIABLE FOR INCIDENTAL OR CONSEQUENTIAL DAMAGES, WHETHER SUCH DAMAGES ARE SOUGHT IN CONTRACT, IN TORT (INCLUDING BUT NOT LIMITED TO NEGLIGENCE AND STRICT LIABILITY) OR OTHERWISE, AND TREX'S LIABILITY FOR NON-PERSONAL INJURY CLAIMS WITH RESPECT TO DEFECTIVE PRODUCT SHALL IN NO EVENT EXCEED THE REPLACEMENT OF SUCH PRODUCT OR REFUND OF THE PURCHASE PRICE, AS DESCRIBED ABOVE.

Some States or Provinces do not allow the exclusion or limitation of incidental or consequential damages, so the above limitation or exclusion may not apply to you. This warranty gives you specific legal rights, and you may also have other rights that vary from State to State or Province to Province.

Copyright © 2021 Trex Company, Inc.





TREX SIGNATURE®/REVEAL® RAILING LIMITED WARRANTY

Trex Company, Inc. (hereinafter "Trex") warrants to the original purchaser ("Purchaser") that, under normal use and service conditions, Trex Signature®/Reveal® Railing (the "Product") shall, for a period of twenty-five (25) years from the date of original purchase, be free from material defects in workmanship and materials. If a defect occurs within the warranty period, Purchaser shall notify Trex in writing and, upon confirmation by an authorized Trex representative of the defect, Trex's sole responsibility shall be, at its option, to either replace the defective Product or refund the portion of the purchase price paid by Purchaser for such defective Product (not including the cost of its initial installation).

With respect to installations where the atmosphere is influenced by a body of salt water (or other contaminant conditions), failure to adhere to the cleaning guidelines available at www.trex.com will void this warranty with respect to any condition resulting from such failure.

TO THE FULLEST EXTENT PERMITTED UNDER THE LAW, THIS WARRANTY SHALL NOT COVER AND TREX SHALL NOT BE RESPONSIBLE FOR COSTS AND EXPENSES INCURRED WITH RESPECT TO THE REMOVAL OF DEFECTIVE PRODUCT OR THE INSTALLATION OF REPLACEMENT MATERIALS, INCLUDING BUT NOT LIMITED TO LABOR AND FREIGHT.

This warranty may be transferred one (1) time, within the five (5) year period beginning from the date of original purchase by the Purchaser, to a subsequent buyer of the property upon which the Product was originally installed.

To make a claim under this limited warranty, Purchaser, or the transferee, shall send to Trex, within the warranty period referred to above, a description of the claimed defect and proof of purchase, to the following address:

Trex Company, Inc.
Customer Relations
160 Exeter Drive
Winchester, VA 22603-8605

Trex does not warrant against and is not responsible for any condition attributable to: (1) improper installation of the Product; (2) use of the Product beyond normal use and service conditions, or in an application not recommended by Trex's guidelines and local building codes; (3) movement, distortion, collapse or settling of the ground or the supporting structure on which the Product is installed; (4) damages attributable to fire, violent storms, earthquake or other Acts of God, accidents, vandalism, or other casualties, impact of objects, or exposure to atmospheric pollutants or conditions other than natural weather processes, (5) improper handling, storage, abuse or neglect of the Product by Purchaser, the transferee or third parties; or (6) ordinary wear and tear.

No person or entity is authorized by Trex to make and Trex shall not be bound by any statement or representation as to the quality or performance of Trex products other than as contained in this warranty. This warranty may not be altered or amended except in a written instrument signed by Trex and Purchaser.

TO THE FULLEST EXTENT PERMITTED UNDER THE LAW, UNDER NO CIRCUMSTANCES WILL TREX BE LIABLE FOR INCIDENTAL OR CONSEQUENTIAL DAMAGES, WHETHER SUCH DAMAGES ARE SOUGHT IN CONTRACT, IN TORT (INCLUDING BUT NOT LIMITED TO NEGLIGENCE AND STRICT LIABILITY) OR OTHERWISE, AND TREX'S LIABILITY FOR NON-PERSONAL INJURY CLAIMS WITH RESPECT TO DEFECTIVE PRODUCTS SHALL IN NO EVENT EXCEED THE REPLACEMENT OF SUCH PRODUCTS OR REFUND OF THE PURCHASE PRICE, AS DESCRIBED ABOVE.

Some States or Provinces do not allow the exclusion or limitation of incidental or consequential damages, so the above limitation or exclusion may not apply to you. This warranty gives you specific legal rights, and you may also have other rights that vary from State to State or Province to Province.

Copyright © 2018 Trex Company, Inc.

DECKING COLOR PALETTE



RAILING COLOR PALETTE

ALUMINUM:

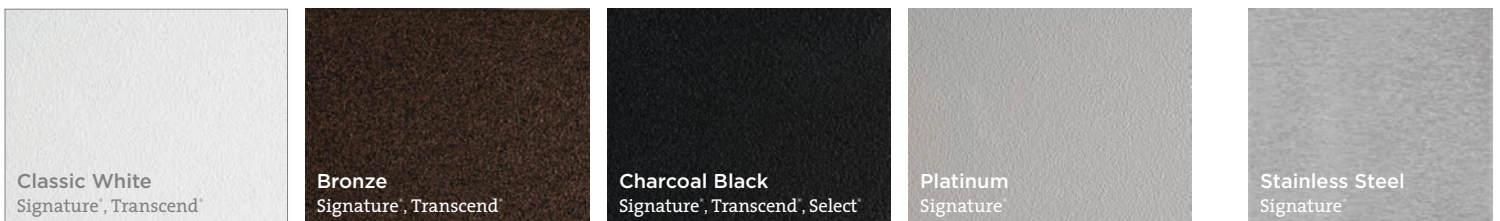

MESH:

COMPOSITE:





*front: Transcend Tropicals in Spiced Rum and Signature Mesh Railing
back: Enhance Naturals in Rocky Harbor and Select Railing*

DECKING | RAILING | LIGHTING | FASCIA | KITCHENS | FURNITURE | PERGOLA | DRAINAGE



Engineering What's Next
in Outdoor Living®

FIND US ON



Visit trex.com or call 1-800-BUY-TREX

© 2021 Trex Company, Inc. All rights reserved. Trex®, the Trex logo, TrexPro®, Trex Enhance®, Trex Select®, Trex Transcend®, Trex Signature®, Trex® Outdoor Lighting™, Trex® Fascia, Trex® Pergola™, Trex® Outdoor Kitchens™, Trex® Spiral Stairs™, Trex® RainEscape®, Trex® Protect™, Trex Hideaway® and Trex LightHub® are either federally registered trademarks, trademarks or trade dress of Trex Company, Inc., Winchester, Virginia or its licensees.